

# Team Giocondi

Politecnico di Milano  
Dipartimento di Scienze e Tecnologie Aerospaziali



## EXECUTIVE SUMMARY

**Team members:**

- Matteo DANIELE
- Alessandro COCCO
- Pierre GARBO
- Davide MARIANI
- Edoardo SASSI

**Faculty advisor:**

Prof. Giuseppe QUARANTA

# Signature page

- **Matteo Daniele**, graduate, [matteo.daniele@polimi.it](mailto:matteo.daniele@polimi.it)

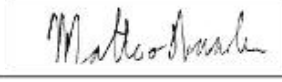
Signature  \_\_\_\_\_

- **Alessandro Cocco**, graduate, [alessandro.cocco@polimi.it](mailto:alessandro.cocco@polimi.it)

Signature  \_\_\_\_\_

- **Pierre Garbo**, graduate, [pierre.garbo@polimi.it](mailto:pierre.garbo@polimi.it)

Signature  \_\_\_\_\_

- **Davide Mariani**, graduate, [davide10.mariani@mail.polimi.it](mailto:davide10.mariani@mail.polimi.it)

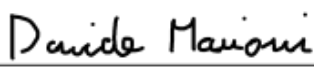
Signature  \_\_\_\_\_

- **Edoardo Sassi**, graduate, [edoardo1.sassi@mail.polimi.it](mailto:edoardo1.sassi@mail.polimi.it)

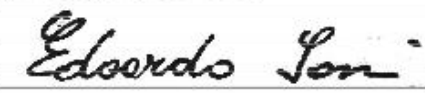
Signature  \_\_\_\_\_

Faculty Advisor:

- **Giuseppe Quaranta**, Full Professor, [giuseppe.quaranta@polimi.it](mailto:giuseppe.quaranta@polimi.it)

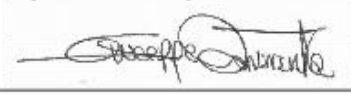
Signature  \_\_\_\_\_

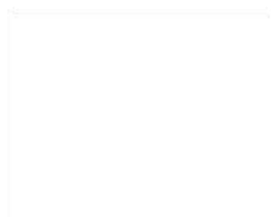

# Team Giocondi

Giocondi team is composed of 5 members:



**Alessandro Cocco**

Aeronautical engineer and PhD student at Aerospace science and Technology department (DAER) at Politecnico di Milano



**Matteo Daniele**

Aeronautical engineer and PhD student at Aerospace science and Technology department (DAER) at Politecnico di Milano



**Pierre Garbo**

Space engineer and PhD student at Aerospace science and Technology department (DAER) at Politecnico di Milano



**Davide Mariani**

Aerospace engineer and Aeronautical engineering student at Politecnico di Milano



**Edoardo Sassi**

Aerospace engineer and Aeronautical engineering student at Politecnico di Milano

# Introduction

Leonardo Da Vinci's ideas and intuitions have fascinated generations of engineers and aspiring inventors. The observation and study of nature brought him to develop a plethora of projects and designs that were well ahead of his time, speaking of which, the aerial screw is one of the most interesting examples.

The working principle of the aerial screw is in some way the anticipation of the theory under the modern aircraft propeller, but unfortunately remains a theoretical design with small if not null possible applications in the aerospace field. In the following work, we have implemented our version of the aerial screw, trying (humbly) to solve the practical limitations of Leonardo's intuitions.

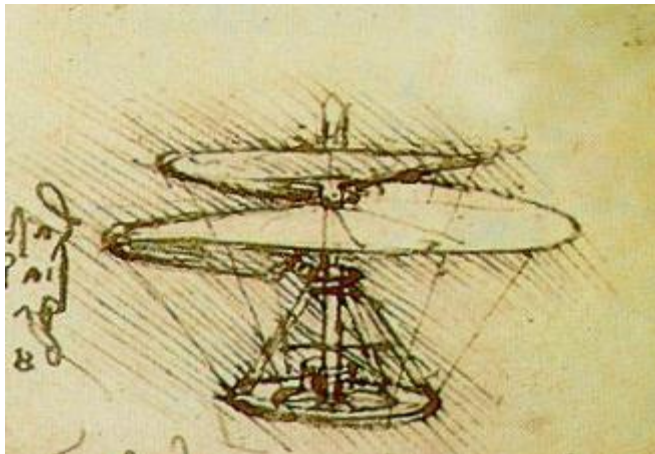

*Leonardo's areal screw from Codex Atlanticus*

The result of the design process is an aircraft named STOAT which is the acronym of Short TakeOff with Azimuth Thrusters but at the same time is also a tribute to the famous Leonardo Da Vinci's work of art, the Lady with an Ermine

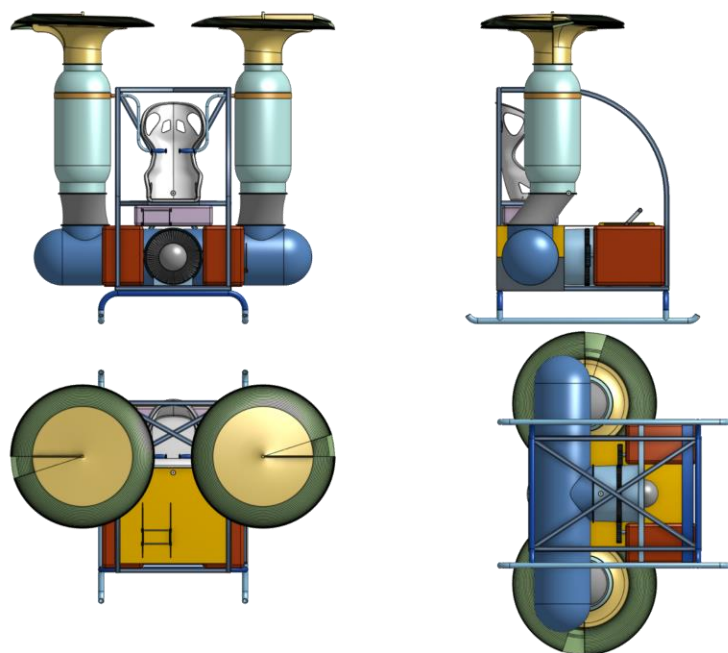
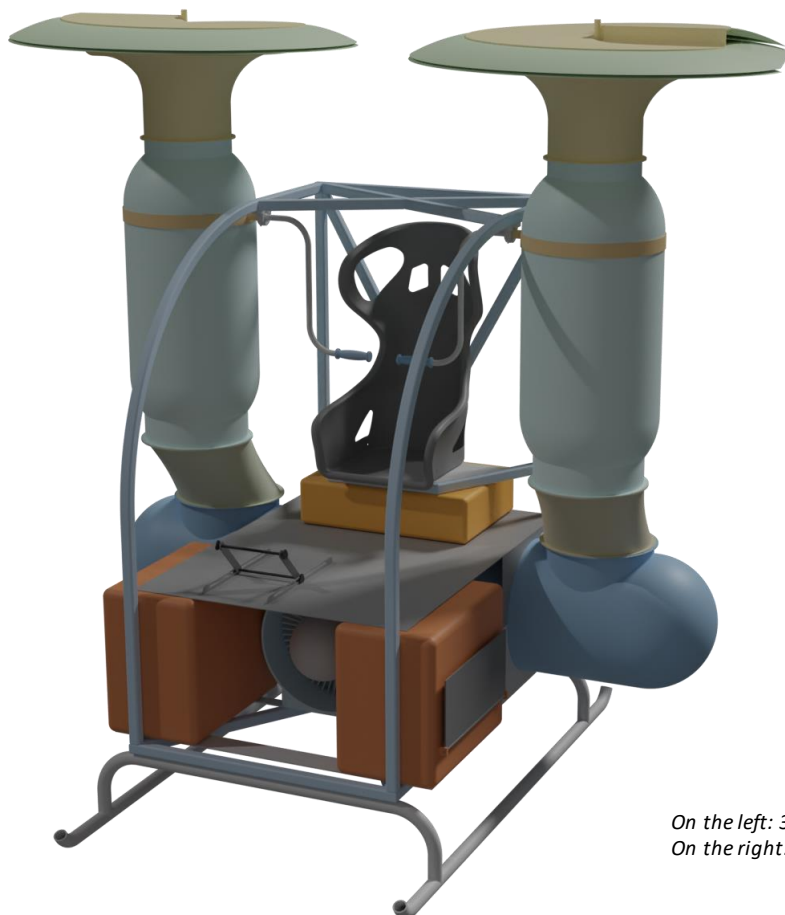

*On the left: 3D view of STOAT.  
On the right: front, lateral, top and bottom views.*

# Working principle implementation

**Idea:** airflow blown on a fixed aerodynamic surface to produce the required lift by keeping the solidity of the lifting surface greater than 1.

## Main advantages:

- no need to spin the lifting body: spiral shape can be optimized to have a higher aerodynamic efficiency;
- the structure can be easier and stiffer if compared to the original design

## Main disadvantages:

- The flow must be oriented in the proper way towards the leading edge of the lifting body;
- Airflow must have enough speed to be able to produce lift

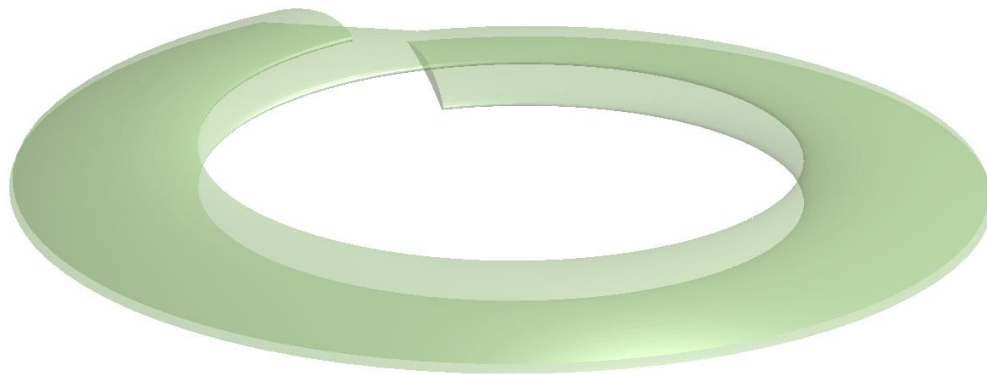

- The aerial screw lifting surface can be considered as an airfoil swept along a spiral, with the leading edge facing the center of the spiral and the trailing edge facing outward.
- There are no limitations to the number of turns of the spiral and to the angle of attack of the airfoil.
- The central cylindrical slot is the source of the quasi-radial airflow that will hit the leading edge of the aerial screw.
- The structure is static, it is convenient to orient the airflow in order to have the maximum lift condition on the airfoil.
- This will lead to the airflow going radially outward, following the spiral path.
- To achieve such a radial flow, a nozzle is used, that collect the necessary air flow from below and change its direction to orient it radially towards the airfoil.

# Overall design

- Compact size;
- Light weight;
- High stability;
- Large field of view;
- Easy and quick get on and get off procedure;
- Tilttable nacelles to orient thrust, controlled by pilot through handlebars;
- Pedal to control altitude setpoint;
- Throttle-like knobs to control lateral speed for turning;
- Compressor and pneumatic system to produce airflow;
- Electric power unit: Lithium batteries;
- Automatic control system to provide stabilization and control enhancement.

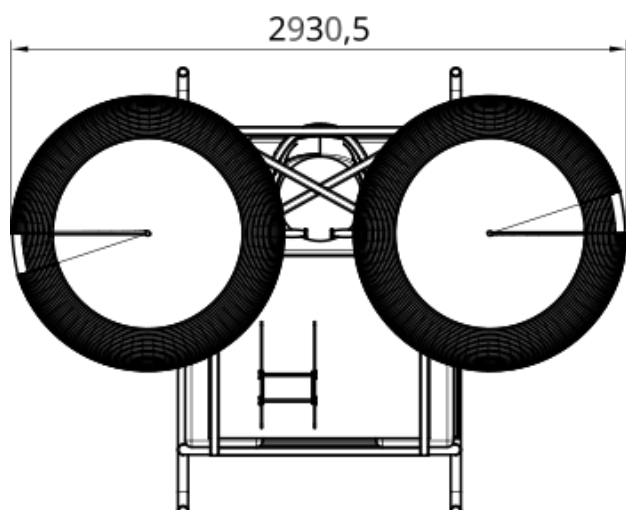
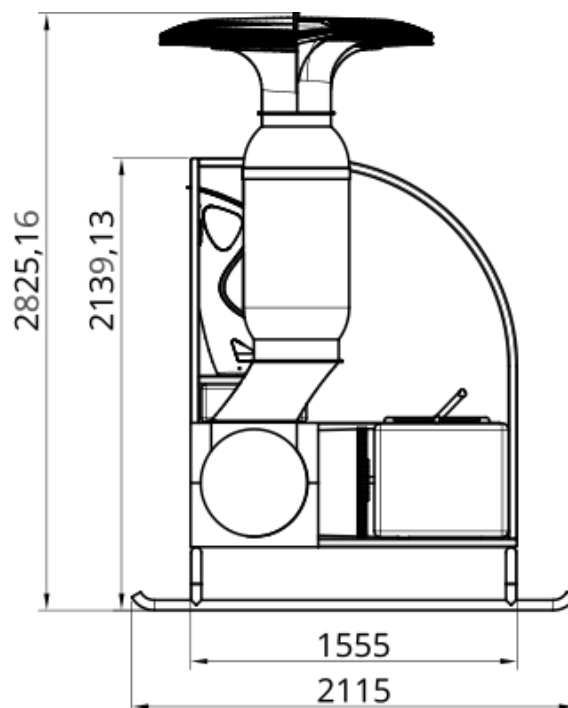
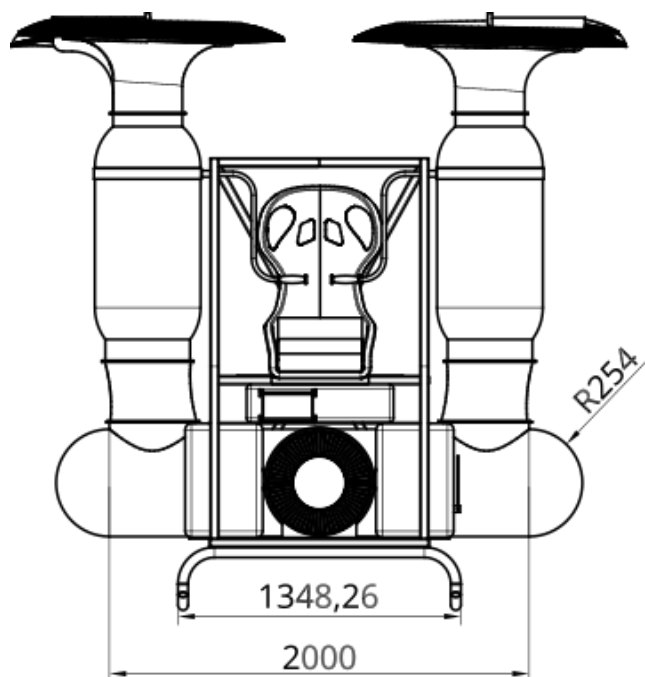

# Subsystems – Power Unit

The objective of the power unit system is to store the energy in batteries for the flight mission and transform into mechanical energy for the compressor.

The power unit consists on one battery pack and two AC motors: it has been considered the components used in the Energica Corsa motorbike.

Weights and dimensions of each subcomponent have not been officially declared by the manufacturer so, based on the actual size and weight of the motorbike, an estimate has been done.



Energica Corsa

	Battery pack	AC motor
Dimensions (L-W-H) (mm)	500-700-180	640-370-540
Weight (kg)	33.4	39.6

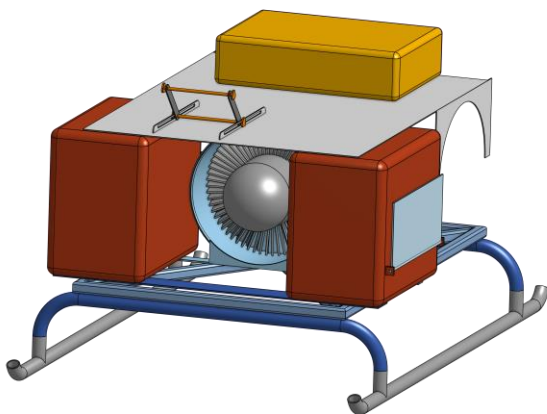

CAD rendering of the power unit installed: red boxes represents the sizes of the AC motors while the element in yellow is the battery pack.

## Key features:

- **High performance:** the power unit assembly has been designed for the highest level of competition;
- **Safety:** the battery pack is sealed and mechanical strength and impact resistance tests have been conducted by the manufacturer.

- **Reduced dimensions and weight:** since the assembly is installed in a competition motorbike, every centimetre and gram matter.

Performance of the power unit, according to the manufacturer are:

- **Battery:** Lithium Ion cells with 20 kWh of energy;
- **AC motor:** 120 kW of power, 215 Nm of torque from 0 to 5000 RPM.

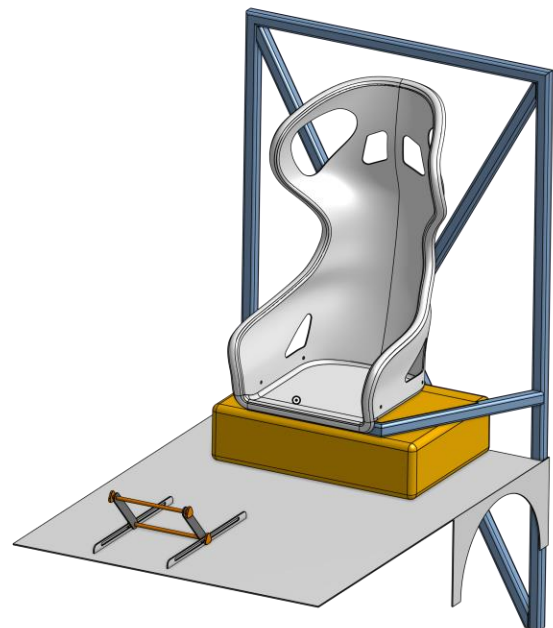

CAD rendering of the battery pack and pilot seat

# Subsystems – Pneumatic system

The objective of the pneumatic system is to feed the propulsion system with the air pressurized by the compressor with the right velocity and provide a form of control along the vertical axis of the aircraft.

- A schematic of the pneumatic system is depicted below:

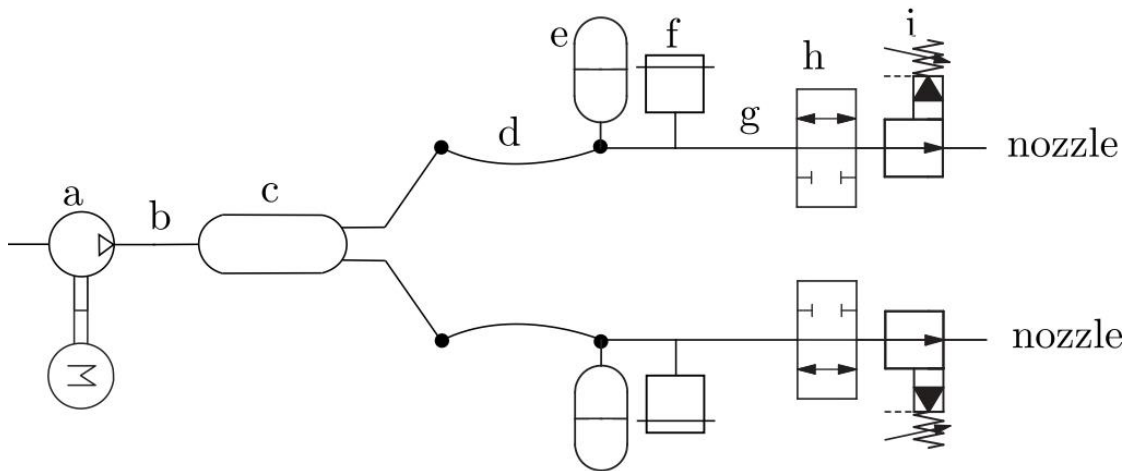

- a) Compressor;
- b) Rigid pipe;
- c) Air reservoir;
- d) Flexible pipe;
- e) Accumulator;
- f) Safety valve;
- g) Rigid pipe;
- h) Gate Valve;
- i) Flow control valve

Location	Pressure (bar)	Airflow (m <sup>3</sup> )	Aispeed (m/s)
Compressor	1.4	11	66.2
Nozzle	1.38	5.5	65



Accumulator and nozzle

## Key features:

- Safety:** safety valves opens automatically when the pressure inside the system doubles the nominal pressure.
- High performance:** through appropriate materials of pipes and geometry of junctions, pressure loss in the system due to friction is minimized.
- Intuitive control:** takeoff, hover and landing maneuvers can be done acting on the pedal which varies the area of the flow control valve orifice. reduces the air flow to the propulsion system and by consequence, the vertical speed of the aircraft.

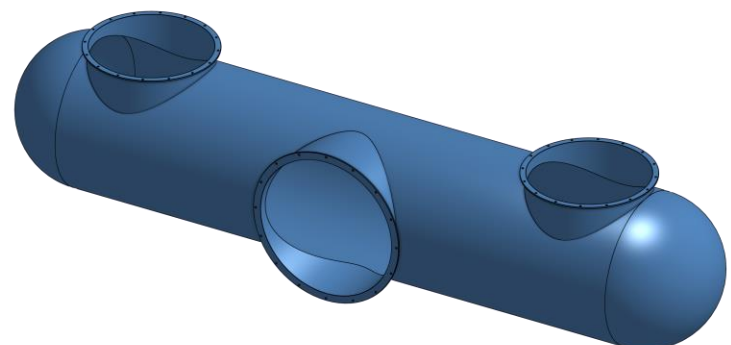

Air reservoir

# Subsystems – Frame and structure

Structure designed to minimize as much as possible the overall weight of the flying machine. All the components have been designed to ensure compactness and ease of assembly.

- Main frame composed of a structure of standard square tubes made of aluminum 7075 TIG welded together,
- aluminum skid landing gear to further increase weight efficiency and allow stability on ground.
- Roller bearings mounted on the upper part of the frame, which are the pivot point of the nacelles.
- The pilot seats in a elevated position, on the upper side of the flying machine.
- Altitude is controlled by pressing or releasing the pedal in front.
- The handles are used to tilt the nacelles and achieve forward speed by orienting the thrust.
- Frame, design inspired by Leonardo's "Codex Atlanticus" drawings

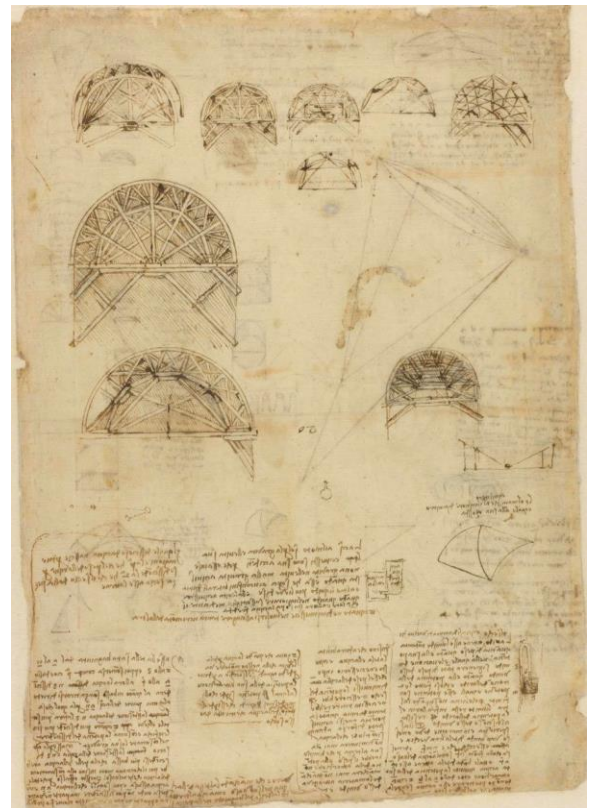
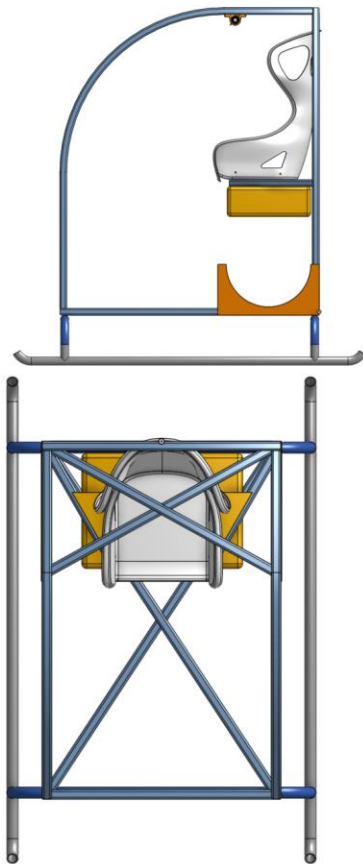
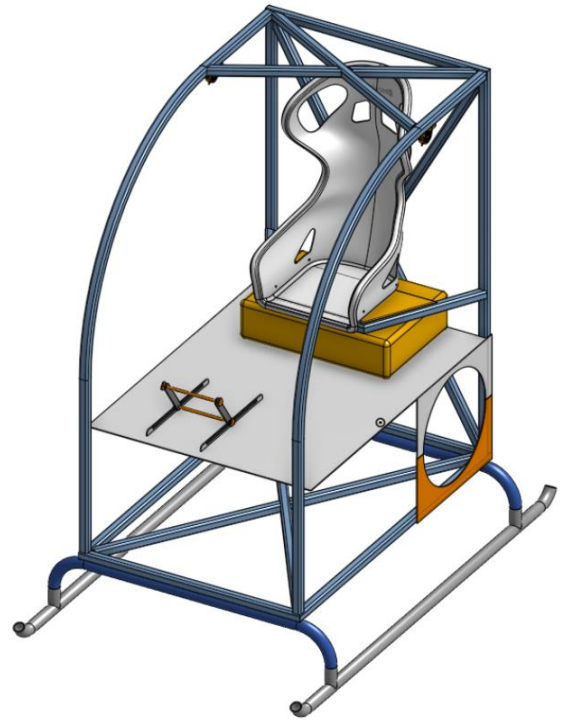

# Subsystems – Propulsion system

To generate the required lift, the aerial screw designed by Leonardo da Vinci is revisited: the spiral is enlarged in order to locate the air flow source at the center of it.

- The nozzle, visible in yellow in the section view, collect the air flow from below and redirect it radially toward the aerial screw.
- The aerial screw is represented by a spiral airfoil with solidity 1.95

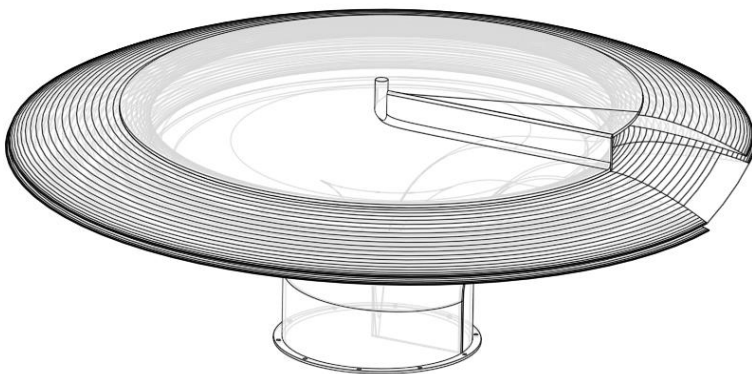
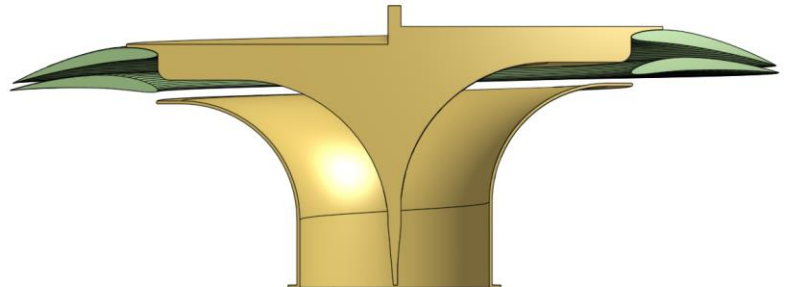

- Radial elements are inserted in the aerial screw to increase the stiffness of the structure and help keeping the airfoil in the desired orientation.
- The radial elements are also needed to help keeping the air flow laminar as it moves radially outward

- The first turn of the aerial screw is set to an angle of attack such that the maximum lift is reached.
- The second turn of the aerial screw has an angle of attack that create, together with the first turn, a convergent nozzle on the low pressure side of the first turn, in order to further decrease the pressure and increase the lift

### Aerial screw lifting body properties

number of screws	2
Solidity	1.95
Screw pitch	0.025
nozzle diameter [m]	0.8 m
MTOW [kg]	400 kg
Total mass flow rate [kg/s]	11.689
Airfoil type	NACA 6409
Chord [m]	0.25
AoA [deg]	10
Surface [m <sup>2</sup> ]	0.824668072
Lift (hover OGE) [N]	2158.2
Air velocity at nozzle [m/s]	51.6765148
$C_l$ (AoA = 10 deg)	1.6

The propulsive unit is fixed to the last part of the pneumatic system and the control happens in two ways:

- By tilting it, to move forward, backward and to yaw;
- By changing the air flow rate to control the vertical motion.

# Subsystems – Compressor

The compressor was designed from scratch in order to provide the required air flow rate of 11.68 m<sup>3</sup>/s

Front radius	0.2757
Front area	0.238793997
Back radius	0.264150629
Back area	0.219206371
Total length	0.456426478
Mass	30

Number of stages	3
Hub/tip ratio	0.5
Tip radius in	0.25
Root radius in	0.125
Tip radius out	0.238450629
Root radius out	0.136549371
Mean radius	0.1875
Tip gap	0.0007
Axial gap	0.005

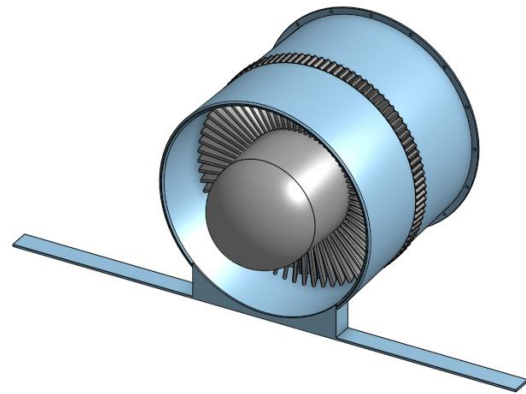

- 3 stages compressor with dedicated design of each stage's blades.
- Cascade analysis to compute the number of blades for rotor and stator of each stage

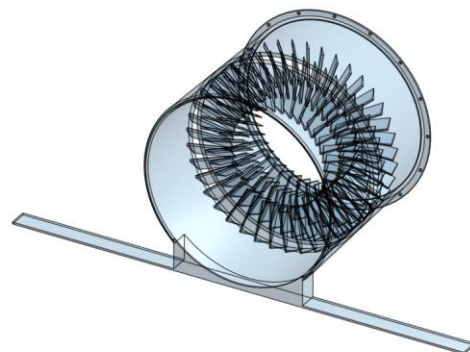
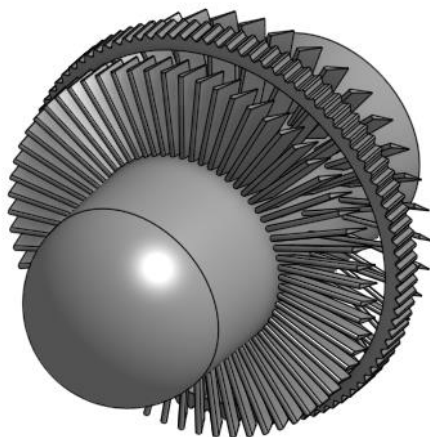

- Geared wheel added to the central rotor to engage the motors shafts: the rotational motion is given without interfering with the air flow;
- The stator case is splitted to allow the motors to spin the rotor;
- The front part of the compressor is fixed to the frame, the rear is fixed to the beginning of the pneumatic system

# Performance evaluation

STOAT has been modeled using a multidisciplinary approach

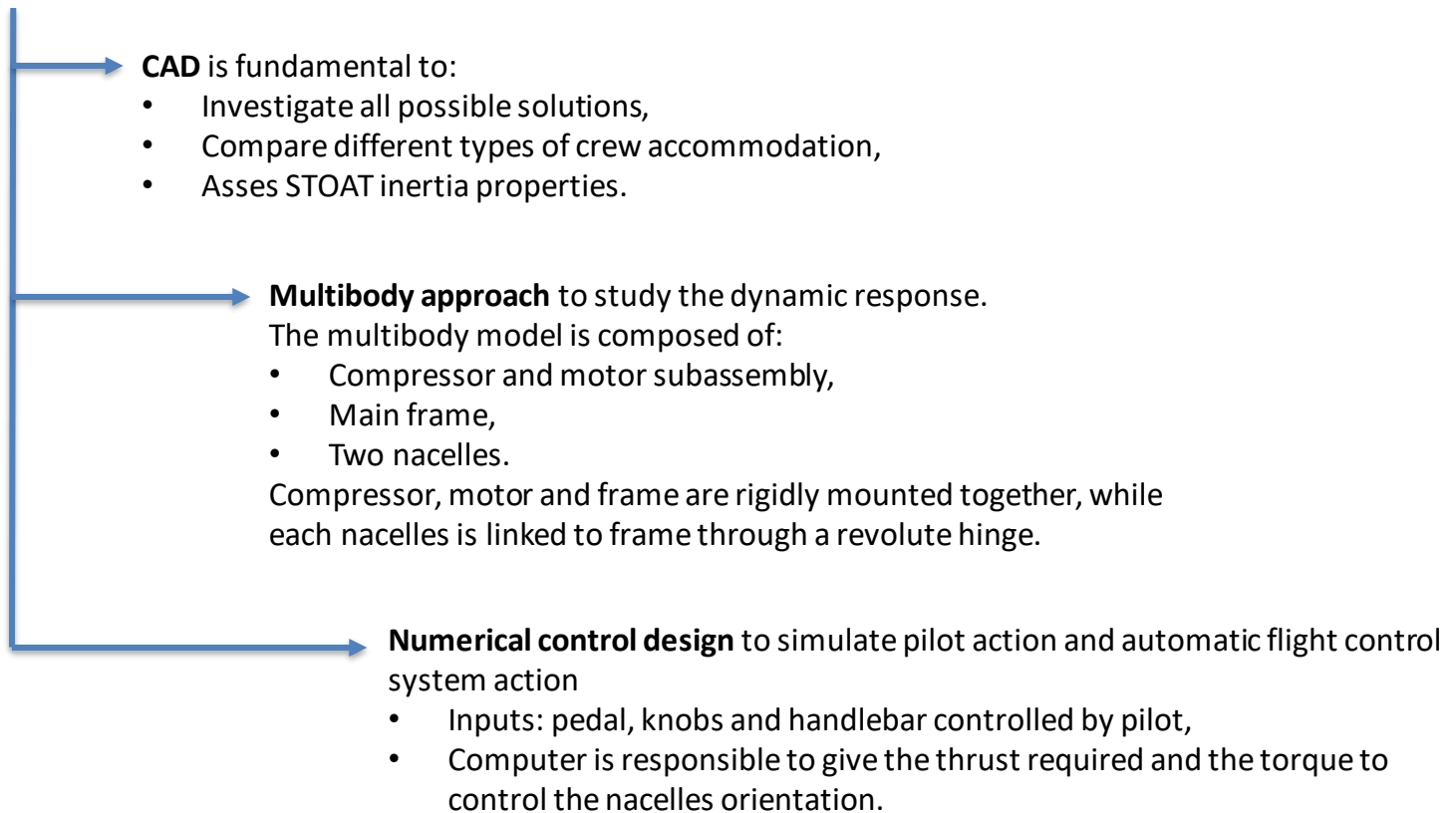

About the **numerical simulation** the following simplification hypothesis are taken into account:

- Aerodynamic drag represented by a linear damping coefficient on 6 degrees of freedom,
- Compressor rotor, electric motor and transmission are not rotating during the simulation.

Some noticeable results are reported in the following time histories:

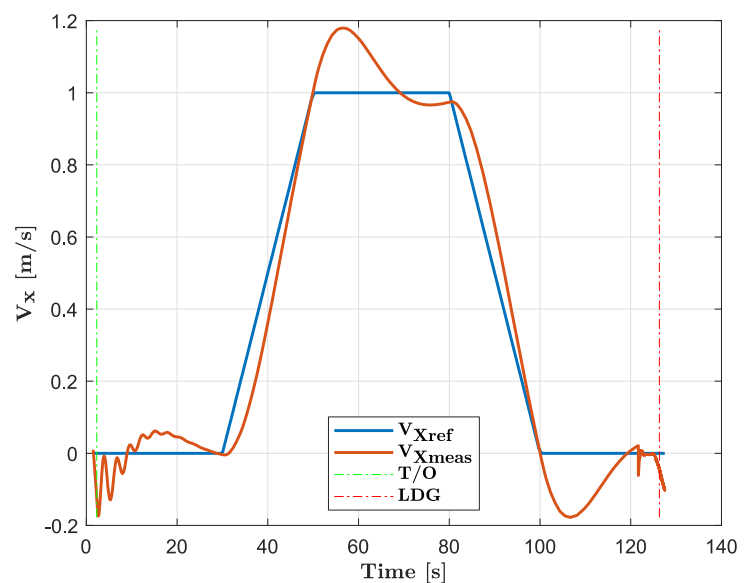
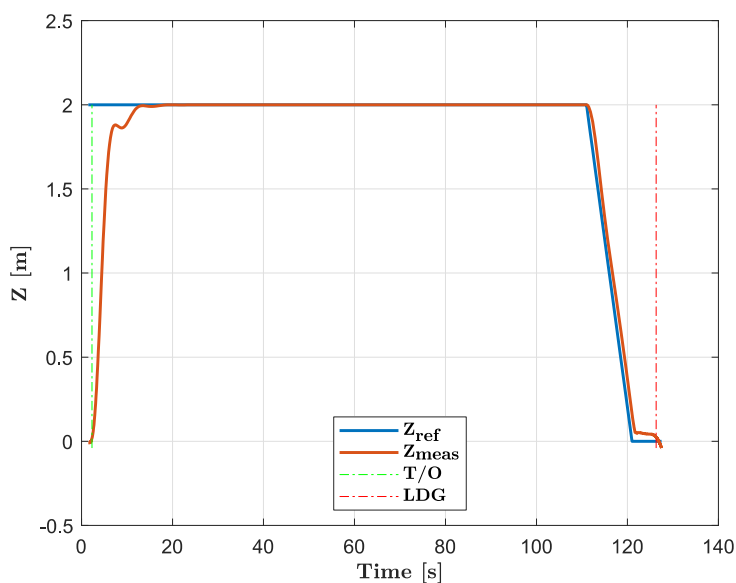

# Performance evaluation

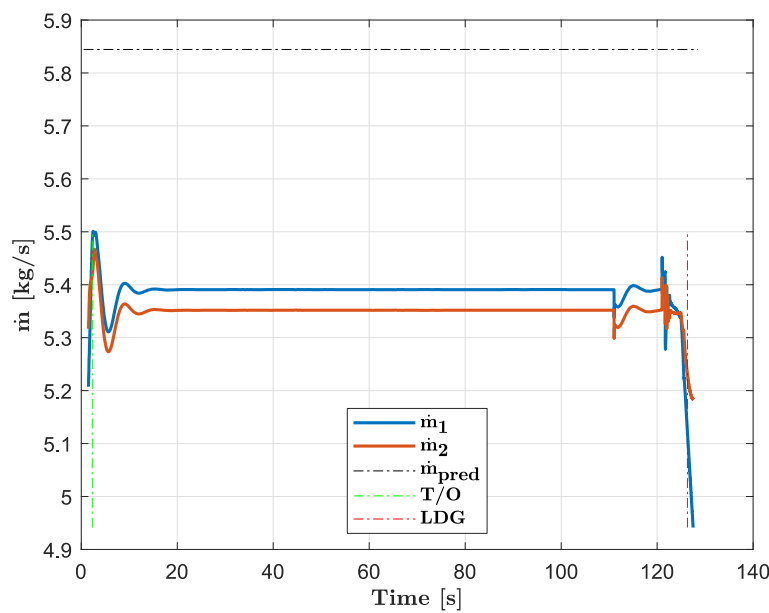
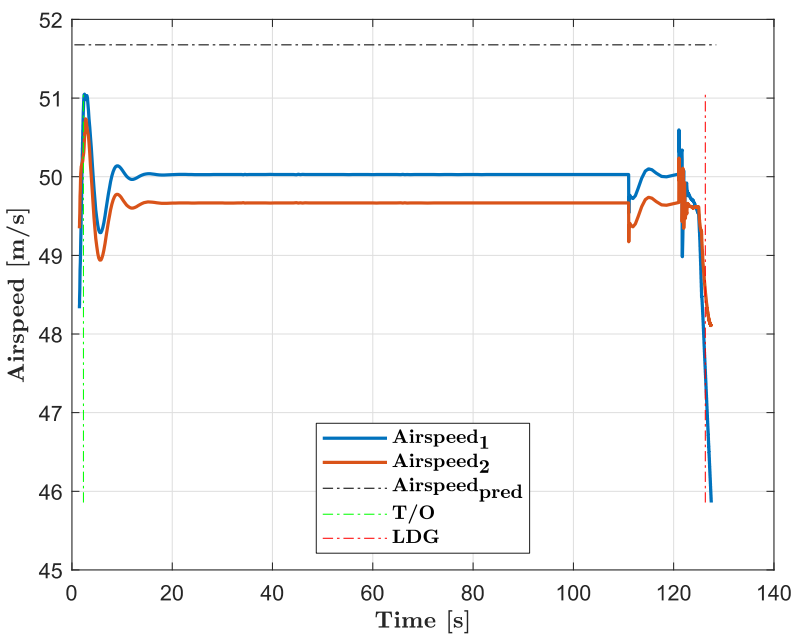
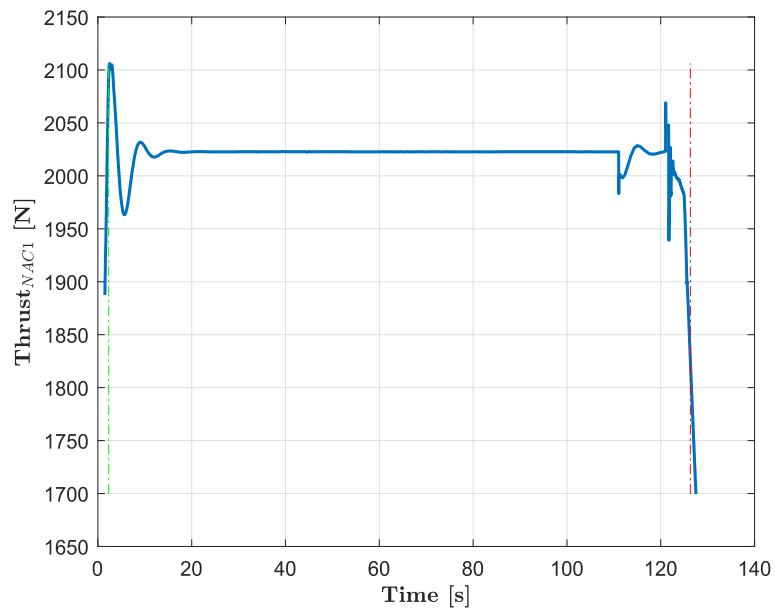
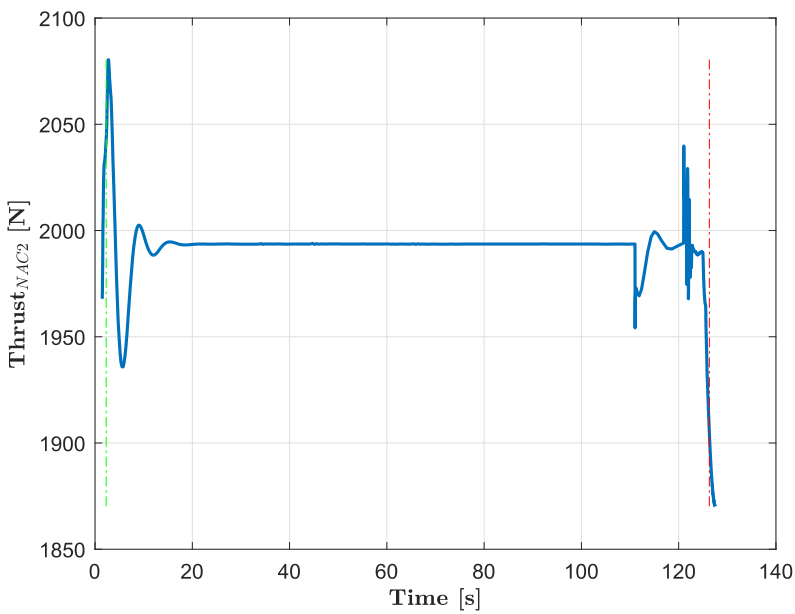

# Conclusions

- **POWER UNIT**

The power unit adopted for the aircraft is the electric motor and battery pack assembly used by Energica Corsa motorbike used in the MotoE world cup championship. The advantages of this choice are several and related to safety, low weight and high performances of the power unit itself. Since the manufacturer did not released any data about weight and dimensions, an estimate has been performed: the power unit assembly has been used considering it as a black box verifying only that power and energy available are enough for the typical flight mission of the aircraft.

- **PNEUMATIC SYSTEM**

The pneumatic system has been sized in order to guarantee safety, performance and control along the vertical axis by means of safety valves, accumulators, reservoir and flow control valves. From a physical model of the system a mathematical model has been designed which allowed a correct sizing and simulation of results. Results obtained are fully satisfactory since the system allows to accomplish the mission (takeoff, hover, vertical position control and landing) through the pedal only.

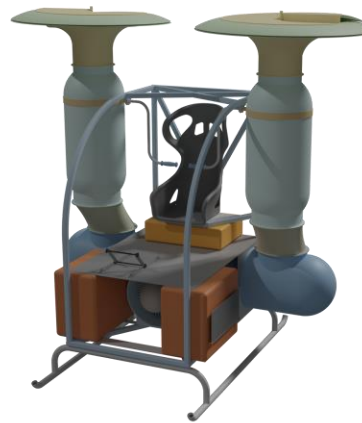

- **PROPULSIVE UNIT AND COMPRESSOR**

The propulsive system has been designed from scratch in order to implement solutions that considerably increase the lift generated by the original design by Leonardo da Vinci. A significant air flow is provided by a compressor that has been sized specifically for this task and is strategically located in the structure. The implementation of state of the art materials such as carbon fiber and 3D printed metal parts allows to achieve the desired geometry, stiffness, and light weight requirements.

- **NUMERICAL MODEL**

The multibody simulation coupled with the automatic flight control system has proven to be able to perform all the correction needed to fly the machine safely and to achieve all the required tasks with accuracy. This multidisciplinary approach has demonstrated that the sizing of the pneumatic system from a conceptual design point of view was correct. The Simulation shows that the maneuverability of the machine is feasible by a human pilot, given the small amounts of force required to stabilize the flying vehicle and the low frequency response dynamics. Nevertheless it is important to highlight that human pilot must be assisted by a automatic control system that takes into account the small variations in thrust required and that processes pilot input consistently.