



# McGill Vertical Flight Society (MVF)

Final Technical Report

DBVF 2022-2023

May 8<sup>th</sup>, 2023

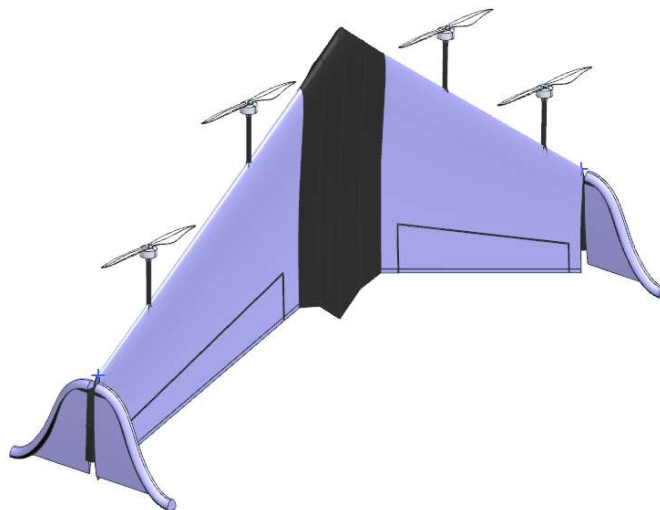

# Summary

## TEAM ORGANIZATION

The McGill Vertical Flight Society (MVF) is a young and vibrant community of eVTOL enthusiasts at McGill University. The goal of our design team is to centralize drone efforts at McGill, spread awareness of the impressive strides of eVTOL technologies and to design and build the best possible eVTOL drones. Each of these goals have their own set of goals to achieve their own set of successes. In MVF, there are a few members dedicated solely to events and spreading awareness, which is not going to be a part of the DBVF competition directly, meaning that we will not go in depth in the workings of that section of the team.

MVF has seen a major reform in the previous semester. As the numerous drone design teams at McGill disbanded over the last few years, MVF has now become a staple of good drone engineering at McGill. As the team increased in number of projects and reliability of the team members, the organization has focused on getting a lot of new members and training them well for the years to come. Focusing on such tasks gives us a good long term investment in members with lasting knowledge for the team to benefit from in the years to come.

The team is currently organized as captains and general members. However, with the ~350% increase in team size this semester alone, we are hoping that some of the most involved members can move to positions of subteam leadership and more as they gain experience.

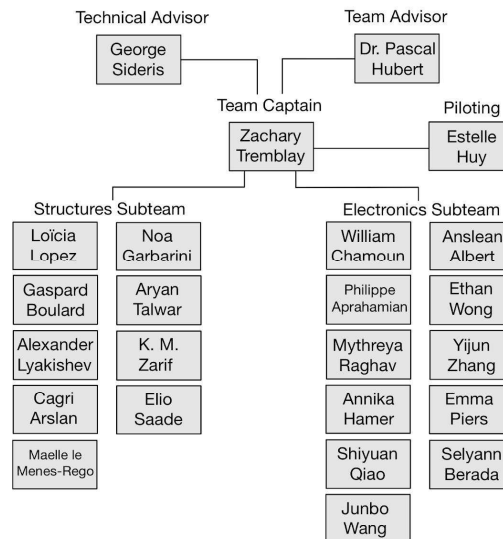

Figure 1, Management Schematics

## Design trade

### MISSION REQUIREMENTS

The first step in the competition process is to determine what are the necessities and what needs to be optimized. These points are highlighted in the Request for proposal.

#### Avionic requirements

The competition requirements can be broken down into two different subsets of requirements, based on the subteams of MVF. The first one being the requirements on the electronics. The main limiting requirement of the competition is to have an electric propulsion system. This includes a maximum of 6S Lipo batteries with no more than 100kWh of power output. There is also a requirement for the electronics to have their independent battery power source, which should be Lipo as well. There are other smaller requirements as well, such as a shunt plug and a kill-switch for safety purposes.

**Structural requirements**

In terms of the structural side of things, there is a limited weight of 20lbs, or 9.07kg, for the combined drone and payload weight. Being a competition where the goal is to carry the most payload, this weight limit sets the main requirements in terms of the hardware side of the competition. There is also a limit in dimensions, which is of a 3m x 3m x 3m box.

**SENSITIVITY OF PARAMETERS AND DESIGN CONFIGURATIONS**

**House of Quality**

To quickly determine which engineering parameters would have the most effects on the drone configuration, it is important to keep in mind the competition requirements. Using a house of quality helps to notice which engineering requirements match the competition requirements the best. Using the following *Figure 2*, it is noticeable that the most important engineering aspects would be centered around efficiency of vertical flight, horizontal flight and the thrust to weight ratio. A note to keep in mind is that even though the price of the parts doesn't have a major effect on the overall performance of a drone for this specific competition, there is a limit in terms of financial budget that we have to set, which caps the overall design.

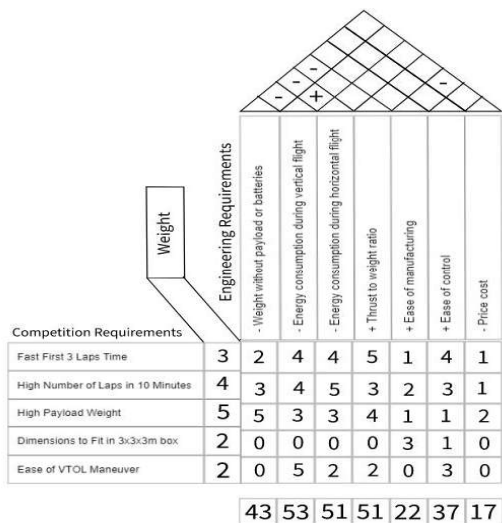

*Figure 2, House of Quality for DBVF 2022-2023*

**Pugh Matrix and Decision Matrix**

The team then referred to pugh matrices and comparison matrices with more technical backings. To get a better sense of which parameters are most important between horizontal and vertical flight, some base assumptions are made and hand calculations provide the approximate time per lap in each setup. Using altered mission model calculations from previous competitions, this results in a time of 14.1 seconds in vertical flight per lap compared to 46.84 seconds in horizontal flight per lap. These numbers provide enough information to highlight that horizontal flight efficiency is around 3 times as important as vertical flight efficiency.









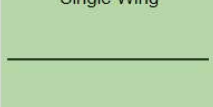

From the house of quality, each configuration has been weighed based on their relation to the competition requirements. However, based on the relationships of each engineering requirement, some of the related points will

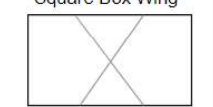
have their points adjusted not to overlap the same positive aspects multiple times. From there, the different tail sitter configurations will be analyzed to determine the ideal scenario for the competition. The following *Figure 3* highlights the characteristics that we determined to be most useful for the competition.

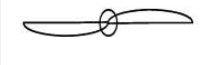
*Table 1, Pugh matrix for different configurations*

Configuration	Tilt-rotor	Xcopter	Lifter-Pusher Dual Rotors	Tail Sitter
Horizontal Flight Efficiency /40	40	30	38	40
Vertical Flight Efficiency /15	13	15	12	13
Thrust to Weight Ratio /40	26	30	23	30
Ease of Manufacturing /10	8	10	8	7
Weight Without Payload /10	5	10	5	8
Ease of Transition /5	2	4	5	4
Stability /5	4	5	4	4
	98	104	95	106

*Table 2, Decision matrix for different characteristics on chosen configuration*

	Option 1	Option 2	Option 3	Option 4	Option 5
Wings	Single Wing 	Dual Wing 	Square Box Wing 	Hexa Box Wing 	
Rotors	Single Rotor 	Dual Rotors 	Quad X Rotors 	Quad - Rotors 	Hexa Rotors 
Body	Wing and Fuselage 	Blended Wing 			

The reasoning for the choice of the single wing was made for the purpose of using the control surfaces. These control surfaces are already necessary to control the aircraft in an efficient manner during horizontal flight, so using them for control during vertical flight would reduce the number of necessary parts and the complexity of the setup. It would also prevent the necessary added weight of the structures to hold multiple wings together. The 3 meter allowed dimension allows for such a configuration, where the large moment of inertia also increases stability in roll. To have high flow on the control surfaces, having 4 rotors on the wings will make the propulsion system more focused around spaces that are affected by the control surfaces. The blended wing design was also chosen for weight reduction methods, as the small electronics that are needed could fit inside of the wing volume.

# Technical Innovations

## LANDING GEAR

### Research

The overarching design goal of the landing gear was to improve performance by minimizing the take-off and landing times. Since our drone will be optimized for horizontal flight, and nearly all vertical flight will occur during take-offs and landings, there is a lot of potential performance that can be gained in this area.

Initial calculations about using a spring assisted system to quickly gain height and speed during take-offs yielded unsatisfactory results. To launch the drone 6 feet into the air roughly 2-3 pounds of springs would be needed as well as a stiffer frame and a motor system to wind the springs. This would harm overall performance due to the weight and extra structural complexity.

Next, a carbon fiber and rubber band engineered jumper design was explored as shown by Hawkes et al. in *Engineered jumpers overcome biological limits via work multiplication* (Nature 604) [1].

Initial results using the simulation code shared were promising, and a simpler system was developed to greatly improve landing times by running the jumper in reverse to absorb impact forces and therefore allow for a much higher landing speed. [2]

### Design

Three designs were developed following the research done.

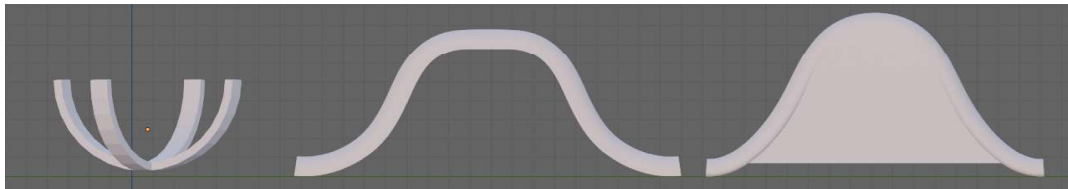

*Figure 3, Design Iterations on the Landing Gear, From the Left, the Hemisphere design, the Recurve Design and the Recurve with Winglet Design*

As well, a modular approach was implemented for all of these. A T-plate was used to connect to the two carbon fiber rods inside the wing, onto which any of these three designs can be mounted, allowing for quick prototyping and iteration later on without compromising on strength of the finished drone.

### Models and Testing

A testing rig is being developed to numerically compare the designs above and different manufacturing techniques. The landing gear will be mounted on a swingarm which would hit the base of the rig. The speed and force of impact can be adjusted by adding weight to the swing arm, and the angle of impact can be varied by raising the impact platform. The final landing gear design has been tested destructively, where it was able to withstand a weight of around 6 lbs per leg at a height of 0.75m into free fall. The addition of rubber bands was considered to be ideal because of its high energy absorption and modularity in terms of elastic strength.



Figure 4: Use of the landing gear test stand to confirm the strength of the landing gear.

## DATA ACQUISITION AND TESTING

### Research

From the team's experience in previous test flights, many problems can arise at this stage of design. This year, a lot of energy and effort has been placed into testing equipment and conventions. Not only has the process been streamlined for flight tests in advance, but there have also been efforts such as the motor test stand and the drone test stand for tests in the later stages of design.

### Design & Models

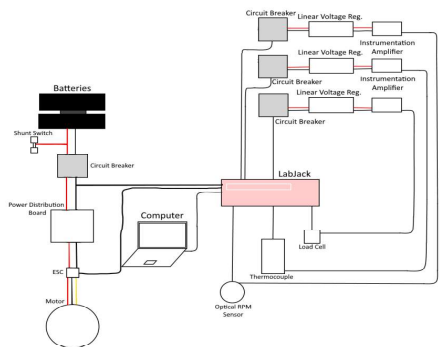

Figures 5 & 6, Motor Test Stand Electronics and Motor Test Stand Hardware

These testing methods are not only for the purpose of this year's competition, but also for the future of the team at McGill. The easier it is for every future member of the team to test their designs, the better they will perform in competitions such as these. As such, future-proofing this test stand was essential, where the diameter of the propellers and the range of the load cell were taken into account to have significantly more capacity than what would support the current design. There is also additional length on the base to allow for the addition of a second arm that could support dual-axis motors.

## MISSION MODEL AND SIMULATIONS

### SITL Simulations and Hand Calculated Mission

Multiple simulations have been made using the software-in-the-loop simulations from MissionPlanner. Performance from xCopters and VTOL configurations have also been compared, to confirm the advantage of VTOLs over the duration of the competition. With an average flight speed of 20 m/s in the VTOL configuration, a time for lap would go in between 50 and 70 seconds, depending on the height of the loiter and the terrain.

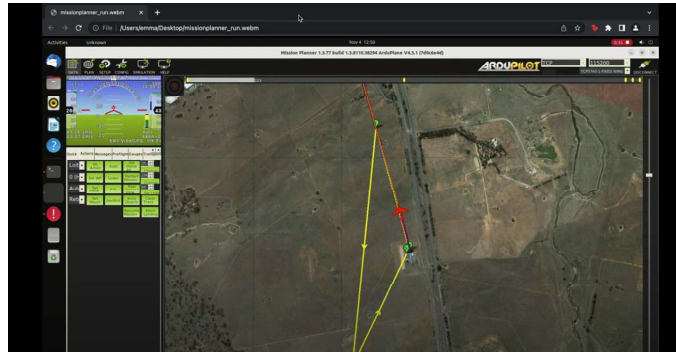

Figure 7, SITL Simulations



Figure 8: Rendering of Possible Flying Environment

The mission has been modeled using hand calculations. Using the drag equation  $D = C_d \rho V^2 A \frac{1}{2}$  [4] and assuming a coefficient of drag of 0.4 as from the airfoil's provided data [5], a maximum speed of 20m/s, a 1 second delay for approval of each VTOL landing, a weight of the full 9.07kg, a thrust to weight ratio of 2 on average and constant winds of around 5 m/s, it has been calculated that the average speed per lap of our aircraft would be of around 54.25s. However, if we increase the thrust to 90% for the first three laps, our thrust to weight ratio then becomes 2.3. This increases the time per lap to around 49.25s. To then get the battery capacity, a configuration with 13500mAh was assumed, which resulted in a possible 11 laps, where it is expected that pilots would be able to squeeze 9 or 10 depending on performance.

## ELECTRONIC SYSTEMS

### Avionics

The avionics, in general, are pretty standard. The flight controller used by the team is the PixHawk Cube Orange for autonomous flight capabilities. Another addition that MVF has made this year is the implementation of an FPV camera, as the drone will now be going much further from the pilot than in previous competitions. This FPV camera also has a gimbal system, which will use an Arduino nano BLE Sense to measure the direction in which the co-pilot's head is pointed. This Arduino BLE Sense is related to the controller's telemetry using an aux cord, as per an online tutorial's setup [6]. To measure the voltage of the battery, the PDB will also be connected to the flight

controller to provide accurate information on the battery voltage in order to give the pilot valuable information on the state of the drone's capacity.



Figure 9, Electronics Diagram

**STRUCTURES SYSTEMS**

Aerodynamics

Our main use of aerodynamics is through the wings. After careful evaluation of the theory, such as in [4], it was evaluated through a pugh matrix that the best outcome would be the A18 airfoil.

Table 3, First Entries of the Analysis of airfoils

Airfoil	Model	%Thickness	%Camber	Cm,c/4	Description
A18	Free flight	7.26	3.84	-0.126	-Good performance in climb and glide (especially glide)
BE50	Free flight	7.31	3.96	-0.114	-Best endurance over a broad Cl range coefficients (broad speed range) - Less sensitive to trim changes in glide
GM15	Free flight	6.70	4.76	-0.154	- Flapper airfoil (airfoil with a plain flap that is reflexed (low camber) in climb and unflapped (high camber) in glide) - Good balance ...

There also have been multiple decision matrices for the propulsion system, where the MAD5010 310kv won for its price and quality.

Table 4, Comparison Matrix of Propulsion System.

Combinations ranking	Motor model	Propeller Model	total thrust (g)	Estimated flight time (min)	Number of motors required	total motors weight (g)	total propellers weight (g)
1- best overall	MAD 5010 V3 310KV	Fluxer Pro 18x6.1 MATT	18212	7	4	704	1
2- good option disregarding costs	MAD 5010 V3 310KV	Fluxer Pro 17x5.3 MATT	19460	6	4	708	2
3- better option disregarding weight and costs	P60 Pin KV170	P20*6 Prop	18738	11.3	3	1125	2
4- better option disregarding weight and costs	P60 Pin KV170	P20*6 Prop	24884	8.5	4	1500	3
5- best budget	MAD 5008 400KV	Fluxer Pro 17x5.8 MATT	16288	7	4	592	1
6- very good but expensive option	P90 III Pin KV120	G30*10.5 Prop	18256	11.5	1	648	1
7	MAD 5001 LEE 350KV	Fluxer 16 1x5.4 VTOL PROP	16824	8	4	612	1
8	MAD 3515 650KV	Fluxer Pro 13x4.4 MATT	21540	4	4	912	1
9	MAD 5008 LEE V2.0 340KV	Fluxer Pro 17x5.8 MATT	20190	7	4	780	1

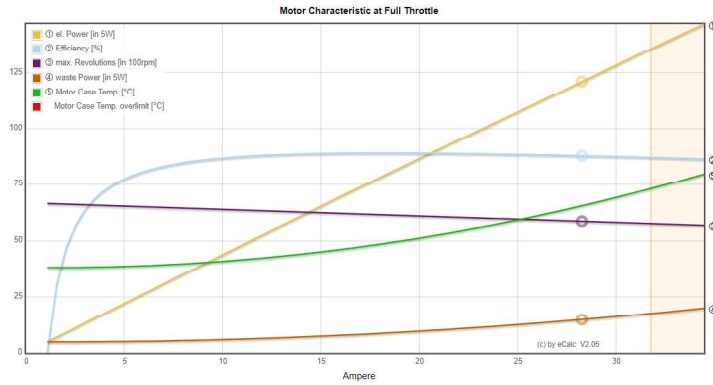

Figure 10: Motor characteristics at full throttle using e-calc [7]

Alternatively, each cross section was analyzed using a customized STL file representing the shape of the drone’s wings. After numerous simulations, the one with the highest lift/drag ratio and the least concentrated forces was selected. Using the CFDs, considerable vortices were noticed on the edges of the wings, confirming the presence of well-integrated landing gears. Spars were also positioned in areas prone to the most forces.

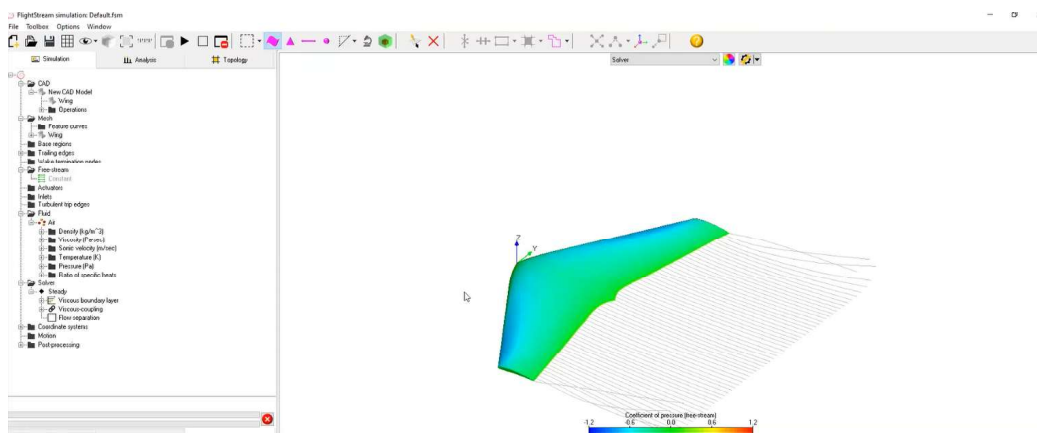
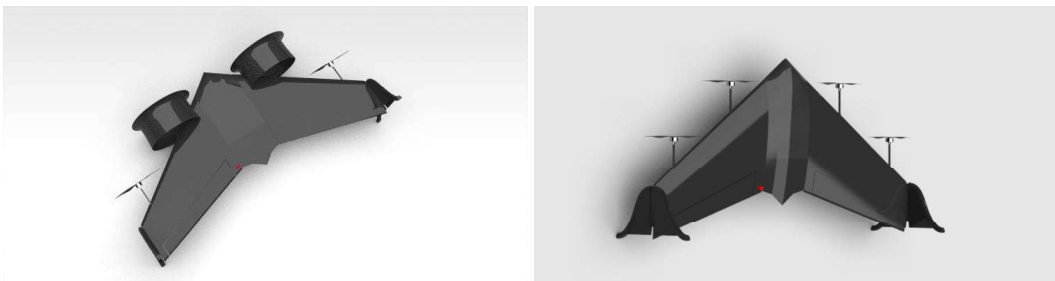

Figure 11: CFD of the Tested Cross Section in Accordance to the Drone Geometry

Following CFDs showed that there was significant turbulence in the flow after the propellers. To increase the efficiency of the ailerons’ movement, it was decided to add a testing stage for propeller ducts. This add-on system for the propeller ducts will be optional and further tested during the flight tests or on the motor test stand to determine if the ducts are worth more than their weight. The following render shows the option of added propeller ducts.



Figures 12 and 13: Drone Setup With and Without Propeller Ducts

## Drawing Packages

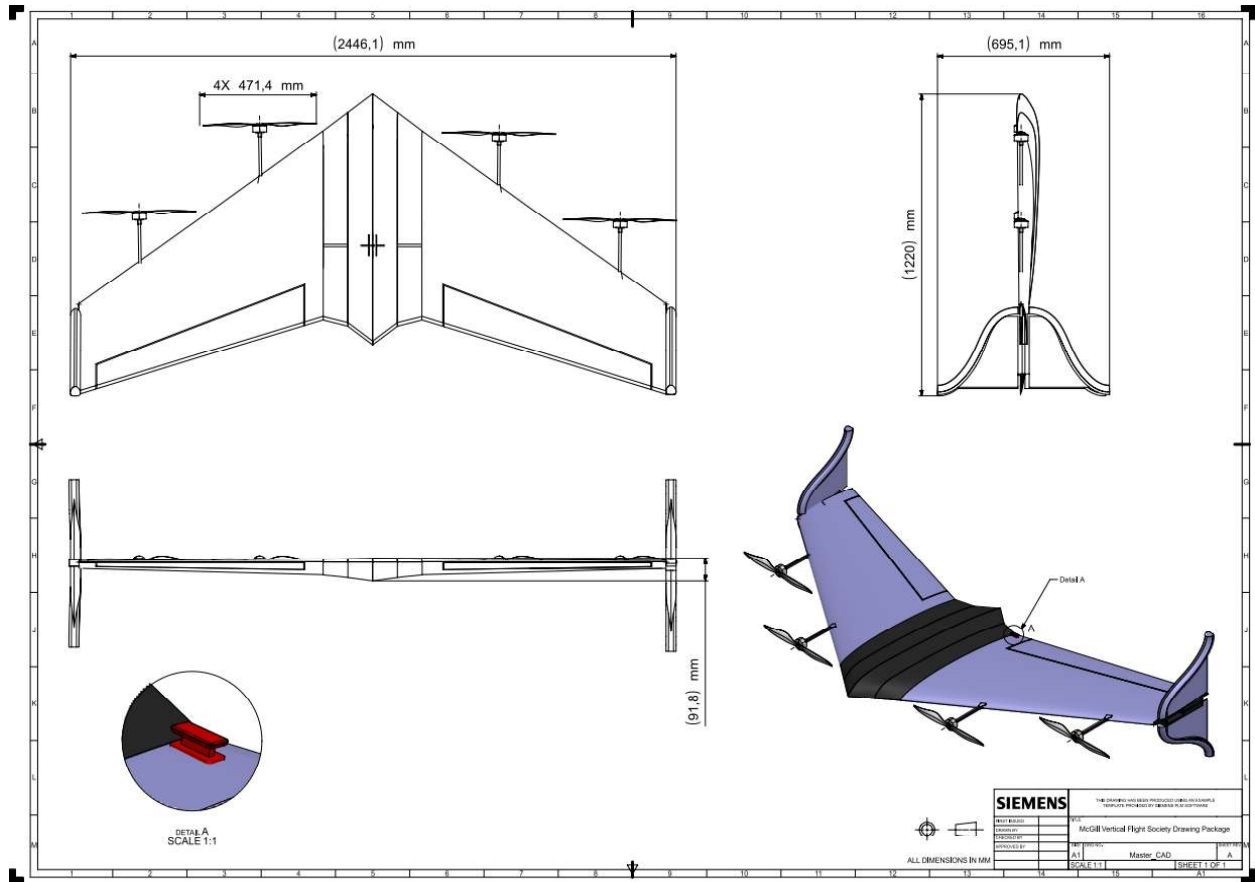

Figure 14: Drawing Package for the Drone Without Propeller Ducts

## Manufacturing

### FRAME:

Our frame is the rigid skeleton where the rest of the parts are assembled. It is designed to support the weight of the drone in addition to that of the attached payload for a safety factor of 1.3 as validated through FEA. It consists of two front and two rear spars, two ribs, four protruding motor mounts, and a central support; all made of carbon fiber tubes and connected to each other through a set of carbon fiber brackets. Stock carbon fiber parts cut to shape and size were used almost exclusively to make the frame due to the material's low density and high strength-to-weight ratio.

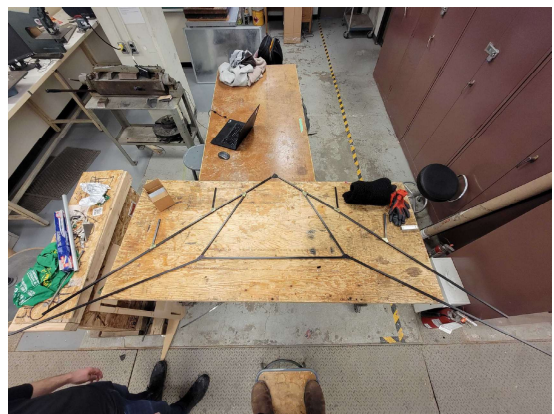

Figure 15: Drone's Planned Spars and Connections

## WINGS:

Our wings are made out of expanded polystyrene (EPS) foam due to the material's low density, high rigidity, and ease of manufacturing. A custom hot-wire cutter was created with a large enough wire length of around 4 feet to allow the formation of each wing from a stock of foam. The wire cutter was used to cut pieces following the laser cut A18 airfoil cross-section, which were then detailed using carving knives before being sanded down to a smooth finish, giving them their final, as-designed form. Grooves were made on the underside of the wings to allow for their attachment to the frame, as well as to create space for wiring. Adhesive was used at the grooves to connect the wings to the frame. The wings were then hardened and covered with a thin, plastic, heat-sealed membrane to cover the grooves and ensure a smooth profile.



*Figure 16 & 17: Wings and Spars Integration & Use of Custom Hot Wire Foam Cutter.*

## FUSELAGE:

The fuselage was designed to house all our electronics as well as the payload while retaining structural rigidity and aerodynamic stability. Similar to the wings, the A18 airfoil cross-section was used for the outer shape of the fuselage, albeit scaled to a size that would create the volume necessary to accommodate the electronics and payload while resulting in minimal empty space. The fuselage was made out of carbon fiber twill sheets formed to shape through wet lay-up. A positive mold was first created using EPS foam, on which 3-ply carbon fiber sheets were laid-up and resin-infused twice, forming the upper and lower side of the fuselage respectively. The pieces were finished through additional infusion to fill cavities and sanding to achieve a smooth finish.



*Figure 17: Wet Layup of Fuselage Using a Foam Mold*

## **LANDING GEAR:**

The landing gear was designed to ensure structural integrity, stability, and shock absorption in take-off and landing while doubling as a set of winglets in cruise flight. Similar to the fuselage, the landing gear was made out of carbon fiber twill sheets formed to shape through wet lay-up. In this case, a negative mold was 3D-printed using PLA, in which 3-ply carbon fiber sheets were laid-up and resin-infused to create four sigma-shaped pieces from which the landing gear was assembled. The design of the landing gear is discussed in greater detail under the Technical Innovations section.



*Figure 18: Wet Layup of Landing Gear Using a 3D Printed Mold*

## **Test Plan**

The first of our tests were meant to be carried out on a system-by-system basis, followed by integration of multiple systems before confirming the whole system with a flight test.

### **LANDING GEAR TEST:**

The landing gear system was tested rigorously using a customized testing rig. More details are provided in the “Technical Innovation” section.

### **TELEMETRY RANGE TEST:**

Controller distance was confirmed using the finished electronics setup and the controller. Going out into the field, it was noticed that the controller achieved well over the necessary distance. Tests were stopped after the controller proved successful at a distance of 700m, which gave us a safety factor of 1.75 as compared to the competition requirements.

As for the ground control station data, the same telemetry range tests were conducted. However, initial tests proved unsuccessful, where the range was much less than what was necessary. As such, the AirRate parameter in MissionPlanner was altered until a satisfactory range of around 300m.

As for the video transmission modules, few tests were performed with an omni antenna similar to that of the SiK radio used for ground control telemetry. However, this proved inefficient as a range increase would cause dramatic latency and frame rate issues. Following this problem, a patch antenna was used to counter this problem. However, this would limit the head movements of the drone’s pilot. Considering this drawback, additional pilot and co-pilot training has been integrated into the development of a competition-worthy pilot.

### **WING LOAD TEST:**

The wing load test was meant to demonstrate the capabilities of the wings of the drone to hold up weight similar to that of flight conditions. The wings were tested in an unfinished state, without the use of the hardener, membrane or other structural add-ons to the wings, which yielded positive results despite a heavy load. The following figure demonstrates the early wing-load test.

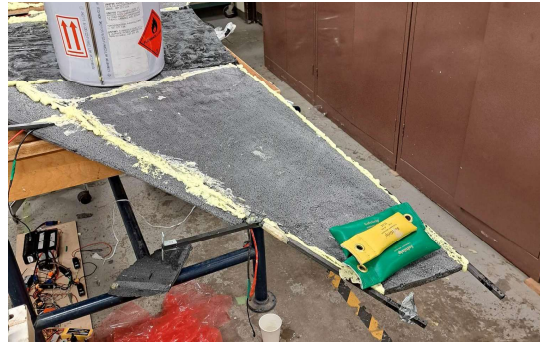

*Figure 19: Wing Load Test*

Although other additions to the wings have made them stronger, another wing load test will be performed once all additions have been made to confirm that no mistakes have been made during manufacturing.

### **ELECTRONIC SYSTEMS INTEGRATION:**

The electronics of the drone system were all put in place and tested on a specific removable plate that will be located inside of the drone's fuselage. This plate will help facilitate the calibration of different systems during competition, as there would be a need to move the whole drone. Double sided foam tape was used to counter vibrations as well as gel-like supports underneath the removable plate. Once the electronic systems were confirmed, tests ensured that the right controller and headset inputs caused the right movements on the drone. The following figure represents the integration of the electronic systems. Every test proved successful through a series of upgrades.

### **TAILSITTER BENCH TEST:**

A custom tailsitter bench testing rig has been created for the purposes of calibrating and setting up the drone before any actual flight is done. The integration of electronics and structural projects will be tested in this step. There is currently not enough available space in the workshop for the team to follow through with this test, which will be reported until outside conditions allow for valuable data to be provided.



*Figure 20: Tailsitter Bench Test Rig*

## Test Results

All tests that have been attempted yet have all ended successfully, which allows the team to proceed to flight tests.

The initial landing gear tests, done with the same geometry, but with pvc instead of carbon fiber, helped discover a significant weakness in the geometry of the layup. Therefore, for suspension purposes, it was decided that either a spring or rubber bands would help the overall toughness of the setup. Rubber feet were also added to the design to help the load to be spread throughout the landing gear instead of the most curved sections, as seen in the following figure.



*Figure 20: Landing Gear Upgrades After Tests*

The telemetry tests helped discover the best AirRate for the ground control station telemetry as well as the best antennas for the video transmission module.

As for the electronics integration system, it was very useful for team members to familiarize themselves with the purpose of the setup. The integration of structural components, such as horizontal and vertical transitions, aileron movements and center of gravity positioning has helped to fine tune the parameters before flight.

However, a main lesson that was learned in the previous years was to beware of flight tests. Before any actual flight can be attempted, the team is also designing removable propeller guards, doubles of electronic parts, a battery recharging station, damping nets, procedure checklists and much more. Test flights will be conducted under the supervision of the team advisors to ensure the proper functioning of the drone. It is expected that the environment

# Schedule

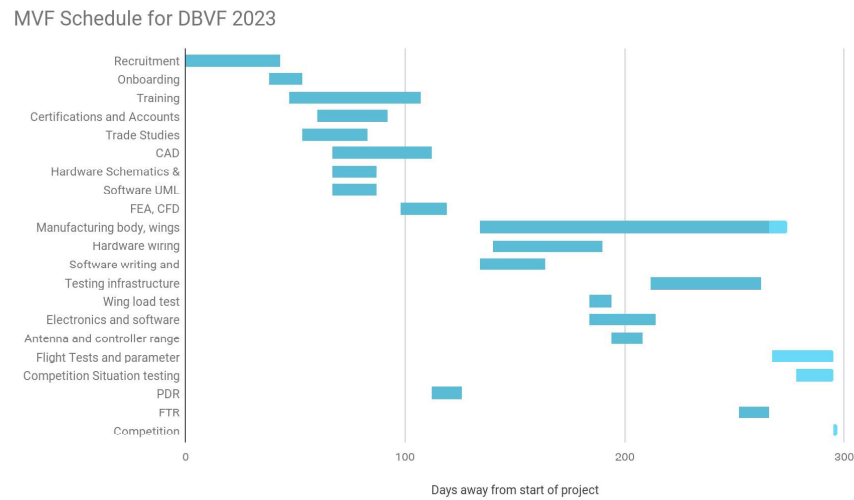

Figure 21, Schedule of the Year's Goals and Deliverables

## Works Cited

[1] Hawkes, E.W., Xiao, C., Peloquin, R.A., et al. "Engineered jumpers overcome biological limits via work multiplication." *Nature*, vol. 604, no. 8157, 2022, pp. 657-661. doi: 10.1038/s41586-022-04606-3.

[2] "Final Project Documentation." University of Idaho, Fall 2017. [https://www.webpages.uidaho.edu/mindworks/CATIA/Past%20Projects/Fall\\_2017/Drone%20Project/Final%20Project%20Documentation.pdf](https://www.webpages.uidaho.edu/mindworks/CATIA/Past%20Projects/Fall_2017/Drone%20Project/Final%20Project%20Documentation.pdf).

[3] Selig, Michael S. "Low-Speed Airfoil Data, Volume 1." University of Illinois at Urbana-Champaign, 1995. [https://m-selig.ae.illinois.edu/uiuc\\_isat/Low-Speed-Airfoil-Data-V1.pdf](https://m-selig.ae.illinois.edu/uiuc_isat/Low-Speed-Airfoil-Data-V1.pdf).

[4] "The Drag Equation." NASA Glenn Research Center. <https://www.grc.nasa.gov/www/k-12/rocket/drageq.html#:~:text=The%20drag%20equation%20states%20that,times%20the%20reference%20area%20A>.

[5] "Airfoil details: NACA 18-IL-25." Airfoil Tools. <http://airfoiltools.com/airfoil/details?airfoil=a18-il>.

[6] "Head Tracker." GitBook. <https://headtracker.gitbook.io/head-tracker/>.

[7] "eCalc - electric drive calculation." eCalc.ch. <https://www.ecalc.ch/>.  
Regenerate response