



PennState
College of Engineering



Vertical Flight
Society



NIGHT FURY

Executive Summary

The Penn State Team

Julian Hauff – Andrew Crotts – Matt Anderson – Ryan Hoffman – Sung Hyeon Lee – Owen Mable – Joseph Madden – Owen Williams – Lucas Brown

Presenting: the *NIGHT FURY*

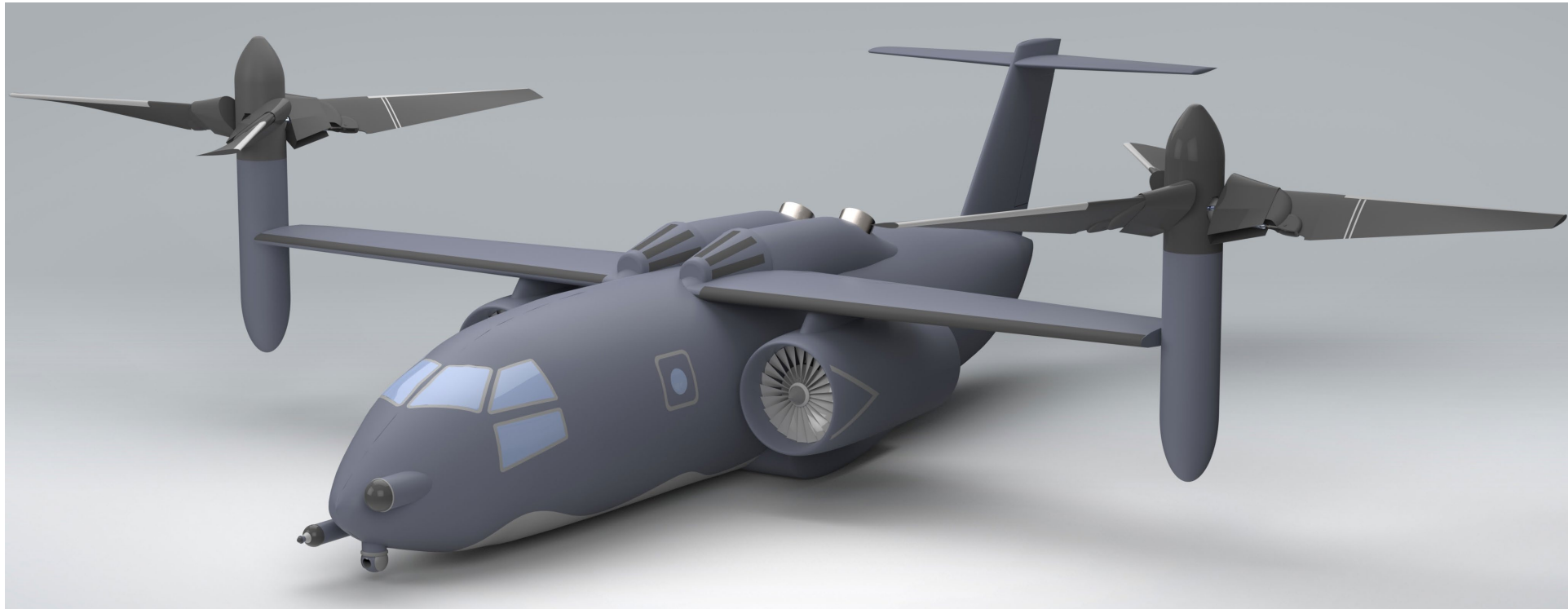

The Night Fury is a military transport aircraft capable of vertical landings and takeoffs like a conventional tiltrotor. It differs with respect to vehicles like the V-22 or the V-280 by having the ability to achieve transonic cruise speeds after takeoff, making long-range, high-speed missions possible. The aircraft can achieve this by using **folding rotor technology** that enables it to fold its rotors onto the nacelle after transitioning from hover to rotor cruise.

Different Configurations Optimized for Varying Flight Conditions

The Night Fury solves HSVTOL design challenges using an innovative folding rotor technology combined with a tiltrotor configuration

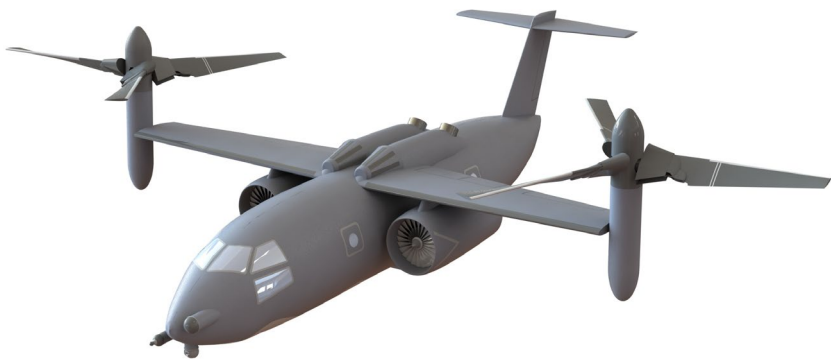

Hover



Proprotor



Cruise

Two main HSVTOL design challenges:

- Efficient and **low downwash hover (low disk loading)**
- High speed of **450 kts at high altitude of 20,000 ft**

The Night Fury uses a unique **folding rotor system** to meet both competing objectives

- Allows one vehicle to possess both low downwash and high cruise speed

Cruise Configuration: 3-View Drawing

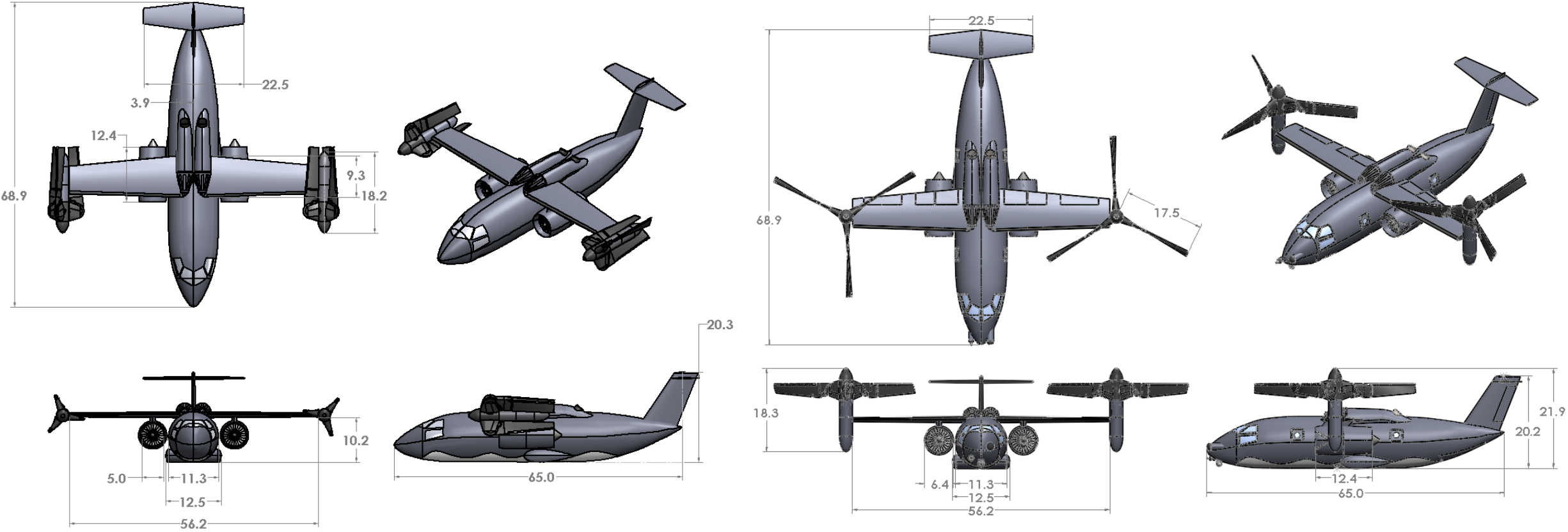

Dimensions in [ft]

Mission Profile

Outbound Trip

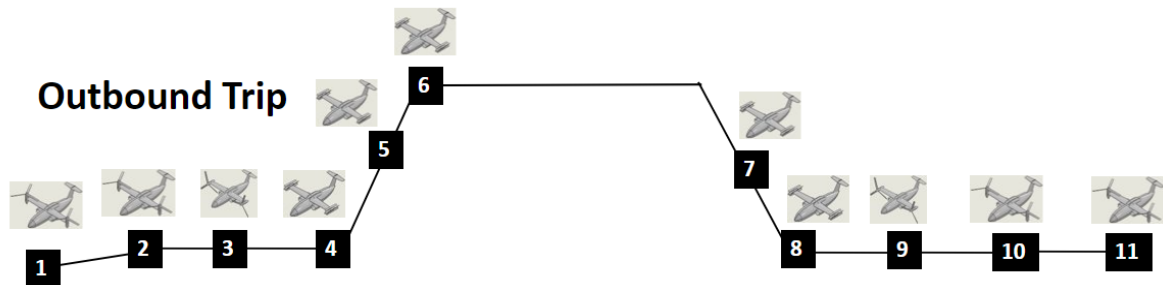

Phase 1: Idle <ul style="list-style-type: none"> • 10 min • Helicopter Mode • 0 ft • 0 kts • 0 nm 	Phase 2: Hover <ul style="list-style-type: none"> • 2 min • Helicopter Mode • 2,000 ft • 0 kts • 4,150 Hp • 0 nm 	Phase 3: Rotor Tilt <ul style="list-style-type: none"> • >1 min • Helicopter to Propeller Mode • 2,000 ft • 30-160 kts • 0.4 nm 	Phase 4: Rotor Fold <ul style="list-style-type: none"> • >1 min • Propeller to Jet Mode • 2,000 ft • 170 kts • 2,830 Hp • 0.4 nm 	Phase 5: Climb <ul style="list-style-type: none"> • 3.31 min • Jet Mode • 2,000-20,000 ft • 230 kts • 5,363 Hp • 12.3 nm 	Phase 6: Cruise <ul style="list-style-type: none"> • 60 min • Jet Mode • 20,000 ft • 450 kts • 12,362 Hp • 450 nm 	Phase 7: Descent <ul style="list-style-type: none"> • 1.95 min • Jet Mode • 20,000-2,000 ft • 450 kts • 2,123 Hp • 14.3 nm
Phase 8: Penetration <ul style="list-style-type: none"> • 8 min • Jet Mode • 2,000 ft • 375 kts • 7,700 Hp • 50 nm 	Phase 9: Rotor Unfold <ul style="list-style-type: none"> • >1 min • Jet to Propeller Mode • 2,000 ft • 170 kts • 2,830 Hp • 0.4 nm 	Phase 10: Rotor Tilt <ul style="list-style-type: none"> • >1 min • Propeller to Helicopter Mode • 2,000 ft • 160-30 kts • 0.4 nm 	Phase 11: Hover <ul style="list-style-type: none"> • 2 min • Helicopter Mode • 2,000 ft • 0 kts • 2,359 Hp • 0 nm 			

Return Trip

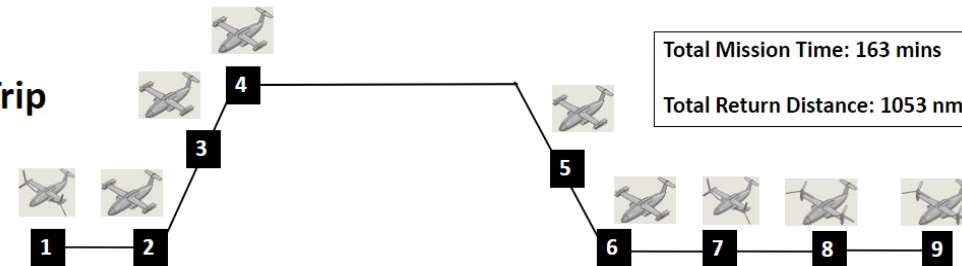

Total Mission Time: 163 mins

Total Return Distance: 1053 nm

Phase 1: Rotor Tilt <ul style="list-style-type: none"> • >1 min • Helicopter to Propeller Mode • 2,000 ft • 30-160 kts • 0.4 nm 	Phase 2: Rotor Fold <ul style="list-style-type: none"> • >1 min • Propeller to Jet Mode • 2,000 ft • 170 kts • 2,830 Hp • 0.4 nm 	Phase 3: Climb <ul style="list-style-type: none"> • 3.31 min • Jet Mode • 2,000-20,000 ft • 230 kts • 5,363 Hp • 12.3 nm 	Phase 4: Cruise <ul style="list-style-type: none"> • 60 min • Jet Mode • 20,000 ft • 450 kts • 12,362 Hp • 450 nm 	Phase 5: Descent <ul style="list-style-type: none"> • 1.95 min • Jet Mode • 20,000-2,000 ft • 450 kts • 2,123 Hp • 14.3 nm
Phase 6: Penetration <ul style="list-style-type: none"> • 8 min • Jet Mode • 2,000 ft • 375 kts • 7,700 Hp • 50 nm 	Phase 7: Rotor Unfold <ul style="list-style-type: none"> • >1 min • Jet to Propeller Mode • 2,000 ft • 170 kts • 2,830 Hp • 0.4 nm 	Phase 8: Rotor Tilt <ul style="list-style-type: none"> • >1 min • Propeller to Helicopter Mode • 2,000 ft • 160-30 kts • 0.4 nm 	Phase 9: Hover <ul style="list-style-type: none"> • 2 min • Helicopter Mode • 2,000 ft • 0 kts • 4,150 Hp • 0 nm 	

Total Mission Time: 163 minutes
Total Return Distance: 1053 nm

Initial Concepts Analyzed

1. Stop-Fold Tiltrotor [SELECTED]

Open rotor system for hover, folds rearward for cruise

- ++ Lowest downwash
- + High speed, low drag fuselage
- Requires auxiliary thrust for cruise



2. Variable-Diameter Tiltrotor

Variable advance ratio proprotor for hover and cruise

- ++ No auxiliary propulsion
- + Conventional tiltrotor configuration
- Extremely low efficiency in high-speed cruise

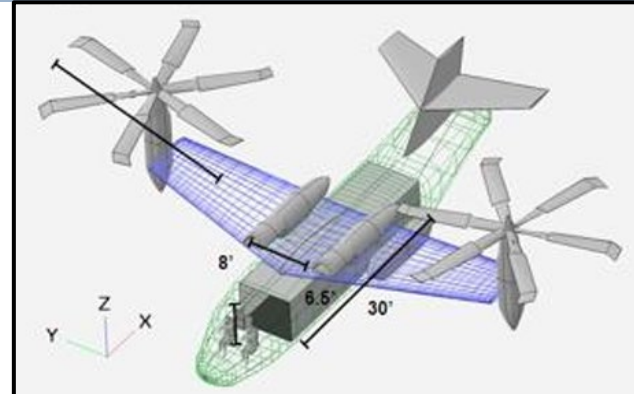

3. Fan-in-Wing

Lift-fan system for hover, stows for cruise

- + High speed, low drag
- High hover power requirement
- Extremely high downwash

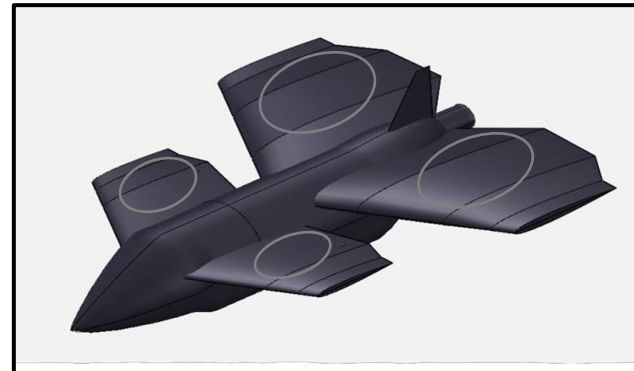

Trade Study Down Select Using AHP Process

Choose metrics, calculate or rate as a group

Assign preference weights and normalize values (based on RFP importance)

FOD, safety rated 1-5 rather than calculated

Sum normalized values and rate each vehicle overall

Metric	Goal	Preference Weight	Fan in Wing	Tiltrotor, Folding Blades	Tiltrotor, Variable Diameter
Delta GW	Min	5%	5.87	55	0.072
<i>Normalize Value</i>			0.894	0	1
TOGW	Min	10%	37800	35600	44600
<i>Normalize Value</i>			0.757	1	0
Total Length	Min	5%	65.1	59	62
<i>Normalize Value</i>			0	1	0.510
Total Width	Min	5%	50.8	58	82.5
<i>Normalize Value</i>			1	0.772	0
Total Height	Min	5%	21.5	16.5	18.5
<i>Normalize Value</i>			0	1	0.6
Useful Load Ratio	Min	10%	0.594	0.45	0.6
<i>Normalize Value</i>			0.0387	1	0
Power Req	Min	10%	26000	12900	26600
<i>Normalize Value</i>			0.0461	1	0
Disk loading	Min	25%	39.6	19.7	35
<i>Normalize Value</i>			0	1	0.231
FOD ingestion Mitigation Rating	Max	15%	4	5	4
<i>Normalize Value</i>			0	1	0
Safety	Max	10%	3	4	4
<i>Normalize Value</i>			0	1	1
Total Preference Score:		100%	17.9%	93.9%	26.3%

Trade Study Selection Criteria

- Disk loading, FOD ingestion mentioned the most in RFP with hard limits on disk loading
- The useful load ratio for the folding tiltrotor was much lower than the others which means less risk for the vehicle
- Weights and power all were within reason but still limited the vehicle
- Safety was considered since vehicle will operate in a contested environment

The folding tiltrotor had the highest trade study rating and would become the Night Fury

Vehicle Parameters (Comparison with CV-22B)



Parameter	Night Fury	CV-22B
Max Gross Weight	47,200 lbs (21,400 kg)	52,600 lbs (23,860 kg)
Disk Loading (Hover)	26 lbs/ft ² (1.245 kN/m ²)	20.9 lbs/ft ² (1.001 kN/m ²)
Angular Velocity	446 RPM [HOVER] 357 RPM [CRUISE]	412 RPM [HOVER] 333 RPM [CRUISE]
Figure of Merit	0.72	0.78
Transition speed, <i>Hover → Cruise_{rotor}</i>	125-160 KTAS	80 KTAS
Transition speed, <i>Cruise_{Folded}</i>	160-170 KTAS	NA
Cruise Speed	450 KTAS	270 KTAS
Max Speed	480 KTAS @ 20,000' ASL	305 KTAS @ 15,000' ASL
Payload Volume	1560 ft ³ (44.2 m ³) 6.5' x 8' x 30' (2 x 2.4 x 9 m)	864ft ³ (24.5 m ³) 6' x 6' x 24' (1.8 x 1.8 x 7.4 m)
Stall Speed	114 KTAS (218 km/h) [Full Flaps]	110 KTAS
Wing Area	448 ft ² (41.6 m ²)	301 ft ² (28 m ²)
Limit Load max/min (Airplane)	3.5 / -1.4	3 / -0.78
Estimated Base Cost	\$110.5 M	\$105 M



Custom Wing Airfoil: SC-14 Night Blade

- No existing airfoil fit mission
- Designed in X-Foil
- Started with SC(2)-0518
- Altered geometry
 - Camber \rightarrow +25%
 - L/E Radius \rightarrow - 50%
 - Thickness ratio \rightarrow 14.4% thick
- Validated cruise conditions in X-Foil
- Added flaps
 - Decrease stall speed
 - Decrease transition speed

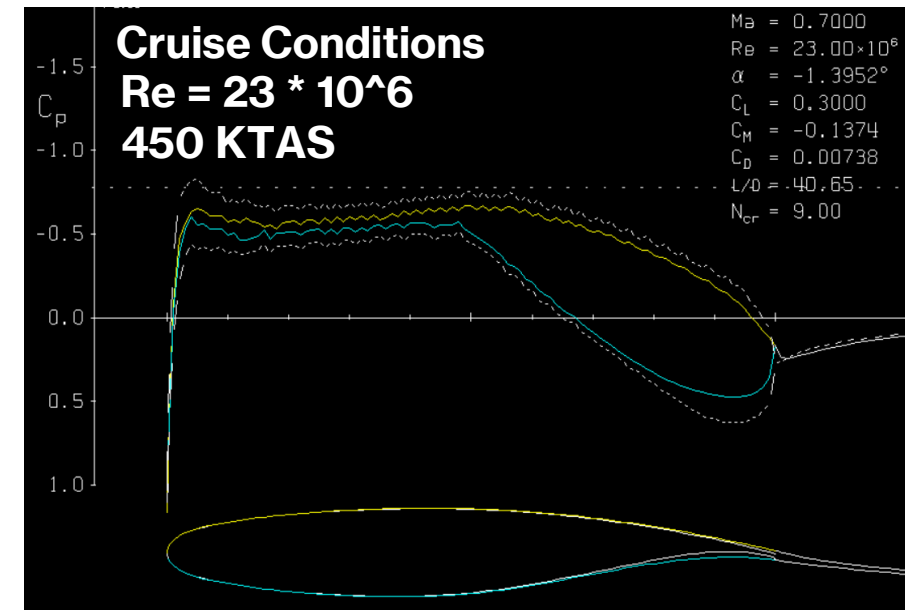
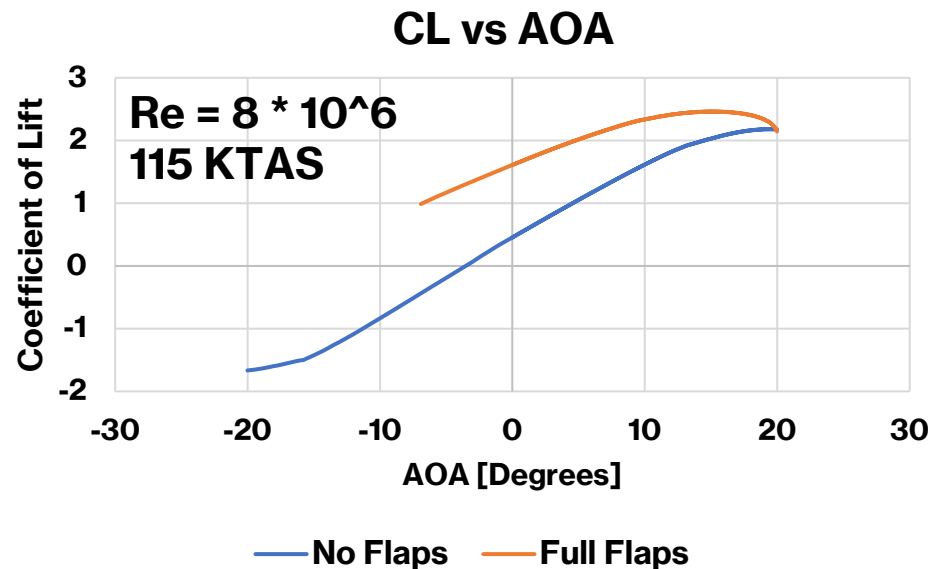
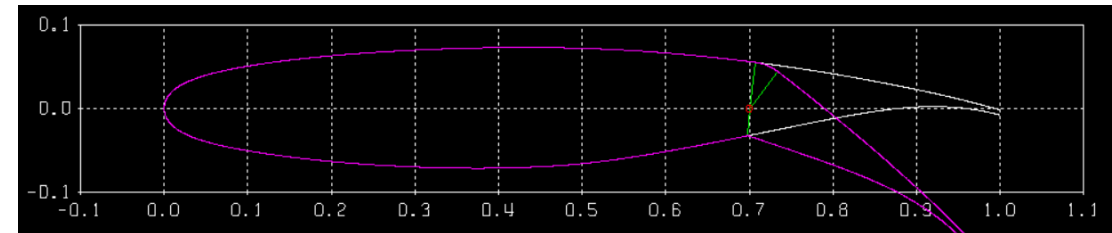

Wing Structure: Hover/Cruise Stress

- Semi-span: 28 ft (8.53 m)
- Root Chord: 9.73 ft (2.97 m)
- Tip Chord: 6.27 ft (1.91 m)
- Max thickness: 16.8 in (0.427 m), 14.4% thick
- Material: Aluminum 2024-T3
 - Lower cost than alloys like 7075-T6
- Fuel tanks hold 3190 lb. (1447 kg) per wing (remaining fuel stored in fuselage)

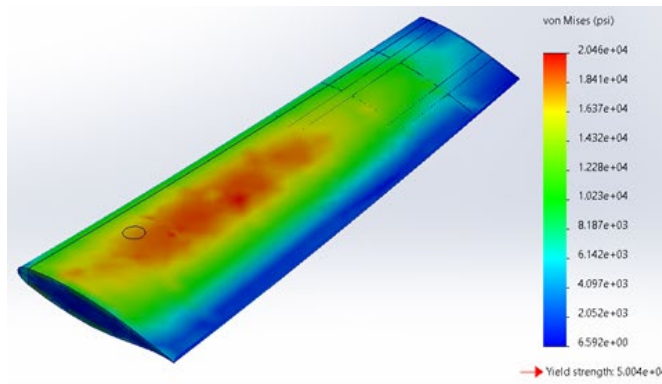
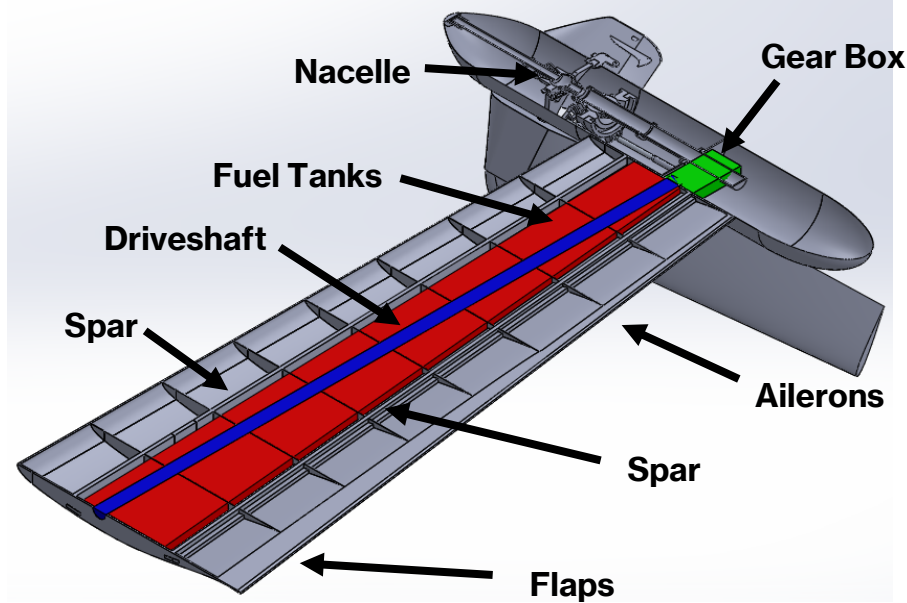

Wing loading [HOVER]
Load factor: 1.5

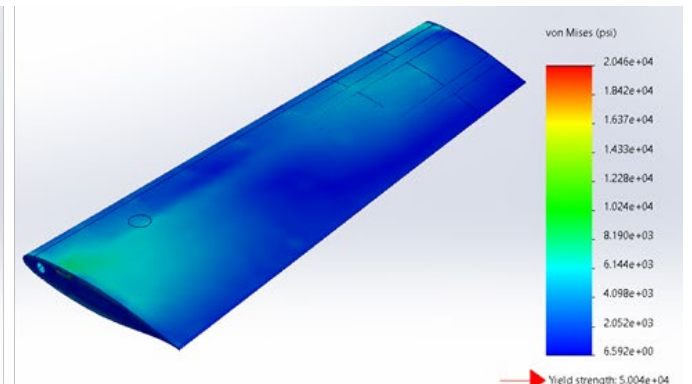

Wing loading [CRUISE]
Load factor: 3.5

Rotor Hub and Folding Mechanism

GOAL: Stow the rotor blades parallel to freestream flow to minimize drag in forward flight

- Idea explored by Bell Helicopter as early as 1972, in development since then
- Mechanism patent approved in 2015

Initial Specifications:

3 blades
35' rotor diameter
3' blade chord (root)

Concept is derived from this work, modified, and sized to meet initial specifications and needs

- Modeled in SOLIDWORKS to demonstrate functionality

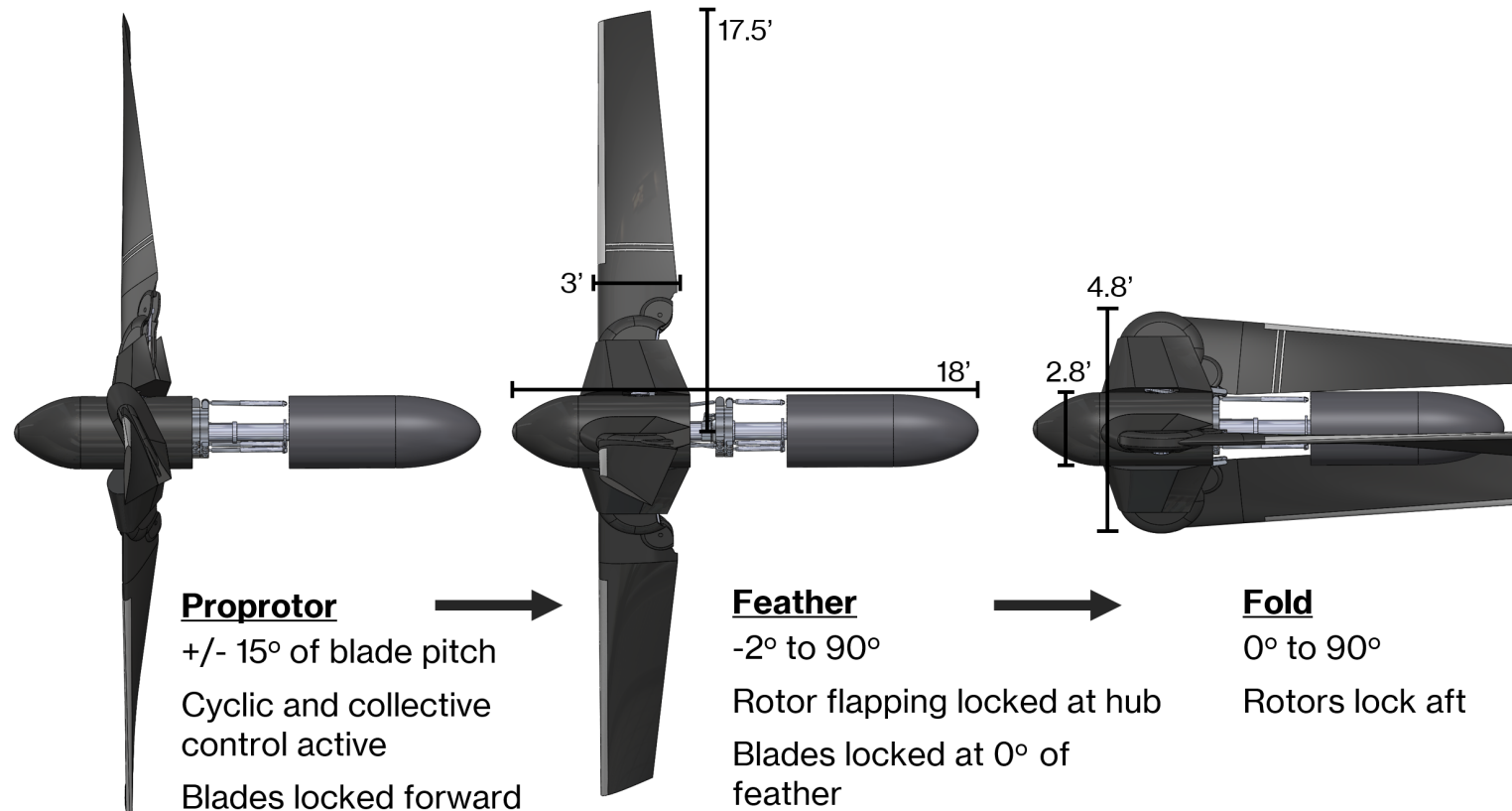

Principle of Operation and Proof of Concept

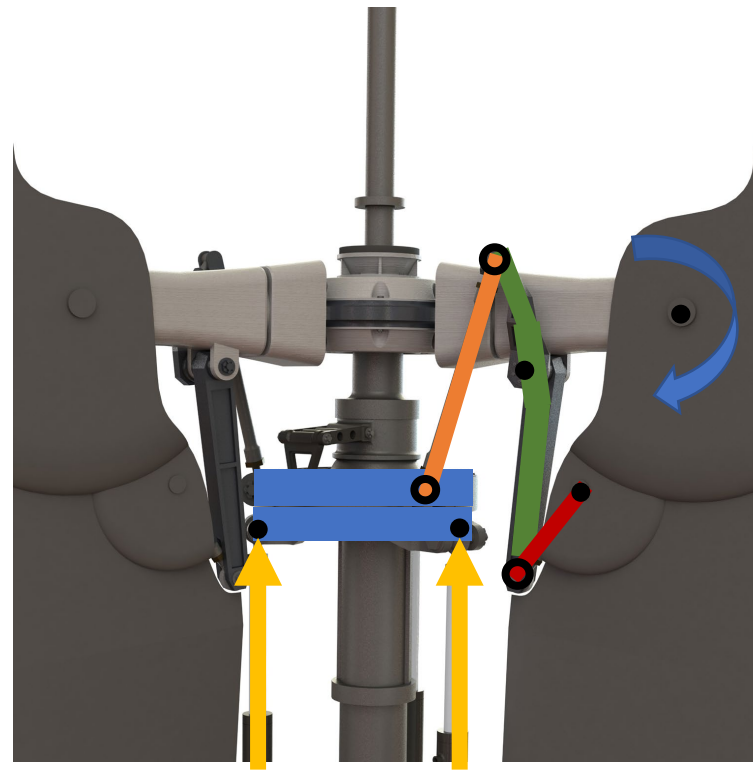
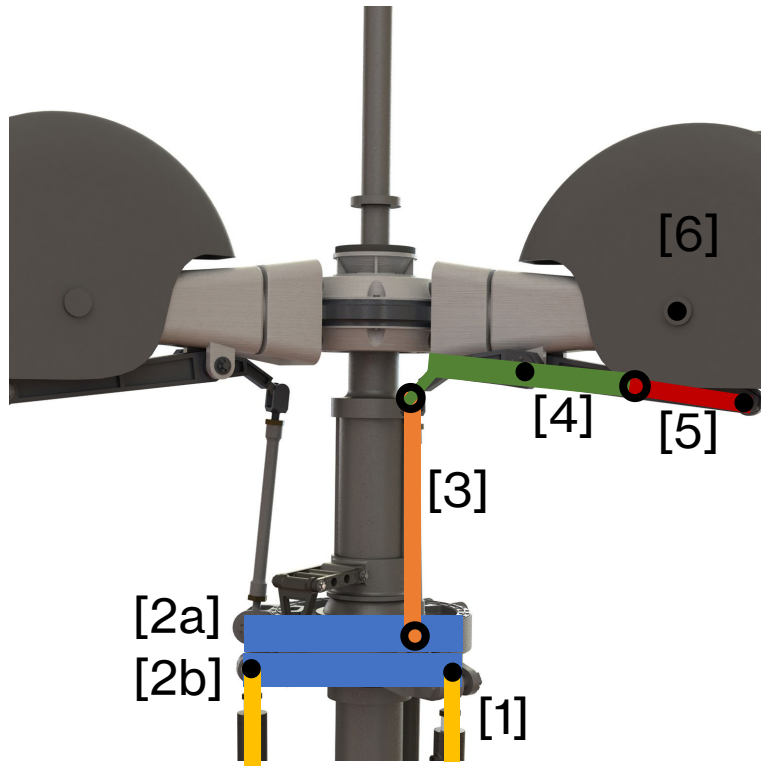

1. Swashplate actuators [1] extend
2. Swashplates [2a,b] elevate pitch links
3. Pitch links [3] rotate fold cranks [4]
4. Fold cranks pull on fold links [5]
5. Blades [6] rotate into folded position



Rotor Aerodynamics

- 3 - Bladed Rotor System
- Started Using Onera-OA-213 airfoil for root (3 ft chord length)
- Modified Thickness to fit spar and handle stress
- High Tip Speed Required Unique Tip Airfoil
- Tip airfoil: Boeing Vertol V-12 Airfoil (2.1 ft chord length)
- Disk Loading: 26 lbs/ft² (1.2 kN/m²)
- Induced Velocity: 50 mph (80 kph)
- Solidity: 0.144
- Speed Before Tilt: 123 knots
- Mach in Cruise: 0.6
- Hover Figure of Merit: 0.72

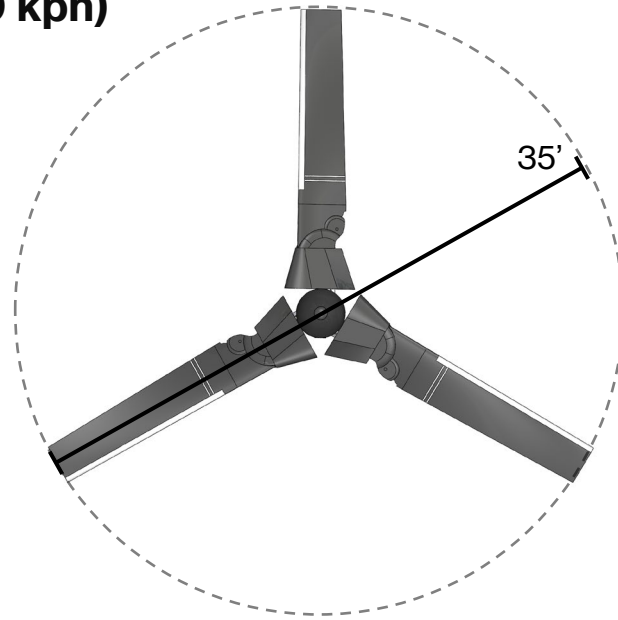

Top view of Rotor System in Hover

14% thickness 3.3 % camber

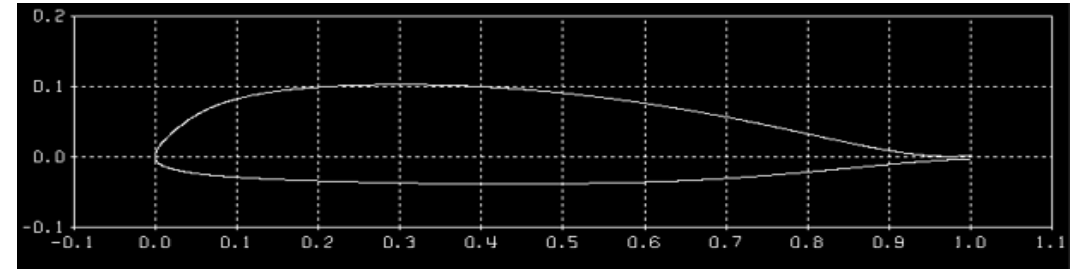

Root Airfoil: Onera-OA-213 Modified

10% thickness 2.2 % camber

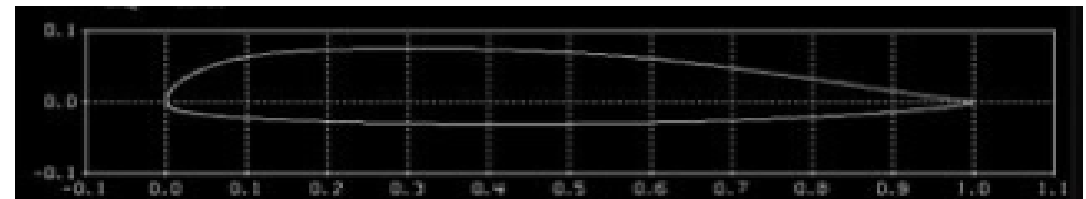

Tip Airfoil: Boeing Vertol V-12

Rotor Blade Structures: Employing Coning Flexure to Reduce Weight and In

Tantalum L.E. Weight Balance Tube
 - Move CG Forward Near 1/4 chord

Honeycomb structure
 - Prevent Planar Deformation of an Airfoil Due to Out of Plane Load

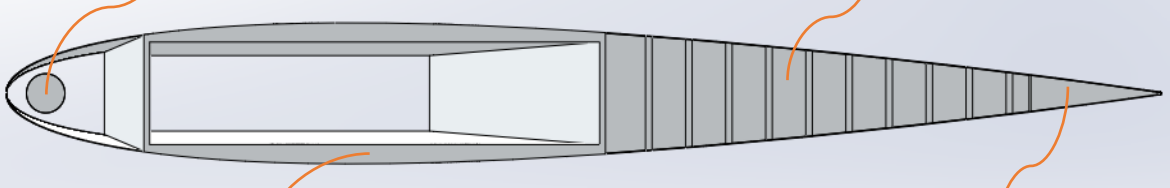

Quasi Isotropic Carbon/Epoxy Spar
 - Withstand Centrifugal and Lift load

T.E. Wedge
 - Bond Upper and Lower Airfoil

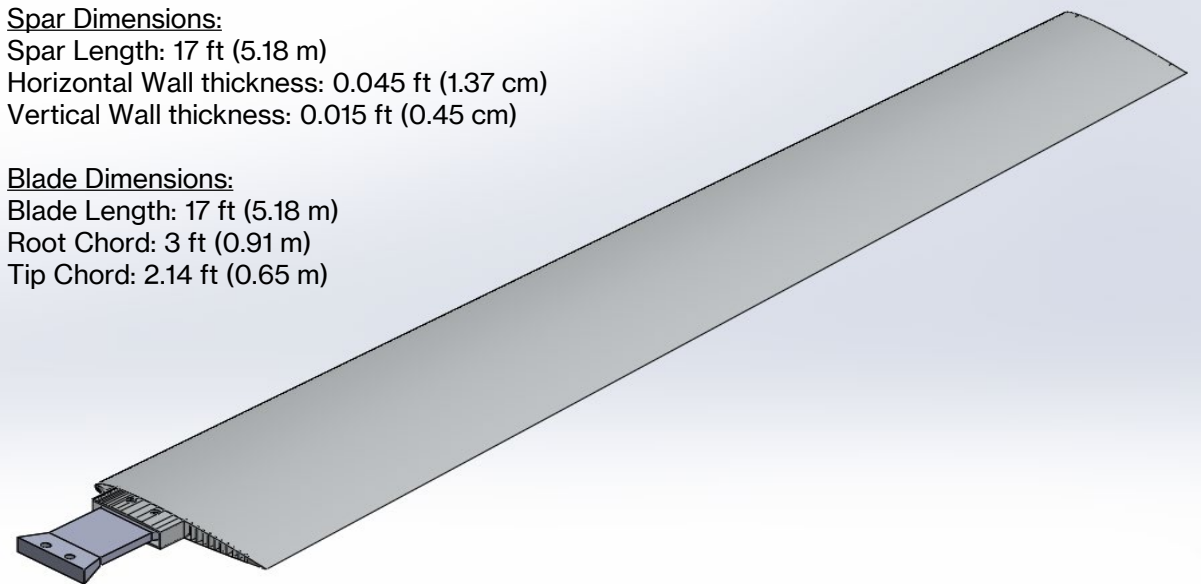

Spar Dimensions:
 Spar Length: 17 ft (5.18 m)
 Horizontal Wall thickness: 0.045 ft (1.37 cm)
 Vertical Wall thickness: 0.015 ft (0.45 cm)

Blade Dimensions:
 Blade Length: 17 ft (5.18 m)
 Root Chord: 3 ft (0.91 m)
 Tip Chord: 2.14 ft (0.65 m)

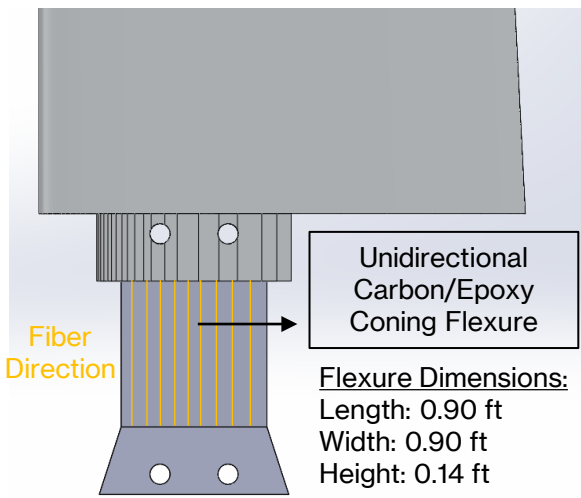
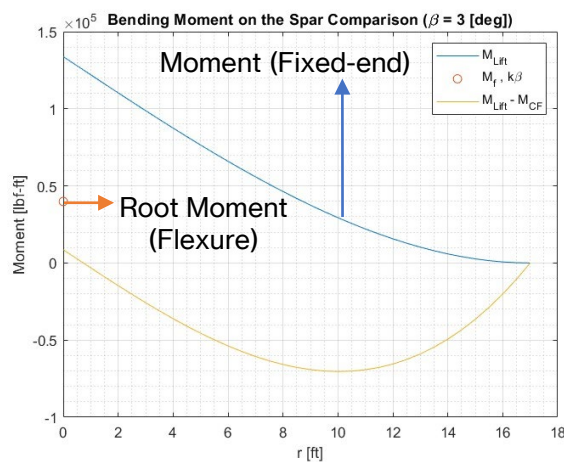

Unidirectional Carbon/Epoxy Coning Flexure

Flexure Dimensions:
 Length: 0.90 ft
 Width: 0.90 ft
 Height: 0.14 ft

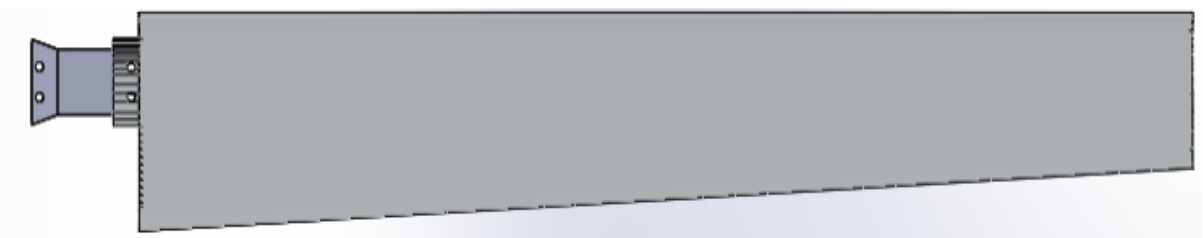

Flexure Purpose:
 1) Lower Bending Moment at the root
 2) Lower Total Stress
 3) Lower Weight (~70% reduction)

Propulsion System: Off-the-Shelf Engines

Rolls-Royce T406 Turboshaft Engine

- Weight: 971 lbs
- Max Power: 6150 SHP
- SFC: 0.426 lb/(SHP*hr)
- Length: 78.1 in
- Diameter: 34.2 in
- Number used: 2

Rolls-Royce BR725 Turbofan Engine

- Weight: 3,600 lbs
- Max Thrust: 16,900 lbf
- TSFC: 0.54 lb/(lbf*hr)
- Length: 130 in
- Diameter: 50 in
- Number used: 2

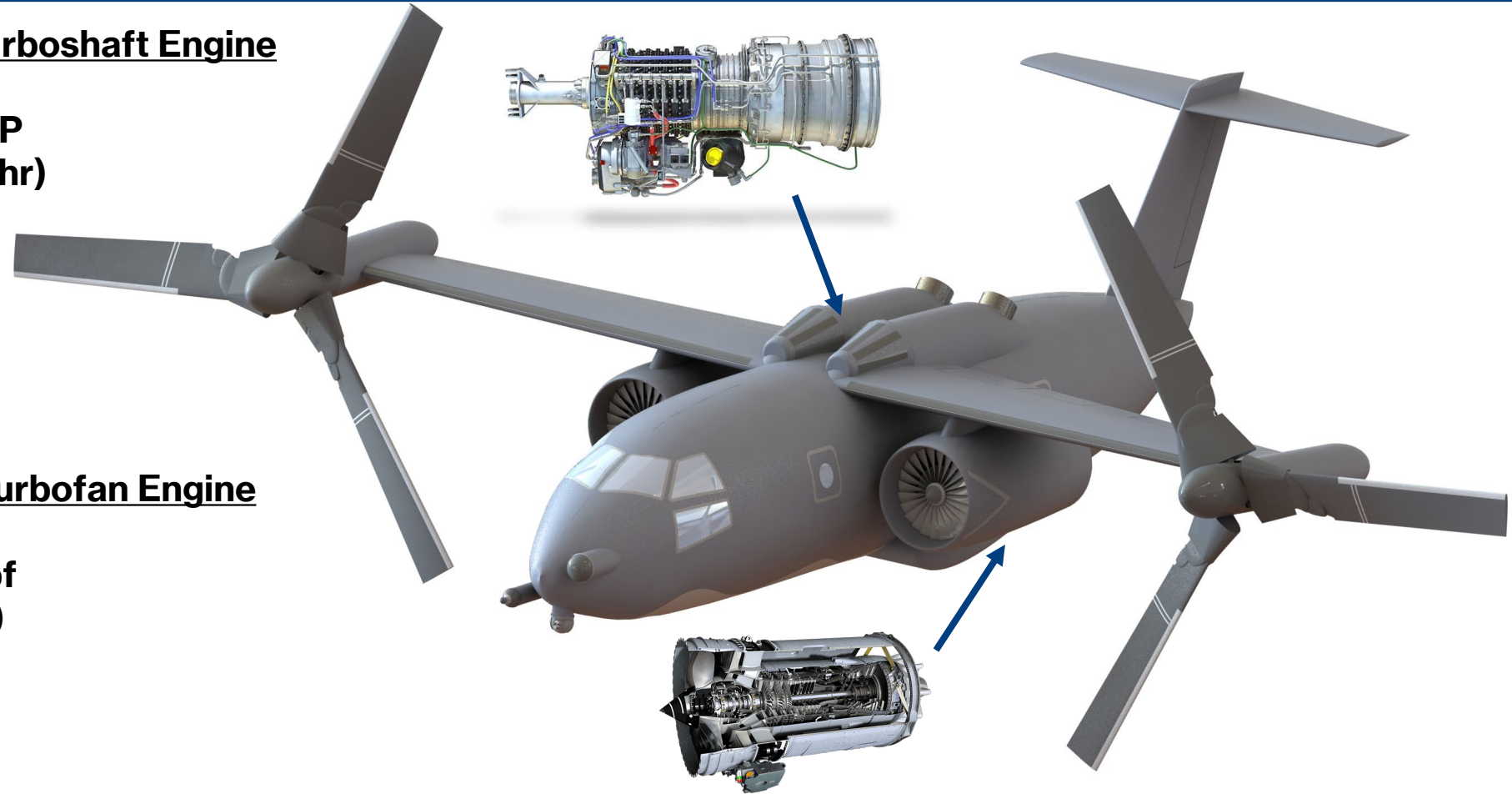

Use of COTS Engines reduces development cost, time, and risk



PennState

NIGHT FURY →

Powertrain System for Redundant Hover Performance

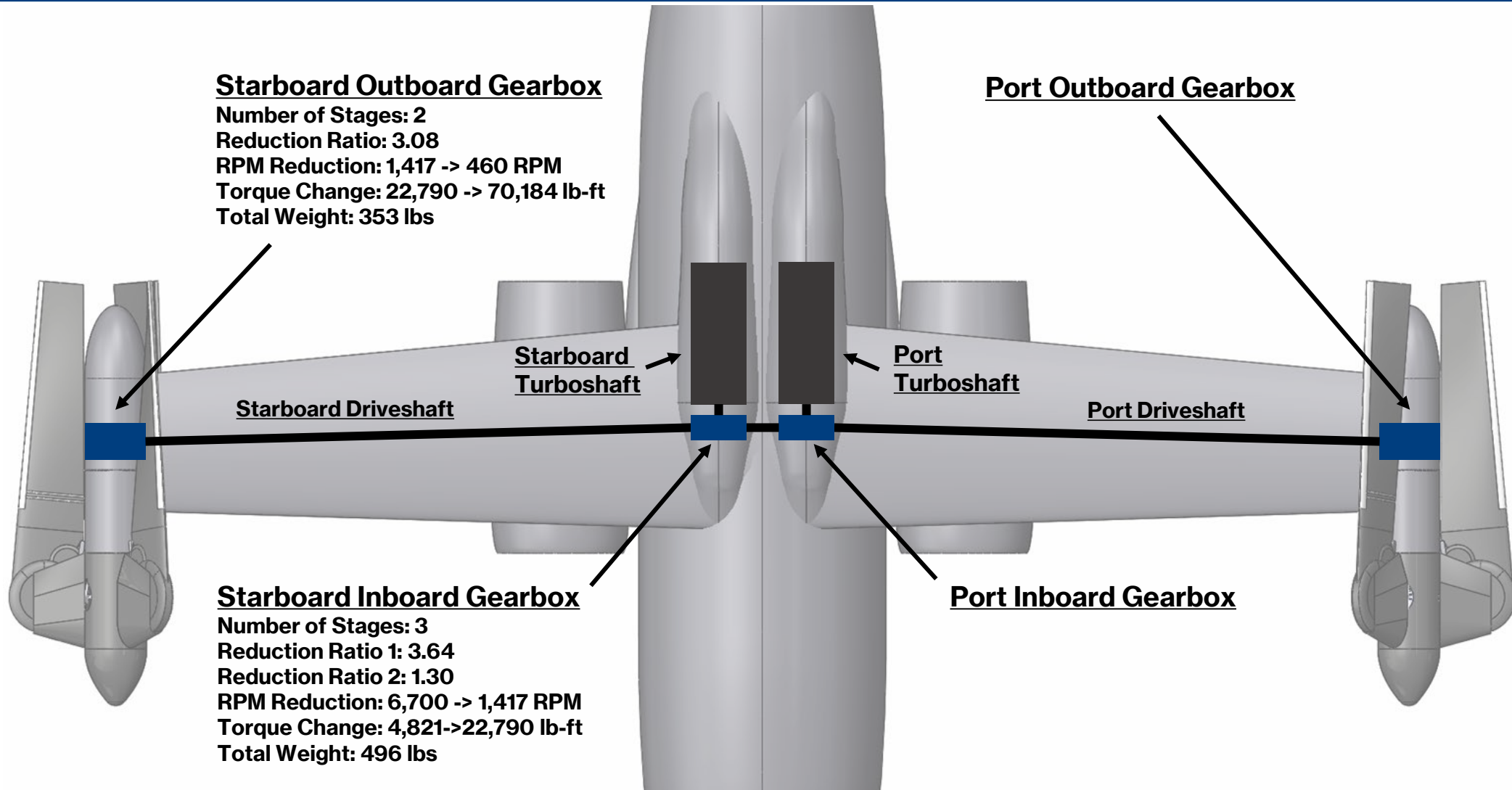

Stability and Control

Final Tail Size

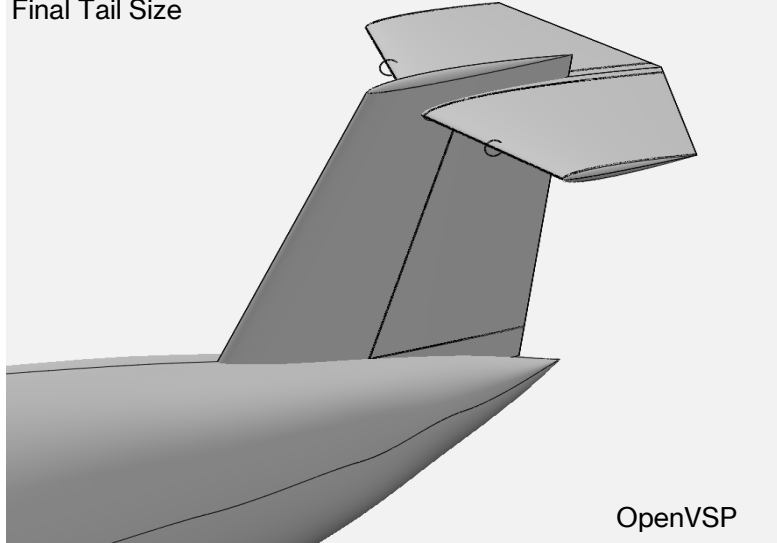

- Center of Gravity limits as percentage of MAC: 32%-44%
- Length between wing aerodynamic center and horizontal tail aerodynamic center: 37.2 ft
- Length Between Aircraft Center of Gravity and Vertical Tail Aerodynamic Center: 33.3 feet
- Area of horizontal tail: 97.8 ft²
- Area of vertical tail: 67.8 ft²

Longitudinal Trim

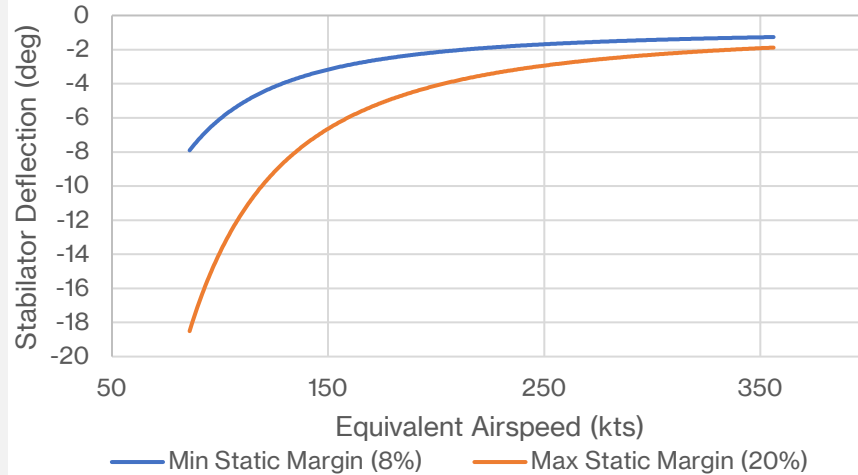

Elevator: All flying tail/stabilator

Trim Deflection (TE up)	SM_min 8%	SM_max 20%
Stall (118 KTAS)	7.9°	18.5°
Cruise (450 KTAS)	1.3°	2.1°

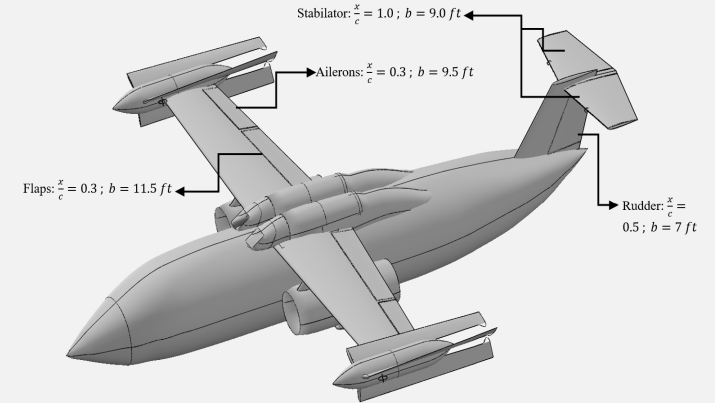

Center of Gravity Limits
32%-44% of Mean Aerodynamic Chord

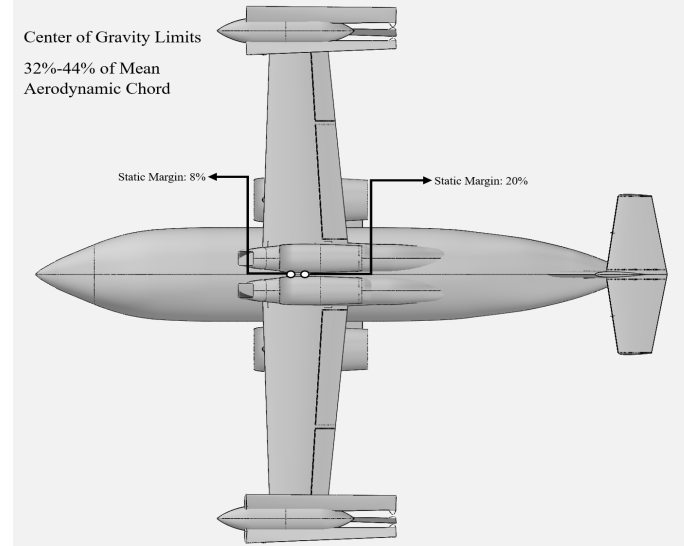

Cockpit Layout and Equipment Selection Maximizes Pilots Situational Awareness in Highly Contested Environments

Item	Model Designation
Intercom System	AIC-25
UHF Comm.	ARC-150
UHF DF horning	705CA
Air-to-ground IFF	APX-92
TACAN	ARN-100
ILS-VOR	RCS-AVN-220
Gyrocompass	ASN-89
Internal Nav Syst	LN-30
High-freq Radio	ARC-123
Autopilot System	-----
Air data Comp	AXC-710
Radar	APR-41
Countermeasures	ALE-28
Countermeasures	ALR-23
Radar Altimeter	APN-167
Terrain Radar	APQ-110
Flight Data Rec	-----

Equipment Used

Equipment selected to ensure that the pilots can safely navigate contested environments

3 large windows spanning to the floor for increased pilot visibility in all directions while leaving room between them for structural support

Multifunctional display for pilots to view any data needed while flying

Floor placed low enough to allow windows to curve in for increased vertical visibility

Placement of cyclic and collective sticks

Center console to avoid interference with the pilot's visibility

Pilot and co-pilot seats

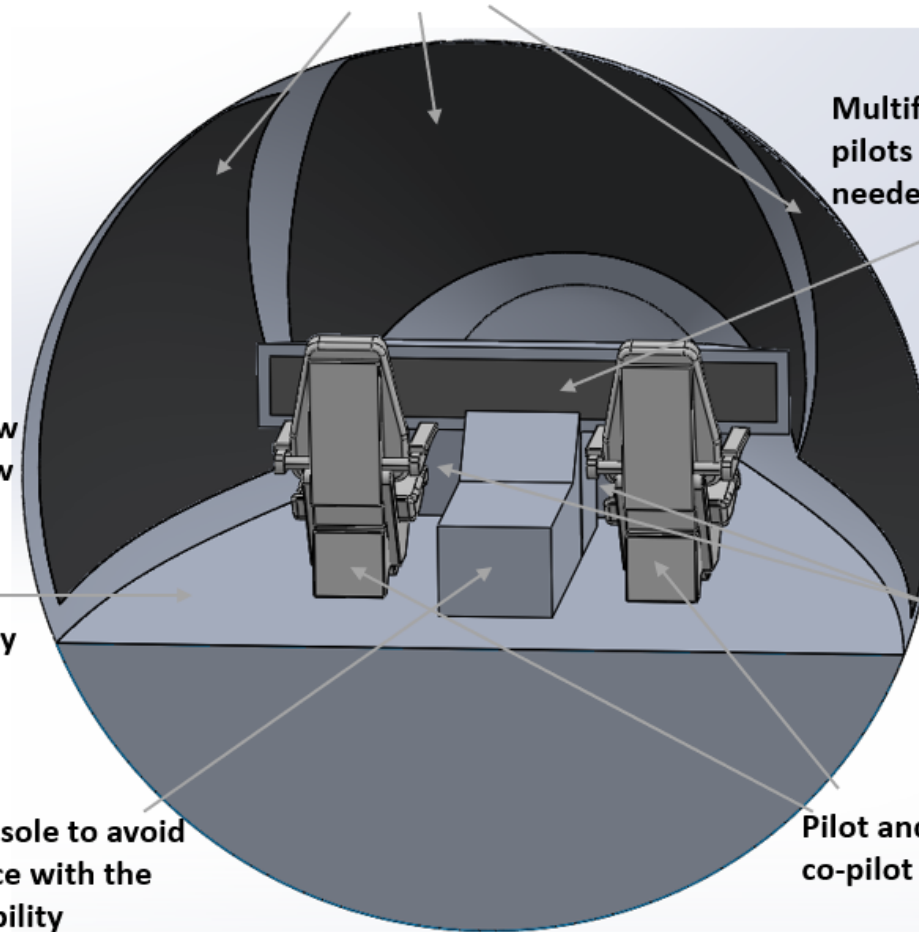

Interior Cockpit Layout

NIGHT FURY 



PennState

HSVTOL Functionality with High Technology Readiness Level

Night Fury Unit Cost

\$110.5 M

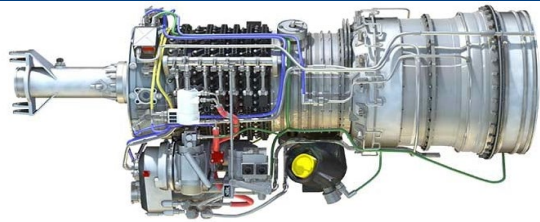
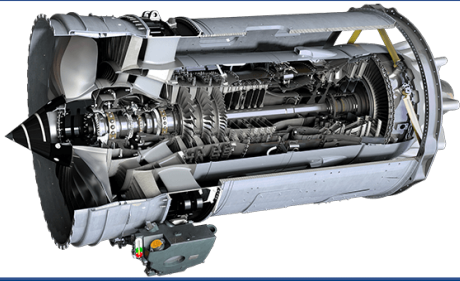

**COTS Engines:
Reduces R&D Cost
and Increases TRL**

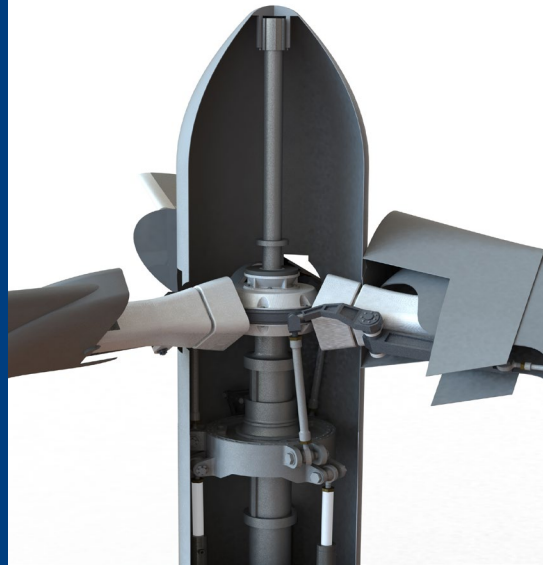

**Mechanism Based on
Existing Research**

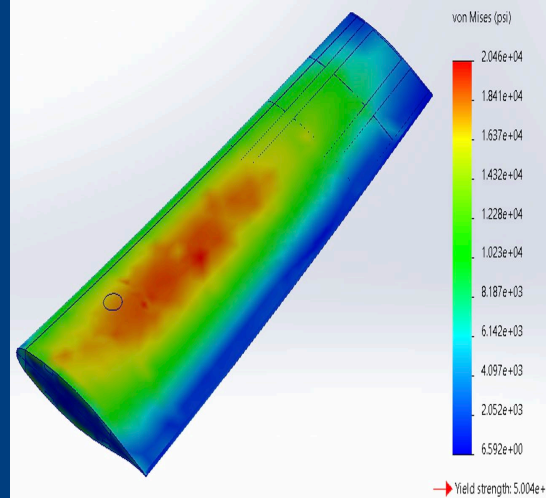

**Cost Effective and
Durable Aluminum
Wing and Airframe**



**Leverages Existing
and Proven Tiltrotor
Technologies to
Lower Risk**

Summary

2x T406 Turboshafts

- Surplus power for redundancy
- High-mounted to eliminate exhaust hazards

Folding Tiltrotor Mechanism

- Open rotor system with minimal drag in cruise
- Low downwash in hover
- Custom-designed rotor structure

Custom Airfoil: SC-14 Night Blade

- Optimizes lift while minimizing transonic drag

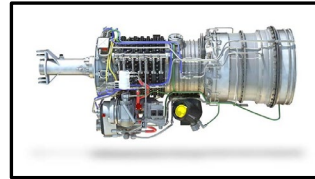
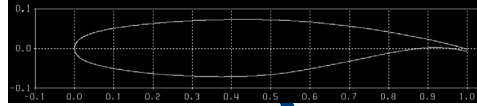

Pressurized Fuselage

- Maximizes volume
- High-altitude operation

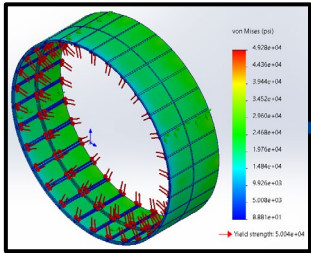

Rear Cargo Ramp

- Facilitates ingress and egress

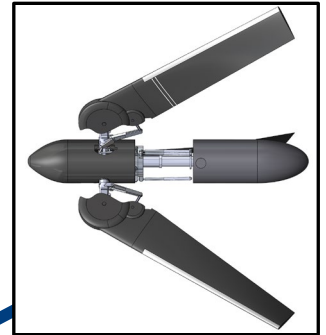

2x BR725 Turbofans

- Efficient, small, and powerful
- COTS hardware minimizes risk and cost

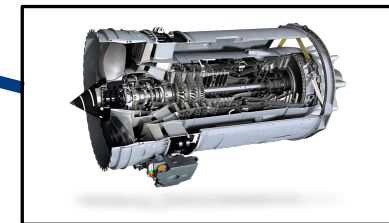

Sensors and Avionics

- Increases awareness and survivability in contested airspace

High-Visibility Cockpit

- Improves pilot SA in low-altitude environments

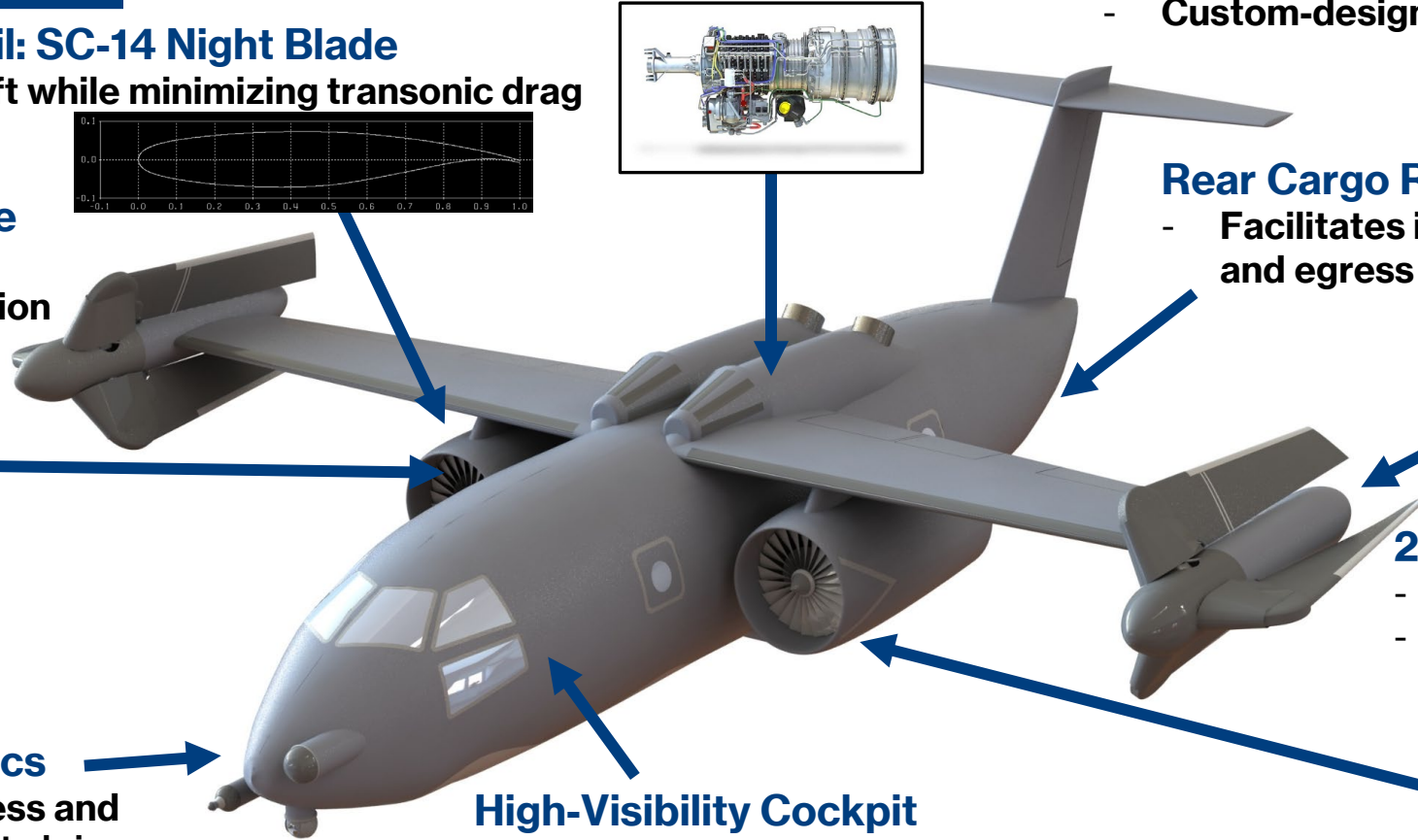

The *Night Fury* HSVTOL concept, designed by students at Penn State, is optimized for performing and exceeding expectations in both hover and cruise. Using a folding tiltrotor configuration, both low downwash in vertical flight and low drag in forward flight can be attained. By combining novel technologies with proven designs, the Penn State team offers a future vertical lift solution without compromise and without comparison.