

 Poli'sCrew

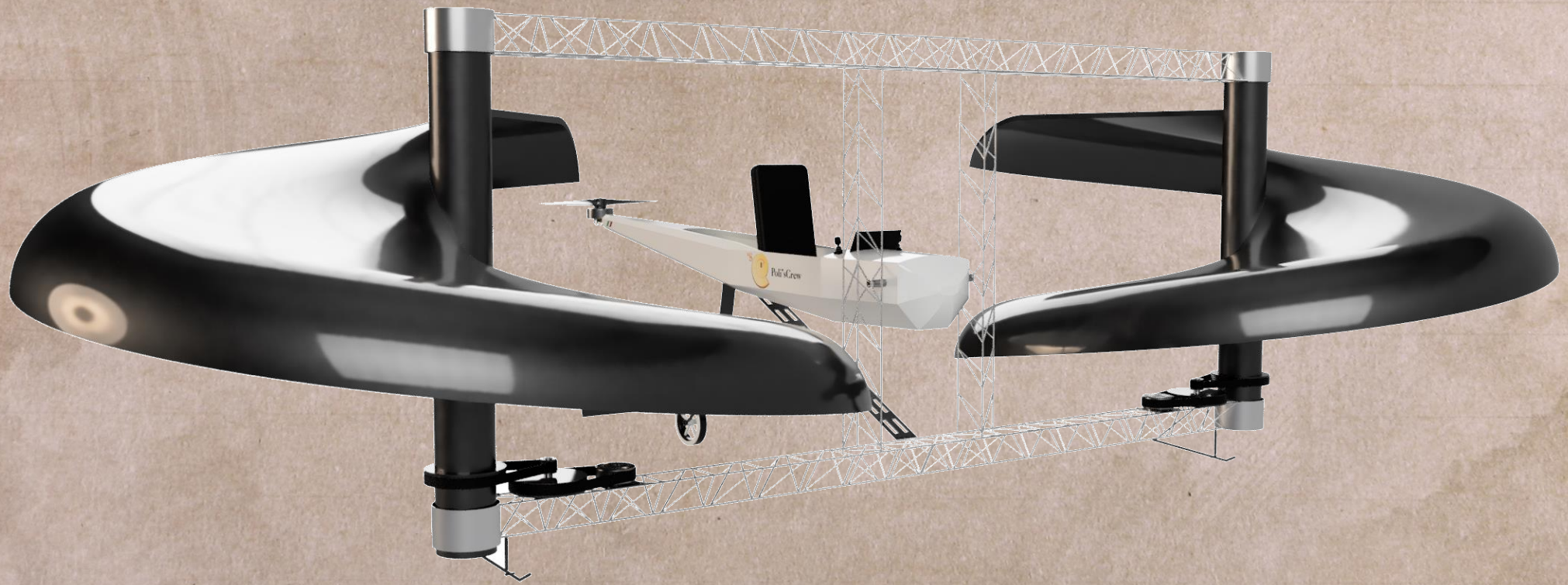



Gianni Curti

Undergraduate student

gianni.curti@mail.polimi.it

Alberto Chiozzi

Undergraduate student

alberto1.chiozzi@mail.polimi.it

Giuseppe Di Stasi

Undergraduate student

giuseppe.distasi@mail.polimi.it

Luca Colombo

Undergraduate student

luca56.colombo@mail.polimi.it

Edoardo Chisalè

Undergraduate student

edoardo.chisale@mail.polimi.it

Matteo Di Pilato

Undergraduate student

matteo.dipilato@mail.polimi.it

Giuseppe Quaranta

Faculty advisor

giuseppe.quaranta@polimi.it



Introduction

This document contains the Poli'Screw team response to the Vertical Flight Society 37th Annual student design competition, sponsored by Leonardo Helicopters.

500 years later his death the team tried to study the physics and the possibility of replacing the nowadays' rotors with one or more aerial screws like that one designed by Vinci's genius centuries ago.

The result is an aircraft capable of widely exceeding the minimal requests of the competition by demonstrating a high endurance in forward flight, a climb rate that allows it to overcome the most of the obstacles in an urban environment in short times and a good maneuverability capability around the three axes.



Aereal Screw

Generate lift, the internal structure is made of high modulus carbon fiber and covered with spinnaker.

Central Structure

Made of alluminium 7075, it serves to connects the two aereal screws and the fuselage.

Engine

The aircraft is powered by three electric motors (Emrax 188).

Fuselage

It is made of carbon fiber, it houses the pilot, the battery packages and the tail rotor for the rear propeller.

Rear Propeller

It has two two degrees of freedom. It is used to control the yaw and the pitch axes.

Landing Gear

Is composed by two skates in the front and a leg with a wheel in the back.

Trasmission

It is made of belts and pulleys. It server to adjust the number of the RPM

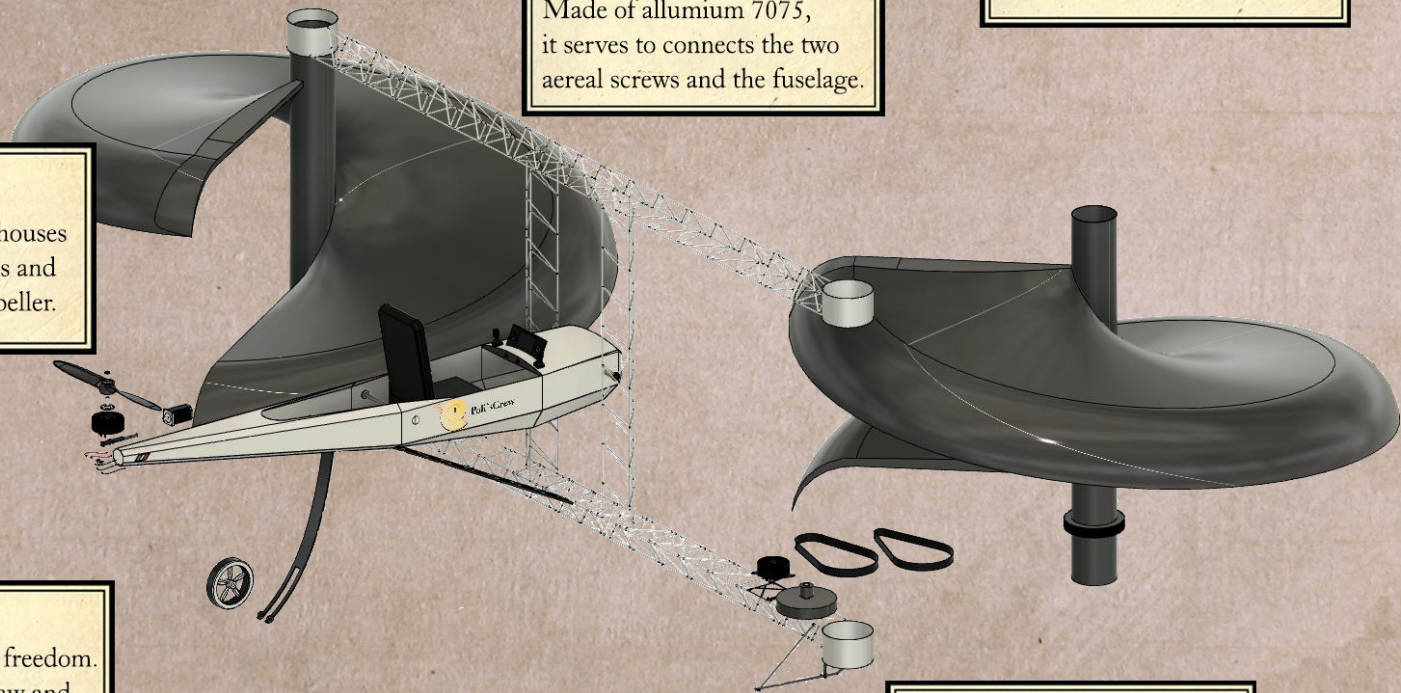



Basic Mission

The aircraft must:

- Carry 1 pilot of 60 kg;
- Take-off vertically, holding the position for at least 5 seconds;
- Flying for at least one minute, covering 20 m of distance at an altitude above the ground of 1 meter;
- Land vertically and hold the position for 5 seconds;

Advanced Mission

Our aircraft can:

- Take-off vertically reaching a height of 5 meters in 10 seconds (climb rate = 0.5 m/s).
- Fly for a maximum time in horizontal translation at constant speed of 640 seconds with a peak speed of 10 m/s;
- Cover a maximum distance of 6,4 km.

Tail Propeller and Forward Movement

At the end of tail, we placed a rotor that produce 25% of the total thrust. It mainly servers to support the aircraft in hovering, balance the yaw axes total moment with respect to the center of mass and generate the pitching torque to bring the aircraft forward.

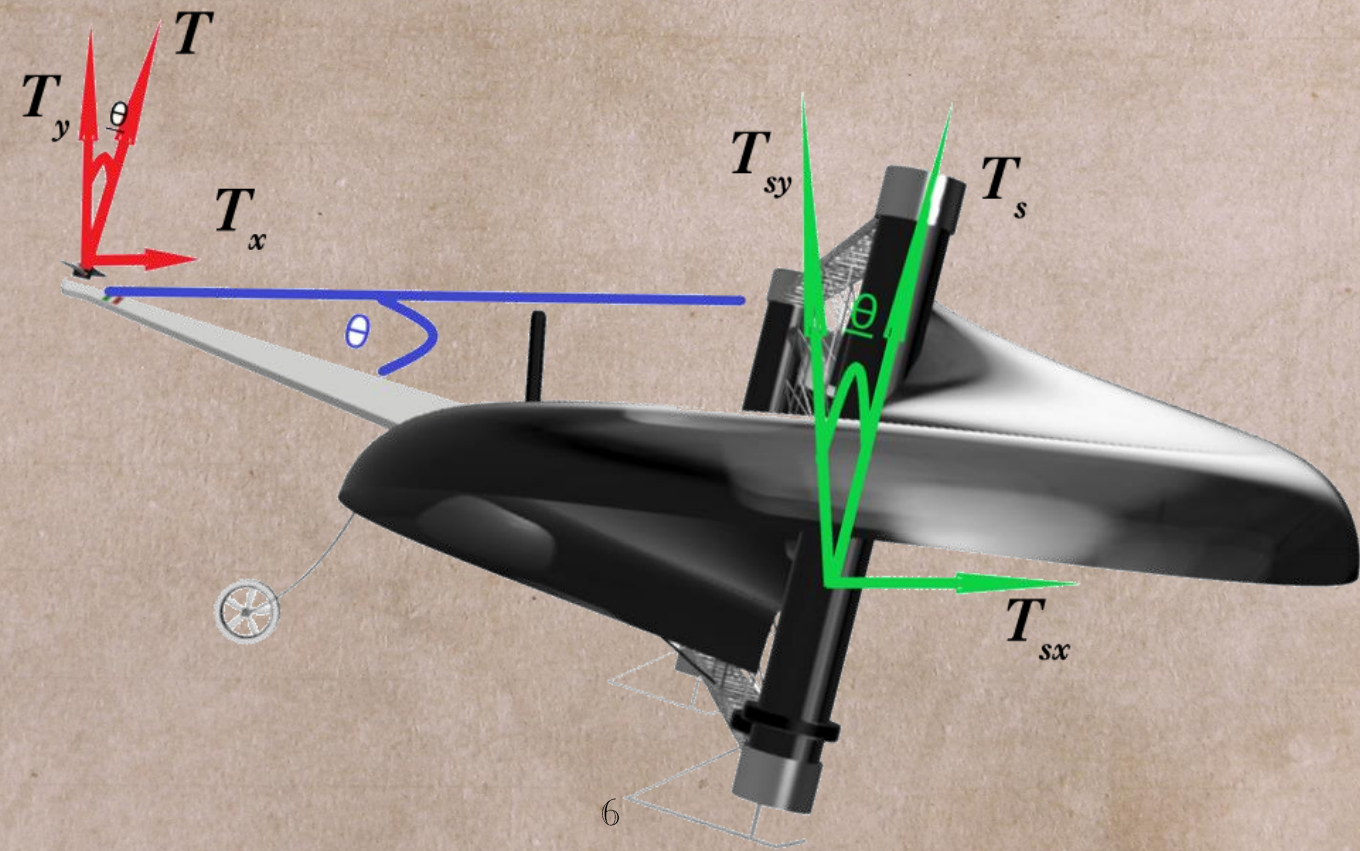



Structures

The center of gravity is perfectly aligned with the rotation axis thanks to the different ribs sizing so that the screw can move without suffering big vibrational events.

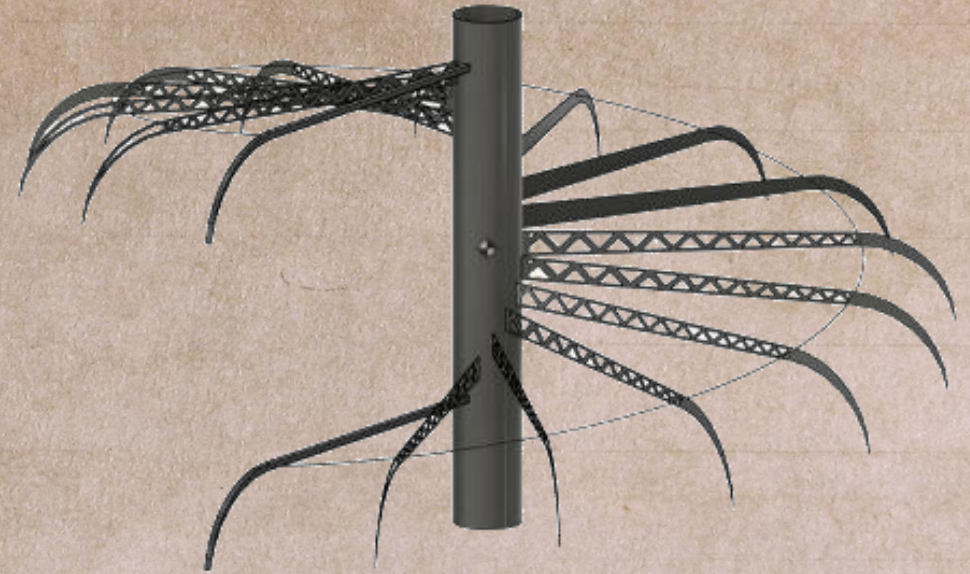
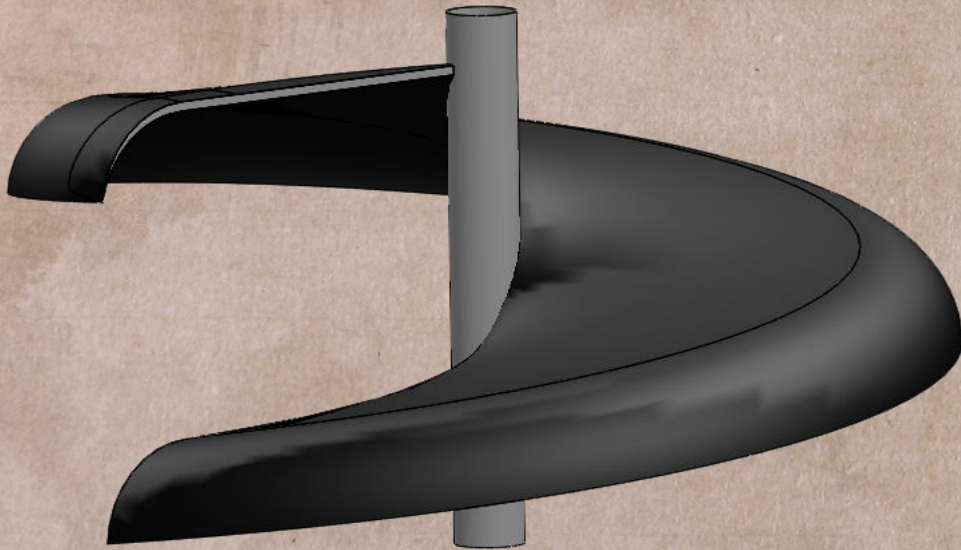

The screw coverage is made by a special sail fabric, the Spinnaker. It is a light high resistant material perfect to withstand to all the stresses that happens during the mission and unload them on the bellowing ribs.

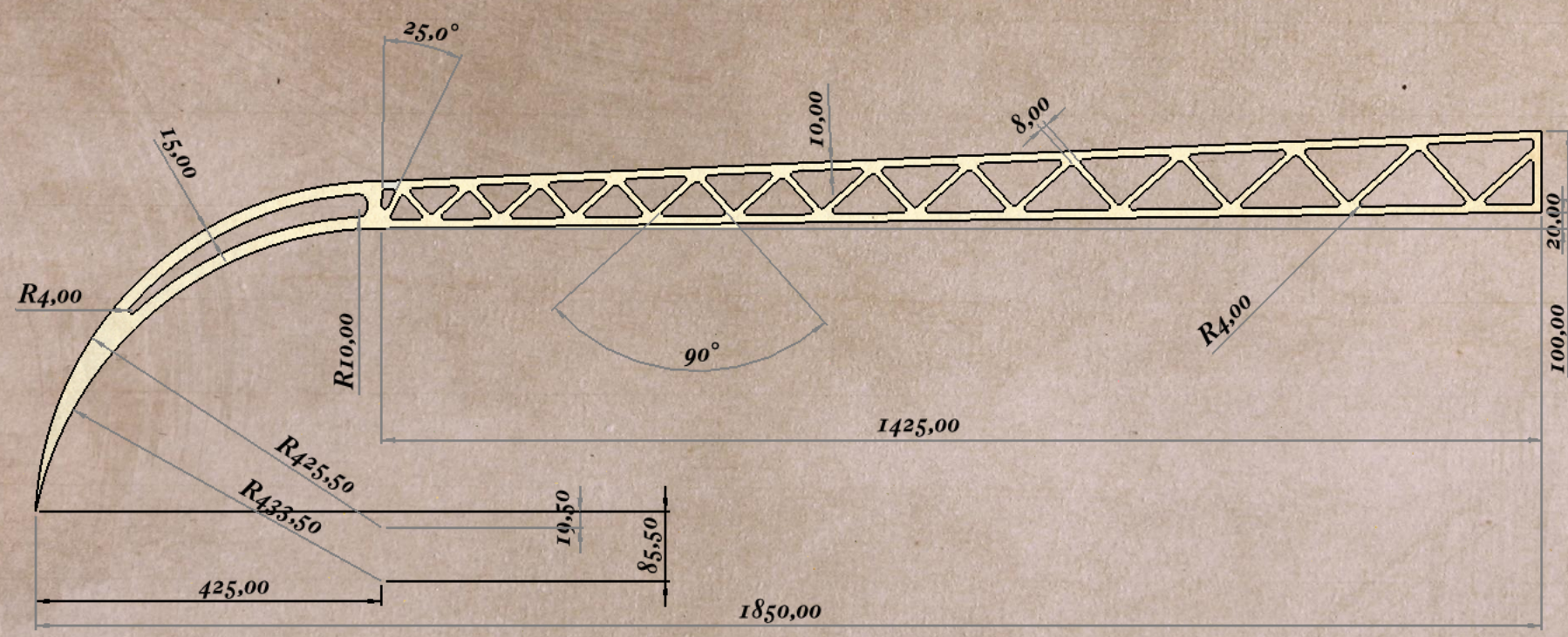

All the measure in the figure are in millimeters

The structure of each rib has been optimized with different characteristics depending on their position in order to minimalize deformation and weight. The final weight is of 24.1 kg.



All the edges have been rounded because sharp junctions are points where fatigue can take place after several using cycles.

One of the main goal to the screw structure was to reduce the first rib height. The first rib, when hit the air, caused the creation of big vortices resulting in a high loss of usable energy.

We so opted for a circular section rib that could better resist to lateral forces.

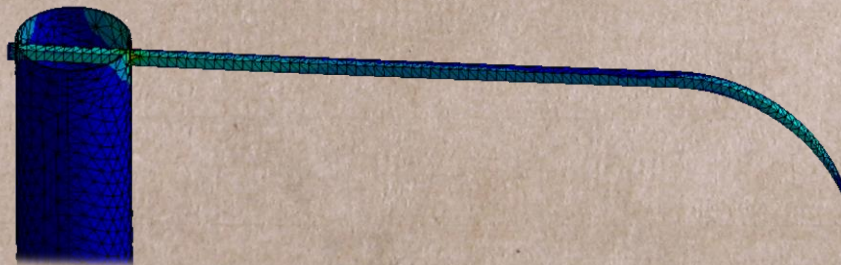
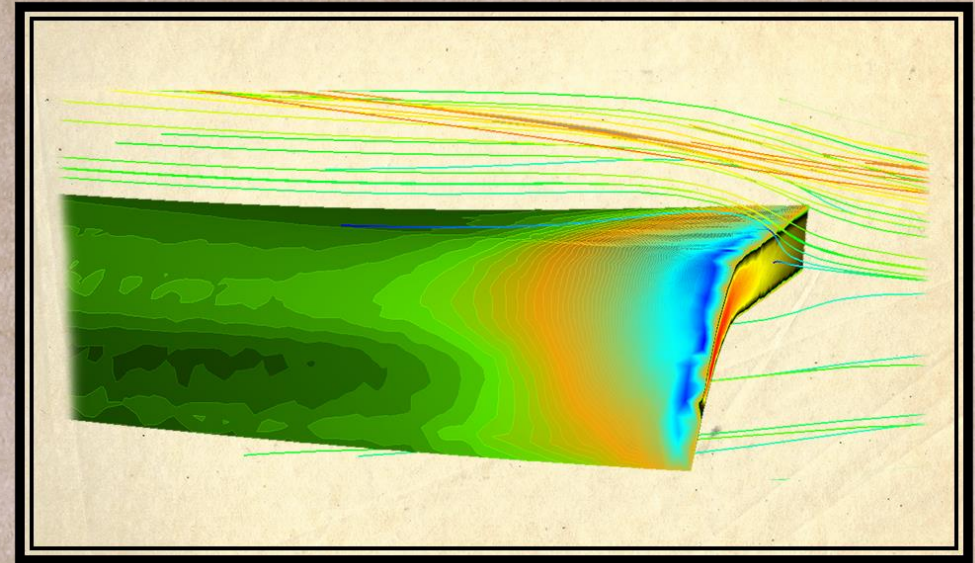

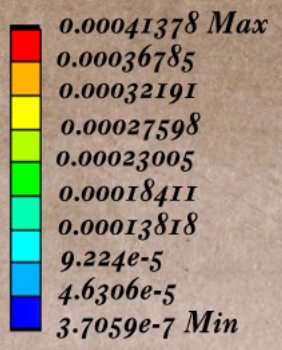
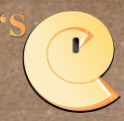

As you can see in the figure the strain is very small even if the upper and bottom tube are very tiny in thickness. We considered a safety factor of 1.5 on the worst mission condition.

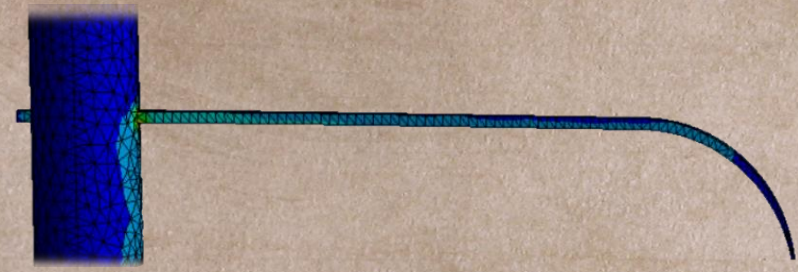



Main Structure

The horizontal structures are made by three main bars each of 5m. The three bars are arranged in a triangular configuration at 200 mm to each other.

This structure is made from aluminum 7075 and weighs 23.61 kg.

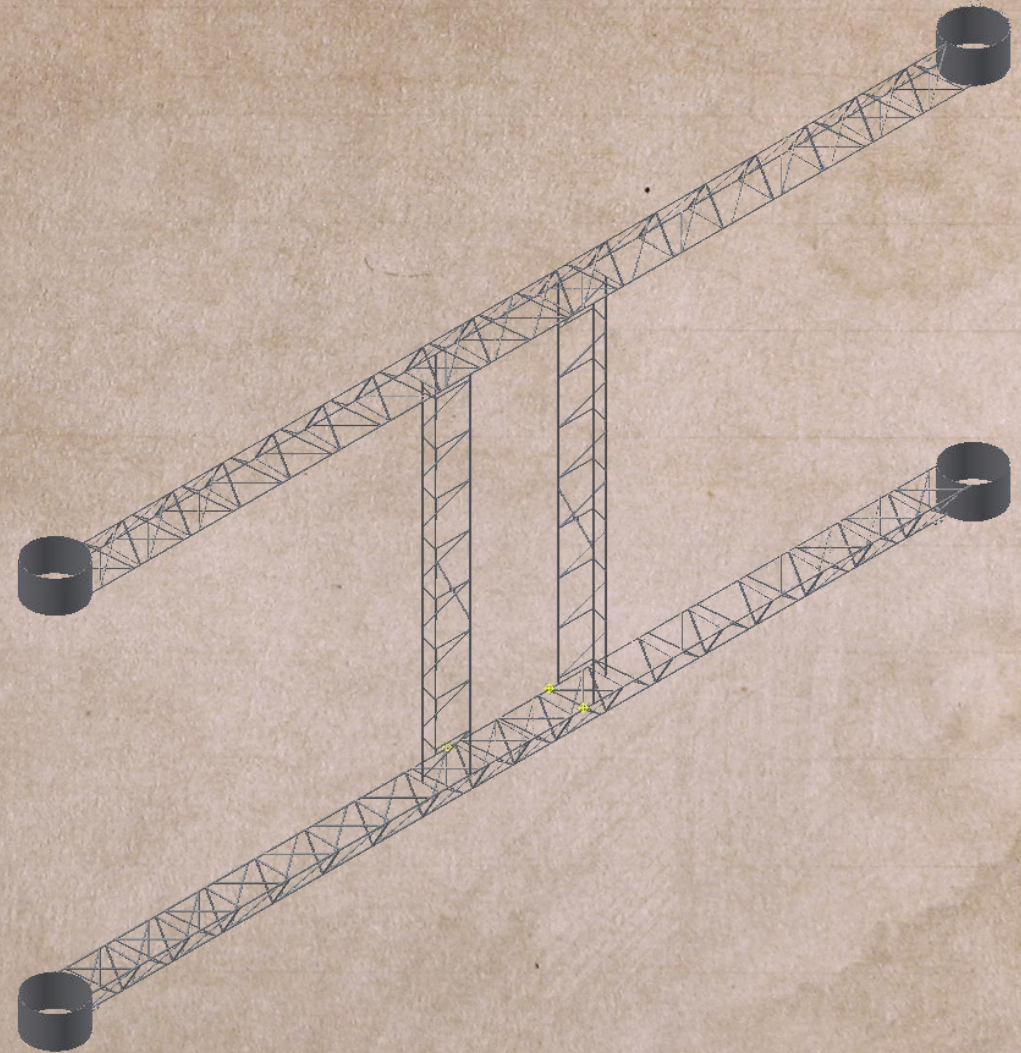

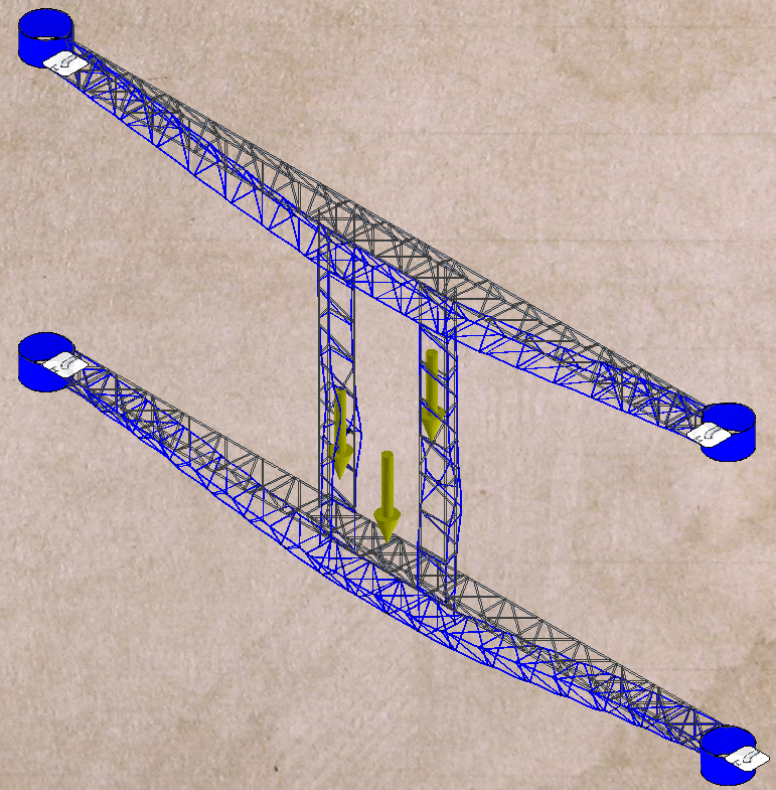
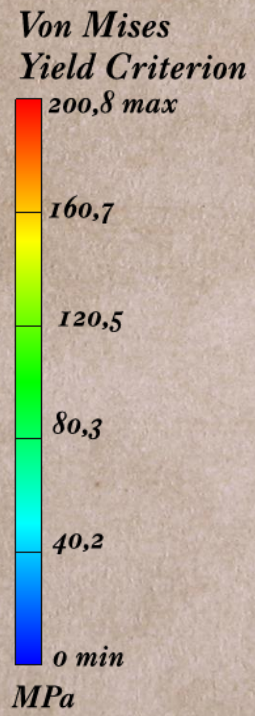
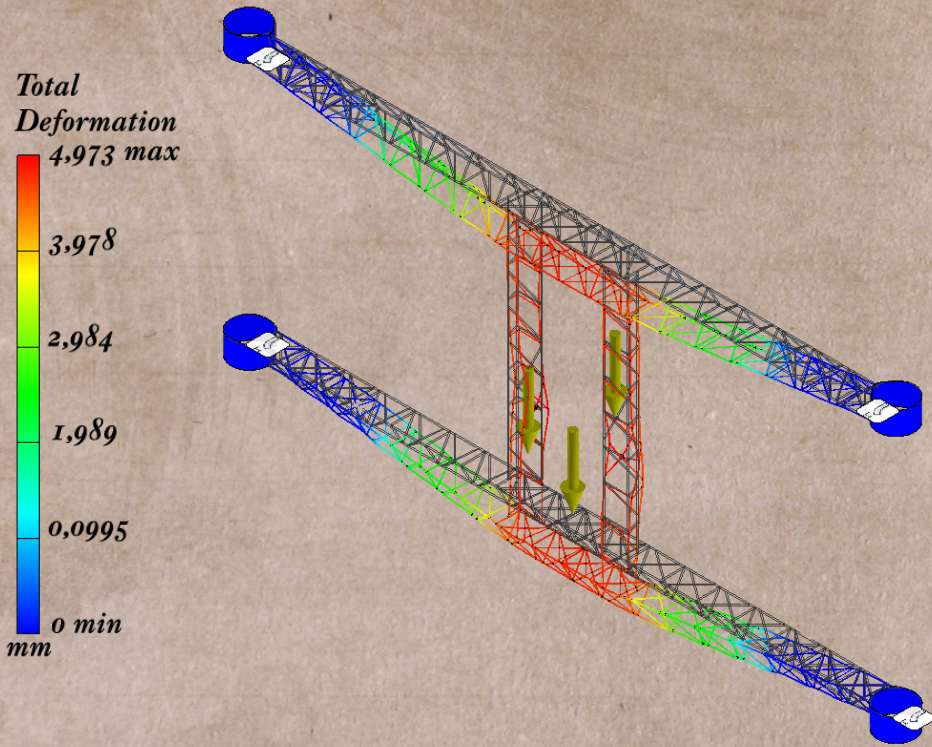



Propulsion and power

Li-ion batteries are connected in series to a control circuit in order to grant a correct recharge.

Each package contains 4 batteries for a total of 12 V of discharge tension.

In order to meet the requirements of the inverter 10 packages were connected in series.

For each motor, the total charge is 28 Ah.

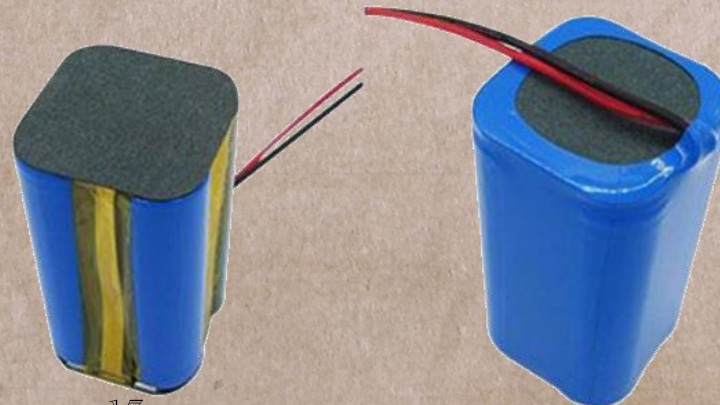
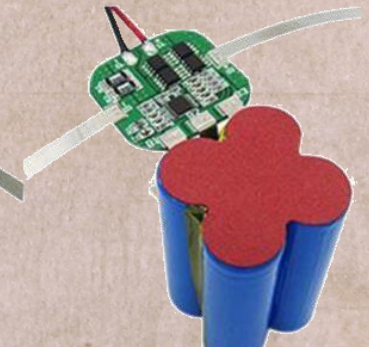
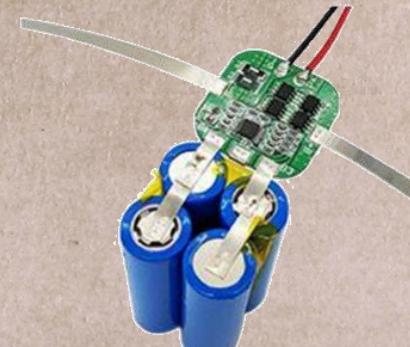
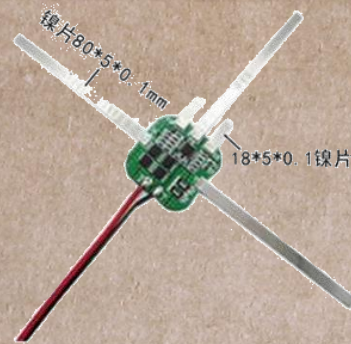

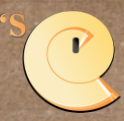

The batteries (2.5 kg) were positioned behind the pilot, in order to grant the correct balancing of momentums.

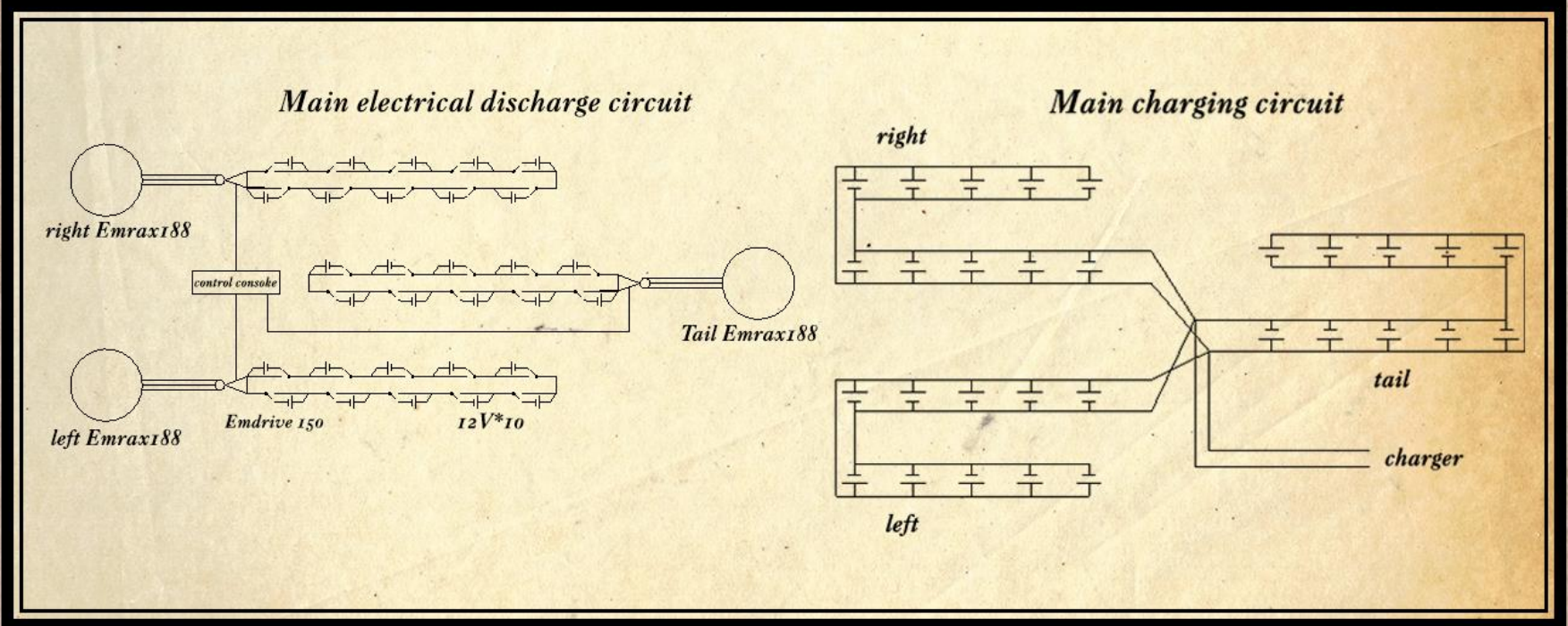
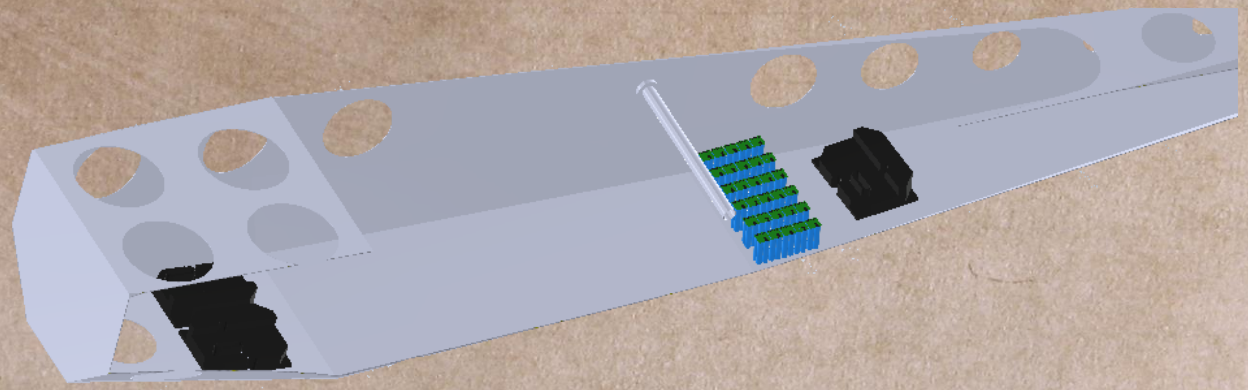



For the propulsion, we chose a Emrax188 MV AC. The power and lightness (only 7 kg) of this motor fit just perfect for our aircraft. By using an electric powered motor, we could give the vehicle more stability and ease of control.

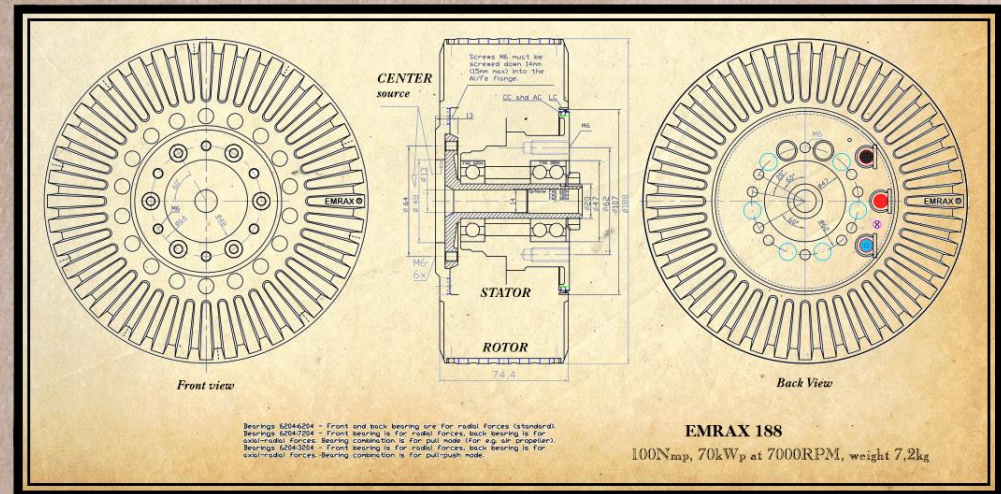
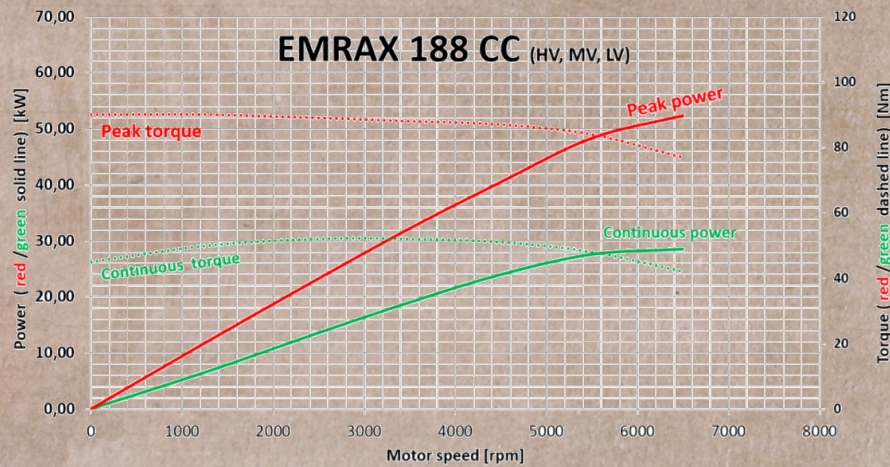



In order to control the speed and power generated by the motor we chose the inverter Emsiso emDrive 150_300/120 that has a continuous power of 21 kVA. Its weight is 1.7 kg.

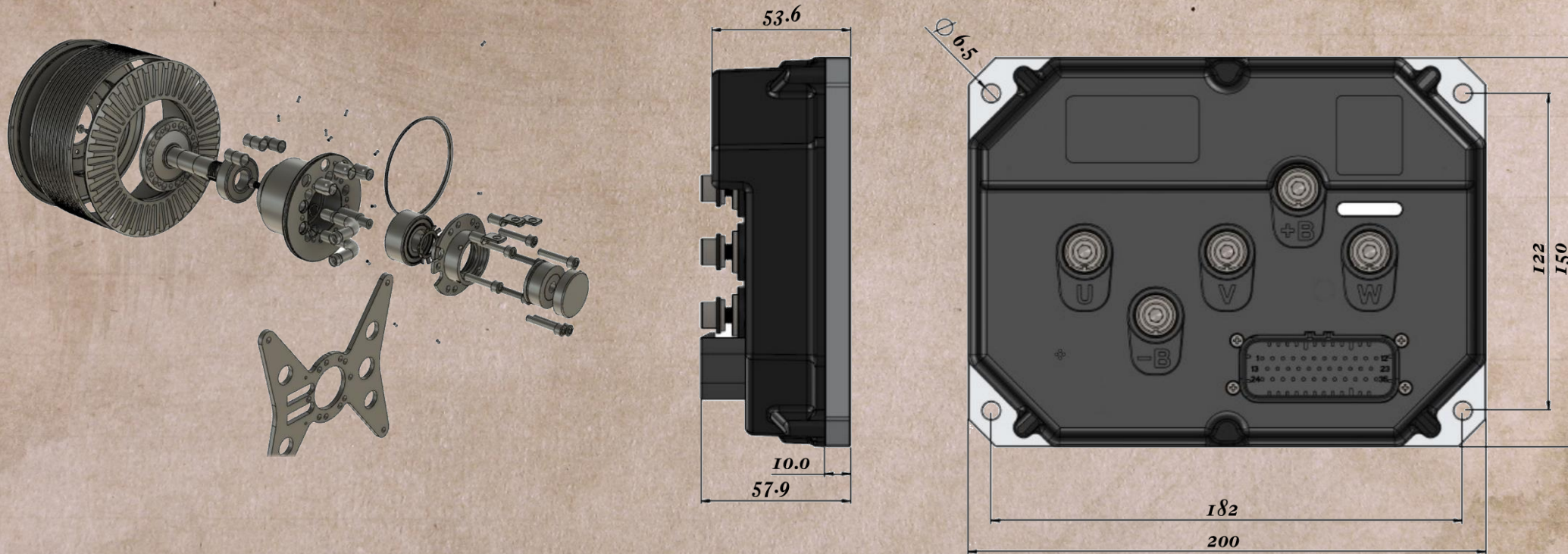



Battery Safety System

In order to reduce risks to the pilot, we wrote an Arduino program which automatically manages to exclude broken batteries from the system. This made possible to land with only 20% of the total batteries available. We put a lot of effort in order to protect and make the ride enjoyable to the pilot.

```
6 void setup() {
7   pinMode(buttonpin, INPUT_PULLUP);
8   pinMode(ledpin, OUTPUT);
9   pinMode(transistor [0]=4, OUTPUT);
10  pinMode(transistor [1]=5, OUTPUT);
11  pinMode(transistor [2]=6, OUTPUT);
12  pinMode(transistor [3]=7, OUTPUT);
13  pinMode(transistor [4]=8, OUTPUT);
14  pinMode(transistor [5]=9, OUTPUT);
15  pinMode(transistor [6]=10, OUTPUT);
16  pinMode(transistor [7]=11, OUTPUT);
17  pinMode(transistor [8]=12, OUTPUT);
18  pinMode(transistor [9]=13, OUTPUT);

19  pinMode(testpin [0]=0, INPUT);
20  pinMode(testpin [1]=1, INPUT);
21  pinMode(testpin [2]=2, INPUT);
22  pinMode(testpin [3]=3, INPUT);
23  pinMode(testpin [4]=4, INPUT);
24  pinMode(testpin [5]=5, INPUT);
25  pinMode(testpin [6]=6, INPUT);
26  pinMode(testpin [7]=7, INPUT);
27  pinMode(testpin [8]=8, INPUT);
28  pinMode(testpin [9]=9, INPUT);
```

```
37 void loop() {
38   if(digitalRead(buttonpin)==LOW)
39   {
40
41     for(k=0;k<10;k++)
42       if(analogRead(testpin [k])==LOW)
43       { digitalWrite(ledpin, HIGH);
44         digitalWrite(transistor [k], HIGH);
```

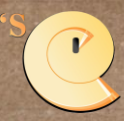

Transmission Ration

We decided to use a belt transmission for its simplicity and low weight. From the results obtained from the studies of our engines and inverter, a mechanical transmission ratio of 1:9 was necessary. As a direct scaling was not realistically possible for a belt transmission, we decided to choose a double pulley system. The rotor of the Emrax engine is 0.09m in radius, the shaft pulley of the rotor is 0.18m in radius. The pulley dimension are $r1 = r1 = r3 = 0.18m$ and $r2 = 0.04$.

