

A Critical Re-Examination of the Franklin Institute Rotating Wing Aircraft Meeting
of
October 28 – 29, 1938: Facts and Myths Surrounding the Foundations of
Autogiro/Convertiplane/Helicopter Development in America and Europe

Dr. Bruce H. Charnov
Hofstra University
Hempstead, NY 11549-1340
mgbbhc@hofstra.edu

Abstract

The Rotating Wing Aircraft Meeting of October 28 – 29, 1938 at the Franklin Institute in Philadelphia, PA, sponsored by the Philadelphia Chapter of the Institute of the Aeronautical Sciences, was an historic gathering of those involved, committed to and researching Autogiro/convertiplane/helicopter flight. It was, as described in the Preface to the Conference Proceedings, “the first free discussion in this field of science open to all engineers in the aircraft industry.” This was a significant gathering for the future of rotary wing flight in America, coming at a time when the Autogiro movement was moribund and helicopter development was just about to receive a boost with commencement of the just-passed Dorsey-Logan Bill. And, perhaps of greater importance, those attending including many of the leading developers of rotary wing flight were actively speculating as to the future that such flight might take. Their speculations, now generally forgotten, would be vindicated within the decade to come, and their efforts subsequent to that initial rotary wing meeting shape that future. This first significant meeting dealing with rotary wing flight has been either unjustly forgotten or inaccurately mythologized, and only when examined, reclaims its historical importance and place in vertical flight history.¹

¹ Presented at the American Helicopter Society 62nd Annual Forum, Phoenix, AZ, May 9 – 11, 2006. Copyright © 2006 by the American Helicopter Society International, Inc. All Rights reserved.

The 1938 Meeting: Battlefield or Conspiracy?

The October 1938 Rotating Wing Aircraft Meeting at the Franklin Institute in Philadelphia has largely been relegated to obscurity in the almost-seven decades since those who would primarily fashion the emergence of the helicopter and advance rotary wing flight for the majority of the remaining years of the 20th century gathered to share information and exchange ideas. Only two major authors – Frank Kingston Smith in *Legacy of Wings: The Story of Harold F. Pitcairn*¹, which deals with the American Autogiro pioneer, and Jay P. Spenser in *Whirlybirds: A History of the U.S. Helicopter Pioneers*² discuss this meeting, and each, as discussed *infra* based on an analysis of the actual meeting presentations and comments, derives a seemingly biased view.³ Even those in attendance (and who made presentations), who were even then or about to play significant roles in helicopter development, fail to cite the 1938 meeting in their later biographical writings, most notably H. Franklin Gregory⁴ and W. Laurence LePage.⁵

Spenser describes that 1938 meeting in this manner:

“Late in 1938 and 1939, he [Igor Sikorsky] and other helicopter pioneers attended two *profoundly significant* symposia at Philadelphia’s venerable Franklin Institute.^[6] Organized by the Institute of Aeronautical Sciences – predecessor of today’s American Institute of Aeronautics and Astronautics – which cosponsored the events with the Franklin Institute, the now-forgotten Rotating Wing Aircraft Meetings offered a *priceless forum for pooling knowledge and exchanging ideas*. . . (emphasis added)

These gatherings were convened to advance both the [A]utogiro and the helicopter. Since no helicopter industry existed, the [A]utogiro community – represented by Harold Pitcairn, [W.] Wallace Kellett, [E.] Burke Wilford, Dick Prewitt, [W.] Laurence LePage, and Agnew Larsen, among others – initially dominated the proceedings. At the first meeting, LePage (who in November 1938 formed a helicopter company with mechanical engineer Haviland Platt) showed movies of Germany’s Focke-Achgelis Fa 61 helicopter, inspiration for

the Platt-LePage XR-1 helicopter of 1941. . . Proponents of the sharply divided [A]utogiro and helicopter camps set forth their views during these forums. There was universal agreement that the helicopter was enormously more complex than the [A]utogiro, but heated differences emerged over whether the former was worth the cost and bother when the latter could already do everything short of hover and fly vertically.”⁷

But if for Spenser the 1938 meeting was a battlefield upon which the proponents of the Autogiro and helicopter faced off, as will be seen, he misconstrues the timing – *it is after the Autogiro has lost the battle*; while Pitcairn admirer Frank Kingston Smith, in what can justly be described as a ‘devotional biography’ (privately printed by the Pitcairn family), portrayed the occasion in a more sinister and conspiratorial⁸ manner. He wrote:

“[Jim] Ray arrived at the Port of New York [sic] of October 26, 1938, accompanying, by sheer coincidence, an English helicopter inventor named Raoul Hafner ^[9], who was on his way to Philadelphia to attend the meeting on rotary-wing aircraft sponsored by the Philadelphia chapter of the Institute of Aeronautical Sciences at the Franklin Institute. The convocation, arranged by Ralph H. McClarren, himself an eminent rotary-wing engineer, and E. Burke Wilford, of Gyroplane fame, was slated to be a major gathering of experts in the narrowly defined discipline. Professor [Heinrich K. J.] Focke and Louis Bréguet had been invited, but had declined for personal reasons, sending papers to be read at the meeting by their friend Hafner. All of America’s leaders in the new science appeared, except Harold Pitcairn, who was confined to bed by illness, and heard presentations by such outstanding practitioners of rotary wing as Richard H. Prewitt, Gerard P. Herrick, (sic) Haviland Platt, W. [sic] Lawrence Le-Page, and [E. Burke] Wilford. Speeches were made by Congressman Dorsey and Lieutenant [H.] Franklin Gregory; Jim Ray reported on his recent experiences in Europe in an impromptu, completely extemporaneous speech, and introductions were acknow-

ledged by Grover Loening, W. Wallace Kellett, and several army officers in the Wright Field program. Pitcairn was well represented by Agnew Larsen and Paul Stanley. Another extremely interested spectator was Michael Gluhareff, an engineer long associated with Igor I. Sikorsky. During luncheon, Gluhareff, seated next to Gregory, informed him that Sikorsky had recently turned his full attention to the technical problems of hovering flight and control systems involved with it and invited Gregory to visit United Aircraft's Vought-Sikorsky laboratory in Stafford, Connecticut.^[10] Having already visited the Pitcairn and Kellett organizations while he was in Philadelphia, Gregory said he would detour to Stafford on his way back to Wright Field. It was an invitation that he could not refuse."¹¹

Smith would have his readers believe that H. Franklin Gregory was even then entering into a conspiracy with the Sikorsky company to channel Dorsey-Logan funds for rotary wing aircraft development and deny the Autogiro developmental funds! Dr. Sergei Sikorsy has effectively debunked this conspiratorial assertion¹² and Gregory's own recollection of the visit to Stratford claimed, with a decidedly non-conspiratorial emphasis, that:

"As early as 1938, Major Carl F. Greene (now a full colonel and Matériel Command Liaison Officer at the National Advisory Committee for Aeronautics (NACA)^[13] Laboratories, Langley Field) and I visited the Vought-Sikorsky Division in Stratford, Connecticut, to investigate the experiments the Sikorsky people were conducting on a new mechanism for vertical flight. *Correspondence about the device had been sent to the Matériel Division, and the Army deemed it worth-while looking into it.* This was, too, a time when we were looking for a new-type rotary-wing craft. Igor Sikorsky was not then at the plant but in Europe. His associates, Michael Gluhareff and Boris P. Labensky, showed us the unusual device, which was not a flying machine, but a test rig for trying out various rotor combinations."¹⁴ (emphasis added)

So, if viewing the 1938 meetings through a critical lens from a vantage point almost 70 years later fails to substantiate the posited confrontational or conspiratorial frame, what exactly *did* happen in late October at the Franklin Institute? The answer to that long overdue question will restore this historic gathering to its rightful position in the history of rotary wing flight, and provide insight on what will come to be justifiably seen as the moment when the Autogiro failed and the helicopter began an ascent that continues to this day.

The 1938 Meeting: An Historical Gathering

The *Proceedings of the Rotating Wing Aircraft Meeting* (142 pages of printed text + 13 pages of diagrams) begins with an anonymous acknowledgement¹⁵ on the first page of thanks on behalf of the Philadelphia Chapter of the Institute of Aeronautical Sciences, defining the scope of the meetings as "Uses, Developments and Relation to the Future of Heavier-than-Aircraft." It also pointed out that the *Meeting* delegates were invited to attend the regular meeting of the Franklin Institute on the Thursday evening prior to the conference at which there would be a lecture in the Hall of Aviation entitled "Principles of Rotary Aircraft" by Dr. Alexander Klemin, Professor, Daniel Guggenheim¹⁶ School of Aeronautics, New York University, an auspicious start as he was then arguably the most renowned exponent of rotary-wing theory in the United States.¹⁷

The Introduction then proclaimed that "[i]t was rather fitting that registration take place in this large hall devoted to a splendid collection of aviation exhibits and particularly in view of the fact, hanging from the ceiling is the first autogiro built in this country." While the setting in the Hall of Aviation was undoubtedly inspiring for the aviation-minded, the claim that the aircraft hanging above the registrants was the "first autogiro built in this country" is clearly incorrect. It was, in fact, the oldest *surviving American-built Autogiro*, the Pitcairn PCA-1A.¹⁸ Pitcairn's first experimental American-built Autogiro, the PCA-1, had been badly damaged in an accident while being flown by Juan de la Cierva in early October, 1929 and was destroyed in a fire that consumed the older Pitcairn hangar in Bryn Athyn, PA on November 18, 1929.¹⁹

The oldest Autogiro in America was (and is) the Cierva C.8W,²⁰ and although there is some controversy²¹ as to the date and pilot on the first flight in the 'New World', it now established that the

Cierva aircraft was first flown in America by Cierva test-pilot Arthur "Dizzy" Rawson on December 18, 1928.²² When the evaluation of the C.8W was complete, Pitcairn presented it to the National Air and Space Museum of the Smithsonian Institution on July 17, 1931 and it was accepted by Dr. Charles Greely Abbot, Secretary of the Smithsonian Institution when James G. "Jim" Ray landed on the National Mall on July 22, 1931.²³ The C.8W was on display for several years, but was transferred to the Smithsonian storage facility at Silver Hill, MD when it began to deteriorate. In 1982 Walter J. Boyne, who became Director of the National Air and Space Museum in February 1983, wrote that America's first rotary-wing aircraft "was scheduled for restoration in the near future."²⁴ That was 21 years ago and the C.8W still has not been restored and placed in an honored position in the Smithsonian. That aircraft awaits restoration at the Paul S. Garber Center of the National Air and Space Museum.²⁵

The Introduction then notes that "Mr. E. Burke Wilford, President of the Philadelphia Chapter acknowledges his gratefulness to the committee consisting of Agnew E. Larsen, W. Laurence LePage, Richard H. Prewitt, James G. Ray and Ralph H. McClarren, Secretary." This is telling in that Wilford, along with McClarren, was then active in the development of the Wilford Gyroplane; Ray and Larsen represented the Autogiro Company of America and the Pitcairn interests; Richard H. Prewitt was chief engineer of the Kellett Autogiro Company while LePage, a 'consulting engineer', was beginning development of one of America's first helicopters. It was a solid representation of the American rotary-wing community, with the exception of Igor Sikorsky and Harold Pitcairn (who was ill), appearing heavily but not exclusively tilted toward the Autogiro, but appearances were to prove deceiving.

Wilford, who had previously done significant work for the Pennsylvania Aircraft Syndicate directed towards aircraft safety, purchased the patent rights to the work of German inventor and aircraft designers Walter Rieseler and Walter Kreiser in 1925, thus predating Pitcairn's involvement with Cierva. The rights to Rieseler and Kreiser's rigid-blade gyroplane would be assigned to Wilford in U. S. Patent 1,777,678.²⁶ He called his craft the WRK Gyroplane (X794W)²⁷ and it first flew on August 5, 1931. It differed from the Cierva and Pitcairn models of the time in that utilized a rigid rotor capable of cyclic pitch variation. The pitch of the rotor

blades changed as they rotated, a mechanism to equalize lift in place of the Cierva flexible blades and "flapping hinges". This use of cyclic pitch also afforded a measure of control, but the Wilford model also retained wing and tail control surfaces.²⁸ While the Navy would eventually evaluate his second XOZ-1 Gyroplane in 1935 – 36, and it would be tested by the N.A.C.A., Wilford was never a serious contender to either Pitcairn or Kellett in Autogiro development. This was, in part, because his test pilot Joseph McCormick, brother of William McCormick who had been with RADM Richard Evelyn Byrd to the South Pole as his Autogiro pilot, died in a 1934 crash of a Wilford prototype.²⁹

Of greater interest, in terms of the later characterization of Frank Kingston Smith, is the inclusion of James G. Ray in the organizing committee. Smith's description that "Jim Ray reported on his recent experiences in Europe in an impromptu, completely extemporaneous speech" would seem to be at odds with both the significant role assumed (and acknowledged) of the organizing committee and actual presentation made by Ray, a paper entitled "Commercial Uses of Rotary Wing Aircraft",³⁰ a presentation that appears neither 'impromptu nor spontaneous'. So the question naturally arises – to what end would Smith deliberately mischaracterize Jim Ray's participation in the 1938 meetings? The answer is not long in coming – Smith continues two pages later:

"Within a few weeks of the Franklin Institute symposium on rotary-wing flight, Harold Pitcairn was back on his feet and able to hold a somewhat belated welcome-home party for Jim Ray in the secluded Stone Room, the scene of so many technical sessions. There, he and his associates could relax in a convivial, social atmosphere.

While bringing Ray up to date with recent developments involving the Autogiro Company [of America], the status of the PA-36 program was laid out in detail, including the optimistic outlook they all held for the military and commercial futures of the jump-takeoff cabin ship and its successors. Somewhat to everyone's surprise, having heard them out, Ray took an antithetical and unpopular position. He said quietly that, in his opinion, they were all following a cold trail and making a serious mistake by putting so much reliance

on the PA-36, and indeed the Autogiro itself. His own analysis was that the strong public reaction to the success of the Focke-Achgelis and Flettner machines presaged a demand for an aircraft with *hovering* capability, whether it was really needed or not, and that there lay the direction of rotary wing's future. As Pitcairn, Larsen, and Stanley sat astounded, Ray continued that while he had followed developments of many aircraft companies licensed by Cierva Autogiro, everywhere, Autogiro people were buzzing about the long shadow that the successful Fa-61 [helicopter, also known as the Fw-61] would cast on the future of rotary-wing flight and they had unanimously concluded that their future efforts should be concentrated on the development of aircraft that could hover. His strong impression was that any rotary-wing aircraft without that specific ability was a dead issue for military use – which was the only source of profitable orders under the circumstances of the worldwide Depression. Then he recommended that the PA-36 program be scrapped and be completely replaced by a helicopter development program.

His strongly stated position and suggestion precipitated a heated discussion which turned into an argument of increasing passion, with Ray on one side, Larsen vigorously defending the other, and Pitcairn sitting off to the side, listening intently. On many of the points made, he could agree with Ray, but on the whole he had to go along with Larsen: the Autogiro would do everything that the helicopter could do, except hover. He was aware that Cierva-Focke-Achgelis cross-licensing agreement had been made within the complex framework of the Cierva-created European Autogiro industry, but had spent so much time and money on Autogiro research and development which had resulted in successful commercial applications of the ships, that he still had confidence in their outlook. In addition, he had made the decision to trust the future of his company the advanced technology of the PA-36^[31] in a maximum effort that was already well under way and did not believe that it was technologically, financially, or

politically feasible to switch courses in midstream

Pitcairn also faced another acute problem which could be solved only by him. For many months he had been told by his accountants that the two-thousand-dollar-a-week drain on his resources would lead to serious consequences if he did not do something to stem the flow. He was paying top salaries to Larsen, Stanley, several draftsmen and machinists, and to Jim Ray. While Ray was in Europe, the company could somewhat justify his retention on the payroll, but now that he was back, the total lack of any flying activities simply did not justify paying his high salary to have him sit around doing nothing. A dreadfully painful decision had to be made – a particularly distressing one in the light of the disagreement between his two close friends with whom he had begun his aviation enterprises so long ago on the cow pasture in Bryn Athyn. When all the scales were balanced, they weighed heavily in favor of retaining Larsen, who was fully committed to administering the production program of the PA-36 prototype, already well under way, although he had missed the deadline for demonstrating it at the congressional hearings. Pitcairn had already forgone any salary from the company, so that only one last personnel cut was possible. It fell on Harold Pitcairn's reluctant shoulders to tell Jim that he was going to have to find other employment.³²

As Smith would have his readers believe, the firing of Jim Ray was the logical result of a logical, economic rationale; yet what emerges is the antagonism and tension between Pitcairn's unwavering commitment to development of the Autogiro and Ray's view of helicopter advancement and rising enthusiasm. There surely was a psychological dimension to his termination, here ignored by Smith in his devotional biography of Harold F. Pitcairn, a advocacy further reinforced by diminishing Ray's role in the 1938 meetings and characterizing his participation as an "impromptu, completely extemporaneous speech." In fact, as will be seen, Ray's presentation was extremely positive in terms of describing commercial uses for the Autogiro, with only a marginal comment regarding the use of

the helicopter by the U.S. Coast Guard in rescues at sea.

The First Session – Friday, October 28, 1938 - Introduction

The Introduction was given by E. Burke Wilford in his role as Chairman of the Philadelphia Branch of [the] institute of Aeronautical Sciences. He noted that

“As this is probably the first rotary wing aircraft conference occurring in the world, we hope to make a little history here, and the only way that we can do that is for everyone to say what he thinks. Don't be afraid of hurting anybody's feelings, or departing from conventional procedure. That what this meeting is for, and we hope that it will be the start of a real boom in the rotary wing aircraft industry. We hope to see that within the next ten years, there will be at least 10,000 men working in this industry. To all you young men that are here, why, this is the line to work in, because it is going places.”³³

This must be regarded as an extremely optimistic view given that the national economy had not pulled itself from the Depression, the American Autogiro movement was, and had been for several years, moribund, and the attention of the aviation world had been drawn to the successful German achievement of rotary-wing in the Focke-Achgelis Fa-61 helicopter. The Germans has been most anxious to show off the Fa-61³⁴ and had willingly and publicly demonstrated the Fa-61 from a distance – but in the fall of 1937 the Fa-61 had been flown before the world's most famous living aviator, American Colonel Charles A. Lindbergh, then a personal guest of Hermann Göring who wanted to proclaim the advances in German air power. Lindbergh's reports to the American military community of the vertical flight achievements of the Fa-61 were insightful, perceived of as accurate, authoritative, and alarming.³⁵ The public took sharp notice when the world's first female helicopter pilot, Hanna Reitsch (dubbed the German “Amelia Earhart” and who had recently been given the honorary rank of Flugkapitän (“Flight Captain”) in recognition of her many research flights in gliders and warplanes), flew the Fa-61 inside the Berlin Deutschland-Halle,³⁶ a large meeting hall, before

thousand of spectators in February 1938. It has been claimed that the spectators consumed so much oxygen that it reduced the Fa-61's engine power, necessitating airing of the arena during the demonstrating flights.³⁷ Chosen, in part for her photogenic and propaganda appeal, and perhaps in equal part for her petite stature and slight weight, given the limited lifting ability of the small helicopter, it was an inspired performance. Pictures of her controlled, indoor flight stunned the world in general, and aviation designers and military leaders in particular – including American Army aviator 1st Lieutenant H. Franklin Gregory, who would shortly be tasked with the oversight of American rotary-wing aircraft development.

Additionally, the contemporary American press had not, in fact, been kind to the Autogiro industry for some time. David Ingalls' “Missing Link” article in the March 1931 issue of *Fortune*³⁸ which had highlighted the advent of the American Autogiro and, as the constant flow of Pitcairn Autogiro advertisements, called attention to the power and potential of the Autogiro, touting its safety and easy of flight training, promising a virtual revolution in American aviation. And indeed, an article in the December 1930 *Aero Digest* trumpeted the safety of the Pitcairn Autogiro for the neophyte, claiming that “a novice . . . is placed in much the same position as when learning to drive a motor car. Mistakes are not necessarily dangerous. If he becomes confused, he can stop and let the ship land itself.”³⁹

But the March 1932 *Fortune* article “Autogiros of 1931 - 1932” took a far darker tone than a year earlier.

“Obviously autogiros are not flying every corner of the sky. Obviously, too, consciousness of the autogiro has come up over America's horizon. The autogiro has hopped on the lawns of the White House, the Capitol, and the Smithsonian Institution, where the first autogiro to fly in this country delivered itself to the very portals within which it is now immortalized. It has alighted on golf courses, on the piers of ocean liners, and once, when it ran out of gas, it settled at night into the back yard of a farmer. And some sixty-one commercial (as opposed to experimental) autogiros have been sold today as compared to one a year ago.”⁴⁰

And the right hand black-bordered column of that article was entitled “Worst Autogiro Accident” and listed ten different accidents including Amelia Earhart’s Abilene crash,^[41] a brief account of Blanche Noyes’ withdrawal from flying the Standard Oil Company of Ohio’s PCA-2 after two hard landings that cracked the undercarriage, and accidents by private and military pilots, and even the “Miss Champion” professional pilot Captain Lew Yancy. And although the end of that accident report stated that “[i]n all cases the occupants of the machines were able to walk away from the accidents” it could not have been of much comfort to Pitcairn and his associates. And the center of the last page of the article featured, in a heavy black-bordered box, a riveting photo captioned “Behold the first commercial autogiro to be totally destroyed – but not in a flying accident. This big Pitcairn machine, belonging to United Aircraft, was idling on the ground . . . when a backfire started a blaze” The news photograph showed the PCA-3, which was the first (NC11671) of two PCA-2s fitted with 300 hp Pratt & Whitney R 985 Wasp Junior engines in a special order for United Airports, a subsidiary of the United Aircraft and Transport Corporation. As it was merely a version of the PCA-2, it was speedily granted an ATC on August 25, 1931, but was destroyed in a fire less than a month later. The photo, showing a fuselage on fire and smoke billowing from the cockpit, viscerally reinforced the theme of the article – while Autogiros accidents were not fatal, they were costly and the aircraft had not lived up to its promise of safe aviation. . The article pointed out that the Pitcairn PCA-2 then sold for the hefty price of \$15,000, “whereas an airplane of similar size and power might cost \$11,000 . . . and the Pitcairn sport model for \$6,750 – and here is the real difficulty. An airplane to yield the same service might cost only \$1,500.”⁴²

In March of 1936 *Fortune* revisited the Autogiro with an article⁴³ entitled “Autogiro in 1936” and expressed a decidedly different view than the previous Ingalls’ 1931 article. In evaluating the Autogiro, the magazine viewed the coming of direct control as portending a “rebirth” – and, in evaluating the previous models that it had waxed so eloquently about five years earlier, stated plainly that the Autogiro had “turned out to be a lemon . . . for all practical purposes.” While the unidentified writer recognized that the Autogiro was “still the only flying machine that could rise from a narrow lawn, loaf through the air as slowly as twenty-five miles an hour, and, if its engine died, settle to earth as

gently as a parachute,” went on to assert that “the trouble was . . . it would do those things generally only in the hands of experts; and it would *not* do, even for the experts, certain other desirable things, like flying fast and carrying a decent load. (“Half the speed for twice the horsepower” was the contemptuous jibe of airplane pilots and engineers.)” Harold F. Pitcairn, previously described as an “Impresario” in 1931, now was characterized as “a rich, scholarly Pennsylvania socialite of somewhat ascetic tendencies and mathematical bent” who with “his brothers Raymond, a lawyer, and Theodore, philosopher, artist, and Swedenborgian minister . . . shares the wealth of the Pitcairn Co., which has notable holdings of Pittsburgh Plate Glass.” Being portrayed, not as an aviation visionary but as a rich dabbler, was no doubt a painful denunciation, and Pitcairn could not have helped but be further dismayed at the magazine’s assertion that Cierva “had regarded the whole Pitcairn venture in the U.S. as a large testing ground on which the giro would be given a thoroughgoing workout under all sorts of conditions, while he perfected the design for market in Europe.”⁴⁴ However, in the same article containing those words was a powerful visual testimony of the coming of age of the Autogiro, for in eleven sequential photos that started horizontally from the lower left corner of page 88, continued vertically up the left side of the facing page and then horizontally across that page showing the first pictorial record of an Autogiro making a jump take-off, a C.30 (G-ACFI) piloted by Juan de la Cierva.

And in an illustration spanning the center section of two following pages, the magazine introduced the reader to the latest Pitcairn development, the “roadable” Autogiro capable of achieving speeds of 110 mph in the air and then, upon landing and folding its blades backward, driving along the highway at 25 mph. In final evaluation of the achievement of direct-control, the jump take-off and the American roadable Autogiro, *Fortune* concluded somewhat unenthusiastically with a lukewarm declaration (in light of the article’s previous commentary) that “after sixteen years the autogiro has only now become an autogiro.”

Yet this optimism may not have been totally unfounded, for while the advent of the direct control/jump takeoff Autogiro did not exactly excite the uninformed public, the ‘roadable’ Autogiro did receive media attention as seen in the October 1935 issues of *Bill Barnes Air Trails* and the July issue of *Modern Mechanix & Inventions Magazine*.



And, – as noted above, James G. Ray and John M. Miller,⁴⁵ as authoritative Autogiro pilots as were



then in America, were optimistic about the commercial uses for the Autogiro as was Professor Otto Lunde.⁴⁶ The popular media was even then, and had been for a few years, experiencing a renaissance of Autogiro imagery that subtly (and not so subtly) posited an optimistic Autogiro future. This had been seen in the October 1929 *Scientific American* with an artistic rendition of the Cierva C.8W making a night landing at Newark Airport⁴⁷ while the *National Farm Journal* portrayed the agricultural uses of the Autogiro in July, 1931; the January 1933 issue of *The Open Road for Boys* depicted an intrepid adventurer being rescued from native savages by an Autogiro,⁴⁸ a *Popular Sci-*

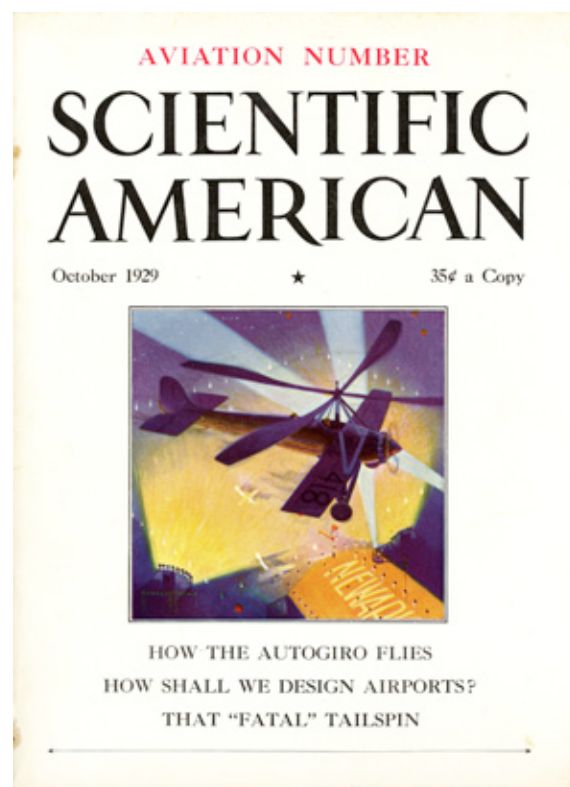

ence image of a bi-rotor Autogiro in 1934,⁴⁹ as well as images from the 1935 *Model Airplane* and 1936 *Bill Barnes Air Trails* magazines of proposed military applications of the Autogiro as well as the May 1931 *Meccano Magazine* and the 1934 June *Practical Mechanics* in England. John M. “Johnny” Miller, who celebrated his 100th birthday on December 15, 2005, a participant in the 1938 meetings, had just published an article entitled “The Missing Link In Aviation” in the previous month’s *Popular Mechanics Magazine*⁵⁰ which showed a

direct-control Autogiro landing on a metropolitan building roof.





Additionally, viewers in America and England had been exposed to images of the Autogiro in the 1932 films *Misleading Lady*, *Adventures in a Windmill*,⁵¹ the 1933 films *His Lordship* (English),⁵² the W. C. Fields film *International House*, the Saturday morning serial-

adventure *The Whispering Shadow*, the 1934 Academy Award-winning film *It Happened One Night*,⁵³ the 1935 films *The 39 Steps* (England) and *Ladies Crave Excitement* (showing John M. “Johnny” Miller doing two loops in a Pitcairn PCA-2 Autogiro.⁵⁴

The Autogiro had also been featured in children’s literature beginning in 1930 with Eustace L. Adam’s ‘Tom Strong’ teenage aviator adventure book *The Flying Windmill* in 1930,⁵⁵ John Anderson’s *Wonders of the Air*,⁵⁶ J. T. Gorman’s *Gorilla Gold*,⁵⁷ *Air Babies*⁵⁸ by Elvy Kalep (forward by Amelia Earhart) with its character ‘Jenny Autogyro’, Edith Lavell’s 1931 adventure series for young girls *Linda Carlton’s Island Adventure*,⁵⁹ Marjorie Hardy’s 1933 *Sally and Billy in Winter*,⁶⁰ Cyril Cowell’s 1935 *Transportation Picture Reader*,⁶¹ and the 1936 mystery *The Dark Green Circle*.⁶² And this literary use of and embellishment of the Autogiro would continue after the 1938 meetings.⁶³

Wilford then concluded his introduction by introducing Ralph H. McClarren of the Franklin Institute,⁶⁴ whose *assigned* task was to provide a brief “Review of Rotating Wing Aircraft.”⁶⁵ His summary then may have been engaging and innovative, but now certainly be regarded as a standard, if somewhat fanciful, introduction to autorotational flight. He began with accolade to the Klemin paper from the night before, and then marched through a litany of autorotational historical antecedents beginning with the venerable maple seed (which he dropped in demonstration),⁶⁶ the Australian boomerang, the children’s toy⁶⁷ ‘Chinese top’, and displayed a model of a Pitcairn Autogiro (courtesy of Pitcairn engineer Paul Stanley) which displayed autorotation as McClarren waived it about, even as he proceeded to reference Leonardo Vinci’s design for an ornithopter. McClarren showed slow-motion movies of a hummingbird in flight, impressed by its ability to hover (hence its position on the AHS emblem), and then proceeded to show demonstrations from the ‘Franklin Institute traveling air show’ including a fixed wing flier employing a large aspect wing.

He then intrigued the audience (and indicated the direction of the research at the Franklin Institute) by showing an incomplete model (“I had hoped to have completed to actually demonstrate vertical flight”)

“[N]ot like the autogiro or the gyroplane, all types of which you will hear of later on, but this helicopter type: The model contains

all the essential principles of a single rotor helicopter, -- the rotor to be power driven. There is a torque reaction to counteract, so we would rev this prop up a little bit or change the pitch of it, to counteract the torque. When we want to go forward, we change the pitch, and have both props turning, use them to help our forward propulsion, tilt the rotor, and also use the forward component or sine angle, Theta, to help in the forward propulsion.

There is another little trick we might do that the model doesn't show. To effectively use these two little propellers for forward propulsion, we could put a small wing on one side of the fuselage, another wing or slot wing effect on the other side, aft, and then in forward flight, the would be enough (sic) enough speed and enough lifting force on those, to counteract the torque caused by the power put into the rotor"⁶⁸

It is interesting to note that such a design with counter-rotating propellers, which McClarren was proposing, already existed – the TsAGI EA-11 designed by Russia's Ivan Pavel Bratukhin.

By the mid-to-late 1930s Russia, aviation designer Professor Ivan Pavel Bratukhin of the TsAGI aeronautic research facility already had several years of rotorcraft design. When TsAGI set up a helicopter research section under Boris Yuriev, Bratukhin briefly joined it in 1926, but soon left for additional studies at the Bauman Technical School in Moscow, where he graduated in 1930. Returning to TsAGI, he was placed in charge of a brigade that developed the 11-EA⁶⁹ between 1936 and 1938. This model sought to combine the capacities of helicopter, Autogiro and fixed-wing aircraft but it failed to accomplish its task and its development fell victim to politics.

The Bratukhin-designed 11-EA (for *Experimentalnyi Autozhir* or *experimental autogiro*)⁷⁰ was, having been under conceptual development since 1933, constructed in 1936. With the appearance of a conventional two-passenger aircraft with an Autogiro pylon topped with a six-bladed rotor consisting of three shorter rigid blades capable of feathering (changing pitch) and three longer, articulated blades. As this craft was to take off as a helicopter, Bratukhin placed counter-torque propellers (rotating in opposite directions from each other) on the forward edge of each wing

which would push and pull in opposite directions in helicopter (hovering) mode. In forward flight, however, both propellers pulled forward even as the rotor was unloaded as an autogyro. The 11-EA had a streamlined fuselage and was powered by a 630 hp Curtiss⁷¹ Conqueror engine mounted in the forward part of the fuselage with a large fan-equipped radiator in front. Tethered flight testing began in 1936 and continued until the next year. These tests, only in limited helicopter mode, revealed control problems due to the complex 6-bladed rotor. However, external circumstances including Stalinist purges, forced relocations of key personnel and fear of being accused of sabotage if tests encountered difficulties slowed testing and subsequent development by 1937 doomed this compound aircraft.⁷²

The development of the 11-EA, characterized by a reluctance to advance to full untethered flight testing in 1937, was dictated by the official retribution for failure increasingly exacted by Soviet dictator Joseph Stalin who saw treachery in such lack of success. Bratukhin and his associates were constantly confronted with reports of arrests of fellow engineers who had failed to deliver the desired results. As precisely observed by Lennart Anderson in *Soviet Aircraft and Aviation 1917 – 1941*, "No one wanted to risk making a mistake and be accused of sabotage."⁷³ Indeed, Bratukhin's test pilot, Aleksei Cheremukhin was arrested and imprisoned with other Bureau colleagues.⁷⁴ By late 1938, even as McClarren was proposing his design the participants in the Franklin Institute meetings, the Soviet political climate was such that it was judged improvident and unacceptably risky to continue the development of this compound aircraft. The 11-EA was rebuilt between late 1938 and December 1939 as the 11-EA-PV, a pure helicopter version with the wings replaced by framework booms with two auxiliary rotors on each side for torque control. Beginning flight testing in October 1940, no one mourned it when it last flew in 1941.

After apologizing for not having a complete model to demonstrate, McClarren turned to 'dry-ice in lukewarm water' model of a wind tunnel and applied it to a model rotor. Turning on a fan, he achieved autorotation to demonstrate velocity vectors through the disc as shown by the dry ice fumes. He speculated that: "But as we increase the angle [of the rotor section from a low angle of attack] , we change from that down force characteristic to another one at the high angles, where we

merely block the flow of air rather than having a down-flow characteristic. (Indicating) And that transition point is the one in which the aeronautical engineer has to make his best guess when developing the theory of rotor operation.”

And leaving his listeners with that speculation, he completed the introduction and “start[ed] the regular session promptly.”

The First Session – Friday, October 28, 1938 – 10:30 AM – 12:30 PM

Dr. Alexander Klemin served as Chairman for the first session and he promptly introduced the first presenter, who “made for himself an international reputation as an autogiro engineer, which is equaled by few and surpassed by none”⁷⁵ Richard H. Prewitt, who was then chief engineer of the Kellett Autogiro Corporation. His presentation was fitting titled “The Autogiro”.⁷⁶

Prewitt then proceeded, prior to the commencement of his content, to “introduce those who have been responsible for this meeting.” He named: E. Burke Wilford, Mr. Ralph McClarren, Laurence LePage, Agnew E. Larsen, and James G. Ray. These last two are of particular significance – employees of the Autogiro Company of America. And although only for former would be named a representative of the company by Frank Kingston Smith, as noted *supra*, it is obvious that *both* had played an organizing role in the Franklin Institute meetings. Prewitt then went to acknowledge a non-organizing committee participant, W. Wallace Kellett, with this accolade “[t]here is another man prominent individual in recent years in promoting and obtaining that necessary financial and general support for the further development of the autogiro. *It was largely through this man’s energetic and persistent efforts that the Dorsey-Logan bills passed the House and Senate respectively*; thereby creating the recent surge of Rotary Wing Aircraft enthusiasm which emanated there from. Believing this man, though not an engineer, [Kellett] has indirectly played a prominent part in the Rotary Wing Aircraft enthusiasm demonstrated here, I take pleasure in introducing Mr. W. Wallace Kellett.” (emphasis added)

It is interesting to note that Frank Kingston Smith totally fails to note Kellett’s role in advocating governmental support vis-à-vis the Dorsey-Logan Bill,⁷⁷ while Prewitt does not even allude to Pitcairn’s contribution towards the successful Dorsey-Logan funding advocacy.⁷⁸ But, as discussed

later, given the then-extant rivalry between the two Autogiro leaders, and perceived competition for funding, such omissions were to be expected. But as we shall see, in this case it may be that Smith and Prewitt perhaps unjustly ignores Pitcairn, who surely played a major role with local congressman in lobbying for support of rotary-wing aircraft (although Pitcairn *and* Kellett probably each advocated for *Autogiro* support – as we shall see, the Dorsey Bill didn’t work out as intended for either party).

Prewitt then went on to briefly pay tribute to Juan de la Cierva, who had perished in the crash of a KLM DC-2 at Croyden Airfield in England on December 9, 1936 (Pitcairn was shortly to publish a personal tribute to Juan de la Cierva – see Pitcairn, Harold F. *Juan de la Cierva*. Autogiro Company of America January 9, 1939). The half-page tribute was clearly based on *Wings of Tomorrow* which had been published by de la Cierva and Don Rose in 1931⁷⁹ but several other original participants in Cierva’s endeavors also had published books giving the basic history of the early days of Cierva’s endeavors, notably test-pilots R. A. C. “Reggie” Brie⁸⁰ and Arthur “Dizzy” Rawson.⁸¹

Prewitt followed with a superficial summary of the American⁸² and English Autogiro organizations/achievements, merely citing but not elaborating on the “latest developments of the Autogiro; namely jump-off and road-ability” and merely referring the audience to his soon-to-be-published paper on the jump-[take]off Autogiro⁸³ while noting that “the jump-off feature has great promise for increasing autogiro utility by further reducing the necessary field size required for operations.”

Prewitt ended his formal presentation with a description of the development at Kellett Autogiro Company of the KD & YG models, the civilian and military versions of the direct-control Autogiro,⁸⁴ complete with a short film of the aircraft. This was perhaps a challenging moment for the Pitcairn representatives in the audience as the Kellett KD-1 was the first direct-control Autogiro to go into production in America.

At the conclusion of the Prewitt presentation, the session chairperson Dr. Alexander Klemin, sensing that it had been extremely one-sided in its almost exclusive emphasis on the achievements of the Kellett organization, immediately called upon Paul Stanley to discuss Prewitt’s paper, but to little avail as the Pitcairn Autogiro Company engineer declined to comment beyond thanking the pre-

sender especially for the film presentation, noting that it had “shots from quiet number of sources.” Dr. Klemin echoed Stanley’s gratitude and further noted that the film presentation had included shots of the “Hafner gyroplane”, an effective segue to introduce Raoul Hafner who was in the audience, but he declined further comment, noting that he had been allotted time to make a presentation later in the program.

Dr. Klemin then turned to the second paper presentation, entitled “The Convertaplane” to be given by Garard P. Herrick,⁸⁵ then president of the Vertoplane Development Corporation of New York. Herrick, a cousin of Myron T. Herrick, the U.S. Ambassador who greeted Charles Lindbergh upon his arrival at Paris, began with an explanation of the origin and correct spelling of the name of his aircraft: “I might settle this question of spelling of name of my aircraft first. (Goes to blackboard and writes, (sic) “CONVERTibe Air PLANE” (probably incorrectly recorded but should have been Convertible Air Plane). (Notwithstanding this declaration, Herrick contradicted himself in 1949, changing the spelling to Convertoplane when he presented a paper⁸⁶ at the 1st Convertible Aircraft Congress (Sponsored by the Philadelphia Sections of the American Helicopter Society and the Institute of Aeronautical Sciences in Philadelphia, PA on December 9, 1949)).

Herrick noted that:

“[T]he invitation to speak here today is particularly appreciated, because I represent a hybrid, an occupant of the aviation stables that more closely resembles, perhaps, the mule than anything else. We are all interested to find out whether or not it is the start of a new and important breed. I might say that my attitude is somewhat that of the man who say a burglar in his room, and he said, “Here, what are you doing there?” “Why”, he said, “I am looking for money”. “Well”, he said, “wait a minute and I’ll get up and help you look.”⁸⁷

Before he proceeded to describe the development of an aircraft that could fly as a bi-plane, but then convert midair into an autogyro (note, not an Autogyro as this technology and model was not founded on a Cierva or Cierva-derived license [e.g., from the Autogyro Company of America]), Herrick read a poem by Al F. Lewis entitled “One

of Our Simple Problems” which supposedly embodied “statistics” in an allegedly humorous fashion – as we shall, this was not received as apparently intended, but which reception did not then deter Herrick (or even later as he reused the poem 11 years later!).⁸⁸

Pitcairn’s fellow Philadelphian Gerald P. Herrick then detailed the HV-2A Convertaplane,⁸⁹ an initial attempt to combine fixed and rotary wing flight (he called his various iterations alternatively Vertoplane, Convertiplane, Convertoplane, and the eventual generic Convertaplane). Assisted by Ralph H. McClarren, Herrick and his associates sought to combine the best features of fixed-wing flight and the Autogyro. He had carefully considered Cierva’s developments and by early 1931 had decided that while the safety of autorotation was obvious, the problem was the relative lack (drag) of efficiency in horizontal flight. His ingenious solution, developed after much wind-tunnel experimentation, was a symmetrical airfoil, mounted on a central rotor pylon that allowed aerodynamic adjustment for control. This was, in essence, a biplane with a two-bladed single cantilever upper wing --- the Herrick Convertaplane took off as a conventional biplane and then converted into a gyroplane with the upper wing rotating to provide lift on a central pylon. Its upper wing did not hinge like typical Autogyro rotor blades, but sat on a hinged mount, using standard ball bearings, which teetered to compensate for the lift differential between the advancing and retreating sides.⁹⁰

And while Herrick touted his Convertaplane as the first attempt to combine these two aerial technologies, it is impossible to know if he was aware that he had been beaten into the air by the apparently successful flight of a similar aircraft by C. L. Stauffer of Elkhart, Indiana. In the fall of 1930, Herrick had employed F. E. Seiler, formerly chief-engineer at Kellett Aircraft Company to assist in the design of the then-called vertoplane. Ralph McClarren may have recommended Seiler as he had been his assistant at Kellett. This was apparently a closed-end consultancy, because after Seiler delivered drawings and reports regarding the Vertoplane, he commenced employment at the Heath Aircraft Company, which had been founded by Ed Heath in 1926.⁹¹ Seiler, before his death in mid-1931, apparently sold the Vertoplane concept (and perhaps the actual drawings and reports) to C. L. Stauffer, a promoter and Heath dealer. And while Herrick would contract with Heath to build his first model, C. L. Stauffer apparently also

proceeded to independently construct and successfully fly a now-forgotten 'convertible gyroplane' as shown in an obscure news clipping preserved by the "Ghost Airfields of Indiana Project."⁹²



Herrick's initial design, the HV-1,⁹³ dubbed the Vertoplane (X11384), flew for the first time on November 6, 1931. Powered by a tiny three-cylinder 48 horsepower Poyer engine (the contemporary 1931 Pitcairn PCA-2 and PCA-3 Autogiros were powered Wright R-975/E and E2 engines with 240 – 300 hp, while Pitcairn's attempt to create a lighter craft, the PAA and PA-18 autogiros featured Kinner engines with 125 – 160 hp), its crash in its maiden flight resulted in the death of its pilot. Taking off in biplane mode, the pilot released the upper wing in transition to autogyro mode to descend, but the aircraft vibrated uncontrollably and almost immediately dove to the ground.⁹⁴

Undeterred, Herrick immediately set about designing a new model. By 1936, after much redesign and experimentation, and securing financial backing, he had constructed the Herrick HV-2A (X13515). Then called the Convertiplane, this was a much more sturdy craft embodying significant design improvements – the upper wing/rotor was now reduced in size (to 24 feet) in comparison to the lower wing (28 feet); and an electric motor was employed to start the engine. Flight testing of the biplane, with full cantilever wings, but lacking struts or wires between the wings, began in October of 1936 at Boulevard Airport in Northeast Philadelphia with a pilot more distinguished by his drinking and carousing than dedication to the

project. Herrick soon replaced him with George Townson⁹⁵ who had been active with Pitcairn aviation, and who claims to have had words with Amelia Earhart just before her historical 18,415 feet altitude record in a PCA-2 in April 1 of 1931.⁹⁶ The gross weight of the aircraft was 1700 lbs., and the engine was the 125 hp, air-cooled, 5-cylinder Kinner. After the HV-2A flew satisfactorily as a fixed-wing craft, the flight testing turned to the autogyro (rotating wing) mode.

The HV-2A was not able to 'spin up' the upper wing (rotor) mechanically as no connection had been made to the engine, as on the Pitcairn PCA-2. In the air, the upper wing would be released to rotate, initially powered by several 5/8 inch, rubber bungee cords inside each upper wing half and running through an aluminum tube. Each of these wing cords was connected to a cable which wound around a spool. Prior to takeoff, two people would grasp each wingtip and walk twice around the central pylon in the opposite direction to autorotation – the upper wing was then locked in the biplane cantilever wing position. When the pilot released lock, the bungee cords would cause the wing to rotate for two turns at 60 revolutions per minute. The now-spinning wing would then rotate freely and the flow of air through the disk would increase its speed to 220 revolutions per minute in autorotation.⁹⁷

Understandably, the first tests of the HV-2V's autorotation abilities were not in conversion from horizontal flight, but in take-off as an autogyro. There, bungee cords could not provide sufficient rotation to achieve flight, so the HV-2V was taxied around the perimeter of the airport with the flow of air slowly increasing the rpm of the rotor (as with the early Cierva and Pitcairn autogiros). Takeoff was achieved with 180 rpm, and, once airborne, autorotation increased to 220 rpm. The rotorcraft flights proved the abilities of the HV-2V in autorotational flight, so the decision was made to attempt a mid-air conversion. However, in both autogyro and biplane modes, higher-than-expected drag was noted as well as a tendency to veer to one side. While the former was never solved, the latter was controlled by pilot technique.

For safety the first conversions from biplane to autogyro were at low level --- and were successful. A public demonstration on July 30, 1937 gained national publicity when the media photographed the air-to-air Convertiplane conversion at 1500 feet, and the inventor was heartened by expressions of interest by United

States Navy, but little came of that as no funds were provided for further development. With the public demonstrations in Germany of the helicopter and the coming of WWII, interest dimmed in Herrick's vision although he continued to design (but not construct) more sophisticated machines, earning him the title of "dean of convertible aircraft designers". The HV-2A made more than 100 air conversions prior to retirement to the Smithsonian Institution's Silver Hill Restoration Facility in 1954.⁹⁸

Herrick's presentation constituted a history of the development of his aircraft, and furnished the basis for his paper eleven years later at the 1st Convertible Aircraft Congress which was sponsored by the Philadelphia Sections of the American Helicopter Society and the Institute of Aeronautical Sciences in Philadelphia, PA on December 9, 1949. (In that later meeting, however, he dealt with a newer design, the HC-6D, which currently exists only as an exquisite wooden model in the NASM collection. While Herrick's work went unrealized and, in the scope of history, largely unrecognized, he advanced the serious question of combining the benefits of rotary-wing flight with the efficiency of a fixed wing aircraft, and set the stage for two later convertiplane attempts that, although ultimately unsuccessful, were arguably more of a technical success – the Fairey Rotodyne⁹⁹ (1957 – 1962) and the Kamov Ka-22 ("Vintokrulya" or "Russian Rotodyne")¹⁰⁰ (1960 – 1965?). Herrick also sketched uses/advantages for a convertiplane, stating: 1) speed differential; 2) steeper angle of descent than airplane; 3) minimum landing space; 4) inherent stability and automatic landing; 5) pancaking maneuver ("tired chicken landing") [describing a gyrocopter 'flared' landing]; 6) lateral and longitudinal control of aircraft via the rotor; 7) "fly with speed and landing with safety anywhere at any time"; 8) possible increased reliability of service because if the convertiplane encountered bad weather, it would be able to land and 'wait it out'; 9) smoother flying characteristics in rough weather; 10) public confidence justifiably established; 11) efficient take-off; 12) bombing (using the aircraft's ability to hover to aim bombs; 13) Naval reconnaissance; and 14) range or endurance.

In concluding his advocacy for the Convertiplane, Herrick stated that "[t]he Three Musketeers of the Convertiplane are present. As every engine needs an eccentric to bob up on special occasions for special purposes, we have an eccentric in the inventor; also the expert aero-

nautical engineer, Ralph McClarren, to keep the inventor within bounds and incorporate his ideas in the best practice, and the pilot, George Townson, who was courageous enough to prove the safety and simplicity of this new converting form of flight." Herrick was certainly correct in part of his assessment – he certainly was and continued to be an eccentric.¹⁰¹

Dr. Klemin was perhaps most kind when he reasserted his chairmanship of the session with the almost paternalistic declaration "I am sure, gentlemen, we all enjoyed Mr. Herrick's paper immensely, and never have I seen anyone so sincere, modest and what should we say, - gentlemanly, in the presentation of his own ideas. I think it is quite refreshing, and you will notice that Mr. Herrick's humor is particularly subtle, though very mild. The only thing I don't approve of are his mathematics. (Laughter) I think his mathematics are of the type of which the college professor, in marking down a paper say, "I think I shall give him a C, minus." And then, citing the need to move on to the next paper, Klemin did not allow any further discussion of Herrick's paper, a circumstance that in many ways paralleled Herrick's subsequent career. Klemin proceeded to introduce Haviland H. Platt who spoke on "The Development of the Helicopter Past, Present and Future."¹⁰²

If Klemin's final characterization of Gerard Herrick had effectively served to marginalize his ideas and endeavors, the introduction of Haviland H. Platt positively conveyed a *gravitas*. Klemin opined "Mr. Platt is a man who had added to great mechanical ability and ingenuity, a very critical understanding of aerodynamics, and I am sure that we shall be most interested in hearing the views on the helicopter of somebody who has actually worked in that air very definitely." LePlatt, a "mechanical engineer and patent expert with a number of rotary wing patents"¹⁰³ who had partnered with W. Laurence LePage in 1935 to pursue helicopter development. The partners had investigated the Fa-61 helicopter and LePage had actually negotiated with Focke to build helicopters in the United States, a venture that became impossible with the rise in tension between the two countries coinciding with the rise of National Socialist (Nazi) government in Germany. In November 1938, less than a month after the Franklin Institute meetings, the two aviation innovators/ entrepreneurs would form the Platt-LePage Aircraft Company. And even if the Platt-LePage helicopter failed to go into general production, eventually

eclipsed by the single-rotor design of Igor Sikorsky, the inventors were the first to suggest the helicopter gunship, a large twin-engine helicopter and the tiltrotor. Bell Aircraft would eventually pay royalties to Platt for use of his patents in the XV-3. But in October 1938, that was still in the future.

Platt saw his assigned 20-minuted presentation “to discuss the entire, enormous field of helicopter development” as being asked to “condense the Encyclopedia Britannica into one small volume” but he had decided to “dig around in the great amorphous mess that was presented, and try to find some little vestige of backbone or connecting thread in all of them and stick strictly to that.” His ‘backbone’ of helicopter development’ consisted of: 1. Past – Attainment of sustained free flight without regard to utility or safety. 2. Present – Provision or adequate flight control and safety, and 3. Future – Attainment of high useful performance.

It was through this rubric that Platt approached a chronicle of helicopter development, and he began with the “Berliner model of 1920,” showing a slide of it hovering while being guided by “intrepid gentlemen.” In achieving the solutions to the control issues presented by early helicopter development, control then-seen in the “remarkable stability of the Focke helicopter”, Platt thought that “it seems almost incredible that in the reduction to practice of this simple solution [the lift-screw is flexibly attached to the shaft so that when the shaft is tilted the disk or cone of rotating blades lags behind to some degree so that the thrust T stays in line with the disk axis and not with the shaft axis, achieving inherent stability] had to wait thirty years.” He goes on to observe:

“Especially is this so when it is found that descriptions of this device, in the form of the articulated rotor, have been in public print for almost this entire time. Thus Fig. 4 (Slide) is a reproduction of the drawings of a German patent (214228) issued to Degn in 1909 which show universally articulated blades. Incidentally, it is interesting that Degn also illustrates an overrunning clutch and describes correctly the theory of autorotational emergency landing. Fig. 5 (Slide) shows the drawings of a British patent (16,621/1913) to Pollacsek, which is identical with a German one (249702) to Bartha and (sic) Madzer, issued in 1913, containing an exposition of the same features. Neither Degn nor

Pollacsek mentioned stability and it is therefore clear that they were as oblivious to the full importance of their designs as have been most of their successors.”

It is interesting that patent-expert Platt cites the work of Degn, Pollacsek and of Bartha/Madzsar (he apparently was unaware that K. Pollacsek was an English patent attorney for Hungarians Max Bartha and Dr. Josef Madzsar), the latter of which are discussed by Liberatore.¹⁰⁴ The work of Paul Frederick Degn, of Bremen, Germany, however was even then, if not now, obscure, and may be found in the American version of his patent, # 922,756 signed September 23, 1908 and patented May 25, 1909.¹⁰⁵

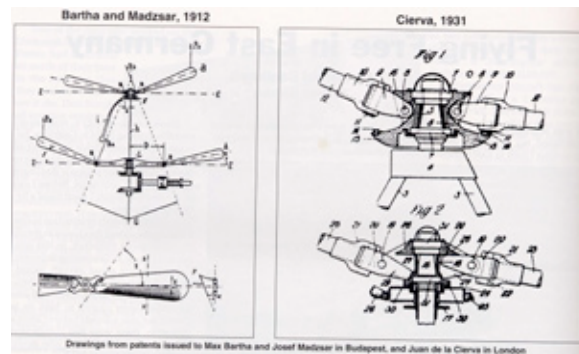

Platt goes on to comment on Cierva, observing that:

“It is a curious commentary on the confusion of helicopter development that de la Cierva, who contributed so very much to the mechanical perfection of the articulated rotor, conceived the autogiro under what is now seen to be the mistaken belief that torque reaction was the insoluble problem of the helicopter. The Focke machine by using the same rotor arrangement as many of the earliest helicopter designs, an arrangement in which there is no external torque reaction, shows that torque in reality was never an obstacle to success, at least in the first development stage. Furthermore (sic) Cierva, having avoided the positional stability problem by designing a machine which required motion for support, proceeded to conceive independently and to develop extensively the articulated rotor for other purposes, without ever having come to the realization that it contained also the true solution to the

problem which he had given up as insoluble.”¹⁰⁶

Platt’s discussion of the present centered, understandably, on the Focke helicopter, focusing on a slide of its rotor head. He stated to the audience: “The idea of variable pitch has become well known through its use in airplane propellers. In the helicopter it is even more important because of the wide divergence of pitch requirement between full power flight and power off autorotation. The type of mechanism used by Focke for this purpose is one which links blade lag to blade pitch. Increased torque, by causing the blade to lag, automatically increases the pitch and vice versa.”

Platt predicted that “future helicopter development will follow lines laid down in the past by airplane development. . . the Focke helicopter is open to great improvement in three ways: 1. Increase in aerodynamic lift efficiency, 2. Reduction of structure weight, and 3. Reduction of parasite drag. He also saw a question in two rotors vs. one: “In the case of the helicopter . . . the theoretical gain of the single over the double rotor appears to be much more pronounced than is that of the monoplane over the biplane. . . . Concerning structure weight, the advantage is again clearly on the side of the single rotor which does not require outriggers and long drive shafts.” These comments must be viewed as somewhat ironic given that the Platt-LePage XR-1 (PL3), funded by the Army with Dorsey-Logan funds, was a twin-rotor design along the same lines as the Fa-61.¹⁰⁷

Klemin then took the podium and, in contrast to his previous remarks at the end of Gerard Herrick’s presentation, literally heaped praise on Platt when he said: “I think, gentlemen, Mr. Platt’s paper is particularly illuminating, in respect of the stability with flapping rotor. This is the first time that I have felt the flapping rotor was an inherent solution of helicopter stability, that is the first time that I have seen a simple theoretical demonstration of the fact. *If the rest of the meeting isn’t worth anything – and of course it is worth a lot – just to see that first diagram and the first outline of the stability of the helicopter is a very valuable contribution, Mr. Platt.*” (emphasis added)



(Rare photo of Platt-LePage Helicopter during construction – courtesy of Jay Brian Hendrickson, W. Laurence LePage Archives)

Klemin then singled out Professor Montgomery Knight of the Daniel Guggenheim School of Aeronautics of Georgia Tech (renamed the School of Aerospace Engineering in July 1962), which had been founded with a \$300,000 grant from the Daniel Guggenheim Fund for the Promotion of Aeronautics in 1930, and which had begun classes and research activities¹⁰⁸ in September 1931 with two dedicated faculty members and eighteen students. Knight was the first chair of the school, serving until he died in 1943. In 1967, the university constructed a modern building on the site of a demolished model shop – it was named the Montgomery Knight Building. Knight, who was to make a presentation later during the meetings on helicopter research at Georgia Tech, declined to add anything to the presentation, but he did knowingly comment on the current status of helicopter research in stating: “The recent development towards the successful helicopter in this country is so new, there are relatively few places where serious investigation and study are being carried on. It is encouraging to me, as being in one of these places, to know there are other places in the country, if only a few, where this work is going on.” But then Knight went on to add, perhaps with some insight as to why Chairman Klemin had singled him out to respond to Platt’s presentation, “[i]f I am supposed to pick an argument with Mr. Platt, I don’t believe that I can afford to do that.”

Short questions followed from a Mr. Brye¹⁰⁹ and Gordon B. Jackson, and then Chairman Klemin cut the session short, asserting the necessity to move to the next presentation, and even though it involved a competing rotary-wing technology, it occasioned the a wonderfully warm and praiseworthy introduction of E. Burke Wilford: “[t]he next speaker has devoted so much time to the

preparation of this meeting that I am afraid it would be ungracious of us to deprive him of the remaining time before adjournment. Mr. Wilford, I am not going to shower (sic) eonconiums [presumably the speaker intended *econiums*] on you or say what a clever engineer I consider you to be. Everybody knows Burke Wilford, knows him as a swell engineer and a good fellow, and loves him, and that is the best introduction I can give to our Chairman.”

Wilford’s paper/presentation was entitled “The Gyroplane”¹¹⁰ and he began with a summary of the development of the Wilford Gyroplane¹¹¹ with yet another swipe at Gerard Herrick. Wilford said: “I am afraid I will not be the humorist that our learned Mr. Herrick is, for I have a real fight talk to give you.” And although it is impossible to know if as intended, it is likely that, given the focus on the Wilford Gyroplane flying, this is a misprint, and he actually announced a “flight talk”. His presentation centered on the work of Walter Rieseler and Walter Kreiser (discussed *supra*) which would not have been as familiar to the audience as that of Cierva and Pitcairn (hence Wilford aircraft, not derived from Cierva’s work, were properly denoted as a ‘Gyroplane’ and not Autogiro).¹¹² After constructing a gyroplane in accord with the principles of “rigid blade feathering” of the European inventors who had licensed their patents to Wilford, the resulting aircraft was first flown by Paul Hov-gard¹¹³ “now with the Curtiss Company”, who would later present a paper to the meeting participants. Additionally, Wilford also acknowledged the participation of Elliott Daland, who would later write on the Wilford Gyroplane.¹¹⁴

After describing the flight trials of the Wilford Gyroplane, Wilford shared two visions of the future with the audience. One was a streamlined version of the Focke Helicopter which he called the Heli-Gyro while stating “[w]e are not trying to copy Mr. Focke’s word in any way, but I am just interested in seeing that rigid feathering blades are used in the helicopter field as well in the gyro field.” Additionally, Wilford looked twelve years into the future and imagined that:

“I am a great believer in Mr. Herrick’s principle of the Convertiplane . . . [h]ere is something, say in 1950 we will be going to Europe in. It is a clipped wing aeroplane, with 10,000 horsepower, gross weight we can not estimate because they’ll be using Beryllium alloys which will improve all the weight figures immensely. It has just

enough wing area to support it at 250 miles cruising speed, so that you design the most efficient ship just to fly. You don’t worry about landing. Then, we put Ralph McClarren’s maple seed on top, and we have take-off and landing.”

Wilford’s future convertiplane would not, in fact, fly until 1957 – the Fairey Rotodyne, but his description is essentially, if broadly-brushed, correct. But the Wilford presentation also a discussions of the relationship between rotor tip speed and aircraft speed. Wilford stated during his presentation:

“In order to maintain aerodynamic efficiency the rotor must be either convertible to fixed wing area for forward flight, allowed to idle or be retracted into the fuselage. For there is a reason to believe that a limit of speed may exist in rotors alone due to the approach of tip speed to the velocity of sound so that aircraft supported by the rotor is limited to approximately 200 miles per hour. If the rotor is suppressed and the aircraft flies on the clipped wing is only limited by the drag of the machine and the horsepower available. A good inherently safe aircraft should be able to make a forced landing in a woods or on a mountain side without any reduction in the high speed, performance, and useful carry capacity.”

Chairman Klemin could barely contain his enthusiasm for the presentation, particularly as Wilford had given a mini-presentation within his main topic on “Inherent Aircraft Safety” and sketched a future of safe and convenient flying via means of an aircraft that could combine the efficiency of fixed wings with the convenience and safety of rotary-wing flight – the convertiplane – Klemin positively enthused “That’s the way to do it. All this half-way stuff and mathematical statements, don’t do us any good. This is the way to do it.”

Klemin then called on Grover Loening,¹¹⁵ who had sold his Loening Aeronautical Engineering Corporation in 1928 to Curtiss-Wright for \$3,000,000 and who would, after becoming a major investor in Grumman, become and remain an aviation consultant, even participating in the design of the helipad on the top of New York City’s Pan Am Building. Klemin was interested in hearing from “one of our most distinguished aeronautical

engineers” who had actually seen the Focke–Wolfe helicopter, noting that the “other gentlemen are accustomed to talking of it at second hand, or from pictures.” Loening, presumably an old hand at attending meetings, and knowing of the importance of the coming lunch, answered none-the-less with a declaration that conveyed the perceived import of the German helicopter, when he answered: “Well, as we are all very hungry, Mr. Chairman, I will briefly say that it is quite a shock to an old heavier than air craft designer, to see this heavier than air craft hover in the air, so easily that the pilot, going up six feet, leans over to Professor Focke and says, in a loud voice, “Vas Zoll ich jetzt then?” (What shall I do now?), and proceeds to converse with him while he is suspended in the air. That was the most graphic illustration of what it really amounts to.”

Klemin then recognized Professor Montgomery Knight, who had earlier refused to challenge Haviland Platt, but did not hesitate on this occasion. He stated in a telling and ultimately prescient comment in response to Wilford’s presentation:

“I don’t know whether I was supposed to take issue with Mr. Wilford, but I am going to take the liberty of doing it. The (sic) parameter of forward motion to rotational speed, which Mr. Wilford was referring to has values in the present autogiro as high as five tenths – not three tenths, but five tenths, -- and there is a mysterious, unexplored region beyond that point that frankly, we know nothing about. Theoretically, of course, we can carry our mathematics up to indefinite values of very high parameter, but there is still much work to be done in the wind tunnel, and recent experiments that I have had in the wind tunnel studies on this subject have revealed that for the helicopter, particularly where the initial blade angle is larger, one must step with caution into that region, for fear of stalling the retrieving blade [probably ‘retreating blade’], and having the model come to pieces. That actually happened once in my experience, and it was quite distressing, particularly since I had just stepped out of the disk of the rotor a few seconds before. So there I would like to make that one suggestion, that we can already, in the autogiro, go up to values of

parameter of five tenths, and we may be able to go higher, even, with helicopters. There is a fertile field of investigation there.”

And indeed, Knight’s prediction has proven correct, give the growing body of research in the area of the convertiplane helicopter configuration.¹¹⁶ And with Knight’s comments, the first session ended.

The Second Session – Friday Afternoon, October 28, 1938

E. Burke convened the afternoon session to introduce its designated Chairman, W. Wallace Kellett,¹¹⁷ with a reference to an ascribed role in the recent passage of the Dorsey [Logan] Bill, in stating: “Gentlemen, our Chairman this afternoon needs no introduction. He only spent six months in Washington last year, to get the Dorsey Bill passed, and besides that, we wouldn’t be here if that hadn’t passed.” And while this description was obviously intended to be flattering, it resulted in Kellett’s taking exception. He replied: “I don’t know how to take that introduction. I spent some time down in Washington to show some of our members of Congress our ship and some of the needs of this type of aircraft, but I don’t think I can take any responsibility for it. There were a great many other factors in it than that. So I will let that go by, with that reference.” And with that, Wilford retreated with “I am sorry if I said the wrong thing” and the session properly began, but it did not go smoothly.

Kellett noted:

“The first speaker today isn’t here yet. He happens to be a Congressman, and Mr. Dorsey, the one who is responsible for the legislation. I think we have a very good program. I won’t undertake to tell you that we have the most important part of the program today, but I have no hesitancy in saying that the gentlemen who are going to express their views here in this afternoon’s meeting are among the most important wheels that make the car run. . . . We are going to start the meeting by hearing from Lieutenant Gregory . . . [who] represents the United States Army and the War Department . . . one of our customers. The War Department has invested money in rotary wing aircraft, and they expect to

get utility out of rotary wing aircraft, and everything we think about in our design and research work should always be with the idea of supplying something that is going please that customer, and give him the maximum for the money he spends. So I won't say any more, but that is the basic principle. I feel very strongly that we are only serving our customers, and we have got to produce from the very beginning to the last, something that is going to be of actual value to our customers. I might say that Lieutenant Gregory and Lieutenant Nichols^[118] were the original Army Air Corp pilots assigned to the autogiro when first obtained. They went into this thing without every having seen an autogiro, and everything that has been done there is to their credit. They conducted a flight school at Wright Field last year and trained pilots and mechanics. They did a job that I am sure everybody in our organization feels couldn't have been done any better by anybody, and frankly speaking, I would say that we might not have done as well."

And with that flattering introduction H. Franklin Gregory, 1st Lt., began his presentation entitled "Army Experiences With Rotating Wing Aircraft"¹¹⁹ but if Kellett had been privy to Gregory's thoughts on the Autogiro, the introduction might not have been so laudatory.

Kellett had provided the Air Corps with a test version of its direct-control Autogiro – the military version of the KD-1/KD-1A, the YG-1 series (YG-1/1A/1B). It was first delivered to the Army Air Corps in October 1936 and performed well enough the subsequent models were ordered for the Air Corps Autogiro School at Patterson Field in Springfield near Dayton, OH in 1938. Subsequently, the KD-1 flew in a testing program with the Field Artillery Board at Fort Bragg, North Carolina consisting of directing artillery fire, reconnaissance, and landings in otherwise inaccessible areas. That testing, including the first use of a telephone, with a 1500 ft cord from the ground, to an aircraft is recounted in H. Franklin Gregory's *Anything a Horse Can Do*. The second Kellett aircraft, a YG-1A, which had been modified with addition of military H.F. Radio, was delivered in October 1936. And while the testing showed a reconnaissance role in artillery spotting for the

aircraft, each of the test models would suffer multiple crashes and would eventually be destroyed in the testing process, in the field or in the N.A.C.A. wind tunnel, but the Army would open its Autogiro Training School. But as then 1st Lieutenant (later Brigadier General) H. Franklin Gregory makes clear in his autobiographical book *Anything A Horse Can Do*, he and his army colleagues were *even then* viewing the Autogiro as an intermediate step towards an aircraft that could truly hover, the helicopter. He wrote:¹²⁰

"The greatest trend that occurred, however, was not with the Autogiro. Nor with the results of the school, but with a nationwide interest in private flying . . . It didn't take the Army experts long to realize that some of the small aircraft like the Aeronca, the Piper Cubs, Taylorcraft, Interstates, and Stinsons would do almost the same thing in the air that the Autogiro could accomplish. The light planes were far cheaper. Tests were run with these craft in liaison problems with the ground forces during maneuvers. Results were very encouraging. . . .

In truth, this had been done years before the advent of the Autogiro in the Army, since we had the famous Curtiss Tanager, winner of the Guggenheim Safe Airplane competition in 1929^[121], which could fly as slow as thirty miles an hour, about the same as the Autogiro. Yet in the Autogiro we had seen a way to vertical flight and to many of us it seemed the next step toward the helicopter. Primarily this was the reason for the Army's gyro school and its exhaustive research into rotary-wing aircraft. Thus one of my main tasks in the new job at Wright Field was to look for a successful helicopter."

Gregory had concluded his evaluation of the Kellett direct-control (but not jump take-off) Autogiros that they were "in reality little more than a high-lift device on a conventional airplane . . . that offered no more – and in many cases less – performance than the performance of many ultralight fixed-wing aircraft."¹²² And it was these opinions that constituted the background of his presentation.

Gregory's presentation began with the telling of what today would be characterized an

unacceptable racial epithet – made not the whit more acceptable in conceding that 1938 was a different America and the audience was probably all Caucasian – this was, after all, an historic aviation meeting, not a gathering of the local Klu Klux Klan. And while Lt. Gregory was quick to note that he was “not a speaker . . . not a mathematician or an engineer” who “just purchased me a slide rule outside”,¹²³ he was perhaps deliberately minimizing expectations for his “twenty-minute paper on army experiences with rotating wing aircraft.”

But then he noted that “when I received a program, I noticed by dividing two hours by the number of speakers, that I had only fourteen minutes to present this paper, so I began to get worried, particularly since I had a film that I wanted all of you to see.” And yet, given the time imperative that Gregory had just announced, he paused for a curious Janus-like story:

“I am reminded of a story that Major Carl Green told me last night. He said that one man walked up to another and said, “Both-er can you give me a quarter to buy a cup of coffee?” The man looked at him and said, “A quarter! My gracious, I could buy five cups of coffee for a quarter. If you would ask for a dime, I might give it to you.” He said, “Now listen. I asked you for a quarter. If you want to give it to me, O.K. If you don’t want to give it to me, O.K. But don’t try to tell me how to run my own business.”

On one level, Gregory was stating that, as a non-speaker-engineer-mathematician, he wouldn’t tell the meeting participants how to do their business; but at the same time he was also telling them not to tell him how to do *his*, in this case, *his country’s business* – and that business was, in his own words, “to look for a successful helicopter.”

Gregory’s account of the military experience with rotary wing-aircraft began with a reference *en passant* to the Army investigation of the obscure Peter Cooper Hewitt Helicopter of 1918¹²⁴ (note – according to Liberatore this was the 1917 Crocker-Hewitt Helicopter, a co-axial design),¹²⁵ the even more obscure “J. E. McWorter “Auto-plane” helicopter,¹²⁶ and the de Bothezat helicopter.¹²⁷ Gregory then proceeded to summarize the Army’s involvement with the Autogiro which constituted the bulk of its rotary-wing aircraft experience. This encompassed flying with the Field

Artillery School, the Infantry School, with the Cavalry and the Air Corps Autogiro School.

He concluded: “Well trained pilots are necessary for the operation of the present auto-giro. The autogiro in the hands of an expert is probably as safe as the conventional airplane. *I didn’t see any tomatoes come this way.* (Laughter) The stability is comparable to that of an airplane. Tests now under way indicate that the autogiro *may* develop into an extremely useful military instrument, particularly adapted to certain observation and other needs in Army cooperation.” (emphasis added)

It is obvious that Gregory knew he was throwing down the gauntlet – and this is understandable given his (and apparently the Army’s) sentiments even then favoring development of the helicopter.¹²⁸ In asserting that the Autogiro required well trained and expert pilots, he was directly challenging the belief and advertising pitch of Pitcairn’s Autogiro Company of America that portrayed the Autogiro as the ‘safe aircraft for the masses,’¹²⁹ (a claim later made with deadly results by Igor Bensen for his Gyrocopter).

Chairman Kellett, perhaps in an attempt to graft a more positive ending to Gregory’s presentation, proceeded to call upon the Lieutenant’s superior officer Major Green who was in the audience, asking if he would like to add anything more? Instead of adding anything, Major Green reinforced Gregory’s unique credentials, stating that “His [Gregory’s] experience is unique, in this gathering, because he is, I would say, one of the first persons to actually make application, service application, of this instrument. He runs a school, graduated two classes, he has kept his autogiros in commission, he has had no accidents. The school has been a great credit to Lieutenant Gregory and Lieutenant Nichols, and to the manufacturers of the auto-giros.”

Gregory, perhaps sensing that his presentation had not risen to the level expected occasioned by Kellett’s laudatory introduction, intervened to praise the Autogiro’s ability to be concealed beneath camouflage nets in a small clearing in which Nichols had landed. Kellett, apparently unappeased, then sought to get an opinion from Lieutenant Eric S. Nichols, but if the erstwhile Chairman thought to gain a more favorable view of the military Autogiro, he received faint and fairly vague comfort as Nichols succinctly added: “I have had a lot of fun with the autogiro and a lot of difficulty with it, and through it all, I am most enthusiastic on its military possibilities.”

Kellett, not giving up in his attempt to get an addition to Gregory's presentation, turned to F. J. Bailey of the N.A.C.A., who declined as he was to speak later in the meetings, but who did reply in a somewhat dark tone "[o]ur experience was rather unfortunate in the full scale tunnel . . . " leading Kellett, in an attempt to blunt the thrust (no pun intended) of the previous statements, to opine "I think we have made the giro outstanding. We have not only wrecked it in the air; we have done it in the wind tunnel." And while Kellett apparently did not trust the floor to open the presentation for questioning, allotted the remaining time to allow Gregory to show a movie the graduation exercises of the Army Air Corps Autogiro School (during which W. Wallace Kellett had presented each pilot with a "miniature autogiro mounted on a plaque for desk use, very nice and appreciated by all."

Kellett then introduced the main speaker who had been delayed, Congressman Frank J. G. Dorsey, although Kellett's introduction got a bit befuddled and he certainly managed to convey an opinionated (but probably not uncommon) view of the government in Washington. Kellett stated:

"Our next speaker is Mr. Dorsey. I think that name ought to mean a great deal to everyone here today, because Mr. Dorsey who had the foresight to see that the development of rotary (sic) wind aircraft should be carried on as part of our national resources. He had the interest in it to go to work and dig into it, find out what it was all about, in addition to all the other things he has to do in Washington; He had the courage when he developed a definite program, to work with it and see that it was enacted, which resulted in the enactment by Congress in the last session of the Dorsey Bill, authorizing \$2,000,000 for autogiro—excuse me, rotary wing aircraft—development. Down in Washington, I did take my ship there and demonstrate it to some of Mr. Dorsey's colleagues, and I did get to know some of his fellow members of Congress. I don't know how many of you have ever been close to a real, live Congressman. We've got one here, and I think when you have heard him and got to know him in that way, that you will feel that you want to go home and get acquainted with your Congressman, because I have found in Washington that our

country is run by Congress and Congress is run by committees, and members of those committees. When they are in Washington, they spend about 10% of their time helping their constituents at home, they may spend another 10% of their time helping in the affairs of the party to which they belong, and the other 80% of their time is spent in running this country of ours. They are just as interested in the problems that we have as they are in anything else --- well, I can't finish that. They are interested in the country. So I will turn the floor over to Mr. Dorsey, the fellow who took us out of the orphan asylum. If I didn't have to be dignified, I've heard it called other things."

And there can be little doubt that many in the audience viewed Dorsey as the 'savior' of the rotary wing aircraft due to his actions in advancing what came to be known as the 'Dorsey Bill', and which would be signed by President Roosevelt as the Dorsey-Logan bill after Senator Logan had sponsored it in the Senate, but although perhaps not obvious at the time, that bill would not benefit each of the leaders of that industry in attendance equally.

With the growing belief that war would come to Europe, Harold F. Pitcairn had become convinced that the military needed to develop rotary wing aircraft, and saw such support as vital and necessary to the aluminum PA-36 direct control jump takeoff Autogiro¹³⁰ then under development, so it was logical to turn to an aviation-knowledgeable and sympathetic member of the Pennsylvania congressional delegation, Representative Frank J. G. Dorsey. Pitcairn may also have been guided in this effort by his older brother Raymond who was exceptionally well-connected¹³¹ in the political world of the day. Pitcairn requested that the congressman sponsor a bill to fund experimental Autogiro development *for the military*, and after drafting, introduced H.R. 8143 in early 1937, thereafter known as the Dorsey Bill. The bill, reflecting the *specific* concerns of his constituents,¹³² which included the Kellett brothers, E. Burke Wilford, and Gerard Herrick (but not Platt and LePage who were well out of the mainstream in terms of their technology, finances and community standing)¹³³ was titled "To Authorize the Sum of \$2,000,000 for the Purpose of Autogiro Research, Development and Procurement for Experimental Purposes."

Congressional hearings by the House Committee on Military Affairs were scheduled early in 1938, and Pitcairn resolved to have a flying model of the PA-36 ready to convince the legislators. The Kellett Autogiro Company expressed great interest and it was apparent that the two would be rivals for the government funds. Kellett had, after all, already received a contract to supply seven KD-1s, dubbed YG-1A/B's by the military, to the Army Autogiro School, established on April 15, 1938 for pilot training and field testing under the direction of 1st Lieutenant H. Franklin Gregory at the same time that Pitcairn had closed his production line. This rivalry had been simmering for several years as Kellett rankled over the superior position of the Autogiro Company of America as the Cierva licensing agent and patent repository in America, and Pitcairn resentment at the Kellett independent consultations with Cierva on direct-control. And there was the lingering issue of the international sales of Kellett K-3s – Pitcairn continued to maintain that this was a violation of the ACA licensing agreement, but more importantly and of greater relevance to the pending legislation, Harold Pitcairn felt that the Army testing of K-3s was not in the best interest of the Autogiro. Pitcairn had a not unreasonable belief that the future of Autogiro technology would be better demonstrated by what he termed the “third generation” – the direct-control, jump take-off PA-36 (in fact, as they Autogiro school was made up of the military version of the Kellett KD-1 direct control Autogiro that could not accomplish the jump takeoff, H. Franklin Gregory's Autogiro experience was not, nor would it become with the coming of the helicopter, state-of-the-art). It was not surprising, then, when it had become known Kellett company was also working on the collective-pitch control system necessary for jump take-offs under the direction of its chief engineer Richard H. Prewitt.¹³⁴ He had previously visited with Cierva in late 1933 to discuss direct-control, a meeting viewed with continuing suspicion by Pitcairn and his associates. Harold Pitcairn had always taken legal steps to protect his discoveries and patents, and he now took other steps made necessary by the perceived rivalry – engineers were admonished to exercise caution over the efforts – all papers accounted for at the end of the day, locked desks and safes were the order of the day, and all public statements had to be screened by legal counsel, approved and then only repeated, not elaborated upon. No hints that might help

the Kellett engineers were to be given, even in a casual conversation.

Agnew Larsen had been placed in charge of the PA-36 development program, and he expressed confidence that he could build the prototype for \$50,000 by the time of the Dorsey Bill hearings. He would be proven wrong on both counts. Jim Ray, still in England, had asked to return to America, but the company, with no flying prototype, had no piloting work and Pitcairn felt it would be a more productive effort for Ray to continue gathering information on European rotary flight developments. It was an effort that, as discussed *supra*, resulted in Ray's dismissal from the company as he came to advocate helicopter technology over the Autogiro.

The Dorsey Bill hearings began on April 26, 1938 and Harold Pitcairn had meticulously prepared a booklet illustrating Autogiro development and touting the PA-36 as the latest model. But he had misestimated the sentiments of those who appeared before the Committee and severely misread the results. The hearings would prove a disaster to the future of Autogiro development in America, but that was not known at the time of Dorsey's presentation in Philadelphia in October 1938.

There is no doubt that those who testified during the two days of Dorsey bill hearings were influenced by the images from a few months earlier of Hanna Reitsch flying the Fa-61, and this clearly showed from their comments. Assistant Secretary of the Navy, Charles Edison, flatly stated that the Navy, having already evaluated the Autogiro, was not interested in rotorcraft unless they possessed ability to hover. And then Professor Alexander Klemm, Dean of the Guggenheim School of Aeronautical Engineering of New York University, who had made known a favorable view of the Autogiro, cited the recent Hanna Reitsch Fa-61 flights and ventured the seemingly innocent opinion that the Dorsey bill language use of the word “Autogiro” might reasonably be construed to include all types of rotary wing aircraft. And, he added, that being the case, perhaps this implicit meaning should be directly stated to include all such rotary wing aircraft. No one present, especially Harold Pitcairn, took much notice of this redefinition of the bill's terms, but the inclusion of all types of rotary wing aircraft would now encompass helicopters, surely relevant to 1st Lieutenant Gregory, who was of such a lowly rank that there was no possibility he would be called to testify before the Committee. But he was

perhaps the most experienced Army officer in rotary wing aircraft based on his experience with the Army Kellett K-3 models, and his relatively junior officer status had not prevented the Army from assigning him to command its Autogiro School,¹³⁵ nor would it prevent his subsequent assignment (after being promoted to the rank of Captain) to administer allocated funds.

Witness after witness, citing potential uses, enthusiastically testified as to the benefits of rotary wing flight, and by the time that Harold Pitcairn appeared it was apparent that the Committee members were favorably disposed to the Dorsey Bill. As it was near the end of the second day, Pitcairn's testimony was highly abbreviated and, placing his prepared Autogiro booklet in the record, he soon left after answering a few questions, apparently satisfied with the results. But he failed to understand the gravity of the opinions that had emerged, namely that rotary wing flight would be of benefit, not specifically *Autogiro* flight; and he further failed to realize that two of the specific questions asked were seminal to a far different result than he had anticipated. He had admitted to the Committee that he had spent \$3,250,000 in Autogiro development since 1928, and that the PA-36, the end product of that investment, did not even yet exist in prototype. Although he was apparently satisfied with the hearings, it is clear that the final impression was that while rotary wing flight would prove of benefit, those benefits were not likely to emerge from the Autogiro. It is not surprising, then, that the Committee took only ten minutes after the close of the hearings to change to purpose subtitle – the words “Rotary Wing and Other Aircraft” were substituted for “Autogiro” -- and while this substitution may have seemed innocuous, it would doom the Autogiro for Lieutenant H. Franklin Gregory would insure no government money would flow to the Pitcairn PA-36 development or procurement from the Dorsey Bill, which was passed by the House, sponsored by Senator Logan in the Senate, and signed into law by President Roosevelt as the Dorsey-Logan Act on August 1, 1938, but which funds were reduced to \$300,000 in Public Act #61 passed by the Seventy-sixth Congress and House Appropriations Committee.

But in October 1938, it was clear that Dorsey was both enjoying his notoriety before the rotary wing aircraft audience and basking in his apparent legislative success for his constituents, and his talk reflected that sense of success even

though he began with somewhat of a confusing declaration when he stated that “something must have gone wrong with this rotor today, because in the original letter from the Institute, I was advised that I was to talk on the military uses of rotating wing aircraft, and looking at the program today, I see that I am to talk on “Government Use and Development”.[¹³⁶] Well, now, that just lets me out this afternoon. I can talk about anything I desire.” This *is* confusing because Dorsey is, as observed by a later speaker John M. Miller, speaking from a written speech, and he does go on to speak on government uses and development. Dorsey's verbal maneuver *may originate* from his desire to posture before his Autogiro-advocating constituents, most notably the representatives of the Kellett and Pitcairn companies, for by citing an original invitation to speak on ‘military uses of rotating wing aircraft’, he was undercutting the previous speaker on the military experiences with the Autogiro, Lieutenant Gregory, who had just stated (to the consternation of Chairman Kellett) that fixed wing aircraft in general aviation were approaching the slow flight performance of the Autogiro. And Dorsey continued this effort, letting the audience know of his intent by direct reference to Gregory's talk with (emphasis added) “I was quite interested in the remark, and *I didn't have any tomato to throw at the time*, -- the remark of Lieutenant Gregory about the safety of the conventional type aircraft.”

Dorsey, in his ‘verbal tomato’, proceeded to recount at some length his near disastrous experience in a fixed wing aircraft encountering turbulent air, segued to his prepared speech with the declaration that “I thought there surely must be some kind of an aircraft can keep you in the air, or let you down on the top of a tree somewhere without cracking everybody up. So I became interested in the subject, and I just want to express a few thoughts to you this afternoon concerning what part the government should play in the development of rotating wing type aircraft, and what you can do to assist such a program.”

This was, admittedly a subtle but extremely clever way to begin a discussion of the how's and why's of government support – by linking, however indirectly, such support to aircraft safety, for that was exactly the theme espoused for most of the 1930s by the Autogiro Company of America – its advertising copy reverberated with the claims that anyone could learn to fly an Autogiro and that it was the aircraft that “knows its own way down”¹³⁷ and it is now conceded by the Pitcairn Aircraft his-

torian Carl Gunther that the Amelia Earhart August 1931 article "Your Next Garage May House An Autogiro" in *Hearst's International combined with Cosmopolitan*¹³⁸ was actually authored by the Pitcairn ad agency copywriters.¹³⁹

Dorsey proceeded to provide a laundry list of reasons why the government had a stake in supporting rotary wing aircraft development, probably to the satisfaction of those in his audience – but, given subsequent events, the champions of the Autogiro would have considerably less reason to feel in such a manner, while those advocating advancement of the helicopter could not possibly know that their course would be considerably brighter. And perhaps even Dorsey was unaware of what the future would bring for Pitcairn, Kellett, Wilford and Herrick – at least his sincerity was unquestioned and unquestionable, even as the vision of future government support might have been. Invoking historical example and, by extension, analogy, beginning with official aid given to Samuel F. B. Morse to aid development of the telegraph, and extending through a brief description of how government funding vis-à-vis airmail routes/post office grants nurtured the growth of America's passenger airline system, Dorsey arrived at the following points (capitals in the original):

NOT AN IMPORTANT PURCHASE OF AIRPLANES HAS EVER EXISTED IN THIS COUNTRY WHO DID NOT HAVE BASIC FINANCIAL BACKING FROM THE FEDERAL TREASURY.

NO MANUFACTURER WHO HAS CONTRIBUTED ESSENTIALLY TO AVIATION PROGRESS IN RECENT YEARS REMAINED IN BUSINESS WITHOUT ORDERS DEPENDENT ON FEDERAL INTEREST.

THE PRIVATE MARKET CANNOT SUPPORT AVIATION EXPERIMENTATION AND DEVELOPMENT.

He then cautioned: "The men behind the American rotating wing aircraft industry will do well to ponder these inescapable conclusions." but then added "Fortunately, most of you have already done so and acted upon your thinking."

Dorsey was walking a fine line, but he was doing it superbly for his audience! He knew that

Pitcairn had admitted before Congressional hearings debating the Dorsey Bill that he had spent over \$3 million dollars¹⁴⁰ with little commercial success. And the public had increasingly become aware of the large number of non-fatal¹⁴¹ Autogiro accidents.¹⁴² Dorsey dealt with each of these facets in a form that was elegant *and* efficient. With regard to the former, he absolved them with: "The two pioneers, the Kellett and Pitcairn companies, made a valiant try. I suppose they knew they had something good, and something highly attractive to the private pilot who wanted safety and elasticity in his flying operations. In 1931-32 they went to the country with their Cierva model autogiros¹⁴³ and sold about 85 ships. "Then," Dorsey continued, seemingly unaware of Pitcairn's deliberate withdrawal from the market in anticipation of the development of direct control that would obsolete the older models,¹⁴⁴ "the market dried up." With regard to Autogiro accidents, he opined that "[i]t was by no means wholly the fault of the giro, although performance in the hands of every Tom, Dick and Harry was not always so good as the companies' own flyers were turning in." He concluded with "[t]he key fact is that then and today, the private market is limited for any type of flying machine and seems likely to stay within sharply defined limits for some time" and then described how he introduced what became known as the Dorsey Bill, HR 10605.

Dorsey advised the rotary wing aircraft developers to pursue three markets: "military and civilian procurement programs of the government; the airmail service, and the restricted but growing private market" and noted that the companion HR 7448, the Haines Air Mail Feeder Bill, authorized an "experimental autogiro feeder mail line"¹⁴⁵ which would become a reality during the July 6, 1939 – July 5, 1940 time frame from the rooftop of the Philadelphia 30th Street Post Office initially with John M. Miller, who would speak later that day, as pilot later aided by Assistant Pilot Frederick "Slim" Soule.¹⁴⁶ He also referenced that "the War Department has called for suggestions, recommendations, proposals and requisitions from the 20 bureaus and departments, as specifically called for in the Dorsey Act. . . . Following study and consolidation of these reports, decision on the immediate program will be made and it is expected the War Department will call for a variety of proposals and development programs. This step will depend on the availability of funds, to be derived from forthcoming appropriation allotments."

However, it would not work out as Dorsey anticipated. By the time the War Department convened a meeting of interested constituencies to define the Dorsey-Logan Bill rotary wing aircraft criteria on May 31, 1939, two events had intervened. War had come to Europe on September 1st with the German invasion of Poland and the House Appropriations Committee had designated the Army as the administrative agency, and the Army had in turn appointed Captain H. Franklin Gregory as its administrator. Gregory, in turn, familiar with the rotary-wing developments of Pitcairn, Kellett and now Sikorsky, had become convinced, and informed his Army superiors, that the future lay with the helicopter.

As a consequence, the Circular Proposal stating aircraft requirements, the first step in the allocations process, was drafted by Gregory in consultation with officials from various government agencies that had vested interests in rotary aircraft including the Departments of Agriculture and Interior, survey agencies,¹⁴⁷ N.A.C.A., and the Army and Navy which were derived from the submitted proposals and discussions of the September 1939 meeting. That meeting was conducted by Colonel C. L. Tinker, in the absence of General Henry H. "Hap" Arnold, then Chief of the Army Air Corps, on May 31, 1939. The assembled officials¹⁴⁸ agreed, prodded by the expert briefing supplied by Captain Gregory, who was the junior officer present but who had become project officer for all the Army's rotary-wing aircraft, that the proposed Dorsey-Logan rotary-wing aircraft should be able to make a vertical take-off over a 50 foot obstacle. At the time only the German helicopter could achieve such performance, a fact certainly known to Gregory, and to all intents and purposes this flight requirement eliminated the Autogiro. The United States was 15 months away from officially entering the conflict and Gregory was even more convinced that the future of military rotary-wing flight lay with the helicopter, not the Autogiro.

But this was still in the future and Dorsey optimistically proceeded to outline his vision of military roles for rotary wing aircraft, quoting various military officers who cited used for the Autogiro, understandably as no one had seen a helicopter in America other than in films of the Focke aircraft. Dorsey asserted that such anticipated government funding could not have:

"[W]on favorable congressional action a single day before it did" Dorsey claimed

that "[b]efore it could be approved, the Army had to fly the autogiros which had been purchased from the Kellett Corporation. The lengthy studies of Pitcairn and Kellett models at the N.A.C.A. laboratories had to be made. Members of Congress who are themselves authorities on aviation made it their business to see what the rotary-wing manufacturers had to offer. Departments such as Agriculture and the Navy purchased ships, tested them, put them into use and reached conclusions. Bureaus such as Forestry and the Coast Guard borrowed giros to make tests for their special need. Committees of the House and Senate took testimony from all quarters to determine at last that public welfare and the national defense would benefit if the rotorships came into their own use."

He then stated, as valid then as today, that: "The federal government cannot be a profligate sugar daddy, a careless angel backing uncertain, untried proposals. As American citizens, we should be proud this is so. As a member of Congress, I shall always insist that it be so." His conclusion appears sincere: "For these very reasons, I am proud of the part I played in obtaining federal assistance for the rotating wing aircraft industry. I have faith in the judgment of those high-ranking officers, soldiers, expert public servants and able air-men who tell me your whirling blades have an important place in the air. I congratulate you on your past efforts and successes, your courage and your vision. To wish you well for the future."

As Congressman Dorsey had referenced potential government use, Kellett first called upon John Easton from the CAA who noted that "the Civil Aeronautics Authority has handed to the Secretary of War a program which we feel if he approves it, and we get the money to carry it out, will give definite assistance to rotary wing development with regard to civil aeronautics, as distinct from the military value. This has gone forward, and I hope we get the go-ahead." And while this was optimistically stated, and the CAA represented at the September 1939 meeting by Easton, the prospect of war crowded out civilian applications of rotary wing aircraft.

Kellett, after thanking Dorsey for taking time out of his campaign for re-election, called on Dr. George W. Lewis, who had been appointed in

1934 by Secretary Newton D. Baker to the Special Committee on the Army Air Corps, so he was vitally interested and an active participant in planning for the future of military air power. Lewis became the first executive officer of the NACA in 1919 and in 1924 became its Director of Aeronautical Research, a title he retained until 1947, a year before his death. (Lewis Field at the NASA John H. Glenn Research Field in Cleveland, OH is named in his honor) And although he had no questions, Lewis seconded the sentiment that the Dorsey Bill “when carried through, will be the greatest thing that has happened to the rotating wing aircraft. We also have a program we have submitted to the War Department, covering the fundamental research on the problems in rotating wing aircraft,” effectively serving notice that the N.A.C.A. also wanted a piece of the Dorsey-Logan pie.

Kellett then called on Kern Dodge, Philadelphia's director of public safety and a prominent member of the Pennsylvania Aero Club. Dodge had been caught up early in the excitement generated by the Wright brothers, and there was a photograph from 1912 showing him seated in a Wright Flier.¹⁴⁹ He also had authored the REPORT ON REGIONAL AIR TERMINAL FOR THE PHILADELPHIA REGION in 1929. It is not known if he was attending in an official municipal capacity, but there can be no doubt that, given his history of interest and participation in matters aviation, he would not have missed such a historic gathering. But he had nothing other than platitude to add, and his brief and eminently forgettable remark allowed Kellett to end the presentation, not before E. Burke Wilford called for (and received) “a rising vote of thanks” for Dorsey.

Thus Frank G. Dorsey's presentation came to an end – the money allocation process would take much longer than he anticipated, and be greatly reduced, yet it would serve through its allocation to spur the growth of the rotary wing aircraft industry – the helicopter. Gregory would effectively see that no developmental funds would go to the Autogiro, and although it would see relatively ineffective service¹⁵⁰ in foreign military forces (see mainly Russia,¹⁵¹ France,¹⁵² England (Cierva C.30A used in coastal radar calibration and the Hafner Rotachute rotary kite),¹⁵³ Sweden,¹⁵⁴ Japan¹⁵⁵ and Germany (including the Fa 330 rotary kite).¹⁵⁶ But as the lack of military operational success was years away, and the lack of military procurement of the Autogiro immediate but not apparent to those who did not, or refused to

comprehend the profound implication of the modification of the subtitle of the Dorsey Bill from ‘Autogiro’ to ‘Rotary Wing and Other Aircraft’, Kellett felt comfortable (as probably did his audience), on surrendering the podium to A. G. Galloway of the U. S. Department of Agriculture who would speak on “Agricultural Uses.”¹⁵⁷

Galloway's talk reflected an optimism as to the suitability of rotary wing aircraft for agricultural uses. It was a theme that had intrigued since the earliest days of the Autogiro in America and had been reflected early on in the July 1931 *National*



Farm Journal cover showing a Pitcairn PCA-2 at a county fair. Autogiros had already been effectively employed in crop spraying¹⁵⁸ (a role that Kellett Aircraft would attempt to revive during the 1959 – 60 time frame).¹⁵⁹ George Townson, who would shortly speak to the meeting, had successfully done crop spraying in a PCA-2 for Giro Associates of Morristown, NJ, in 1938,¹⁶⁰ and who would provide a demonstration of Autogiro crop dusting at the Philadelphia Airport after the close of the sessions on Saturday.

The proposed agricultural possibilities were not lost on either the audience nor the Chairman, who quickly queried the speaker as to the policy with regard to the crop spraying patents then held by the government, in stating: “I understand that all the development work carried on by the Department of Agriculture for the development of that spraying and dusting equipment has resulted in basic patents, and that it is going to be the policy

of Mr. Galloway's Department to see that they are given over for the free use of the public, of anybody who wants to use them and install them in those machines for crop-dusting and spraying. That is very generous." Galloway immediately confirmed this statement, and after a short question by Gerard Herrick as to the Agriculture Department's desire for more efficient rotary wing aircraft payloads, the session moved to quickly to a familiar presentation by an equally familiar speaker (but who himself was not equally comfortable as he elected to read his presentation, staging "I am not much of a public speaker . . ."), the noted Autogiro pilot John M. "Johnny" Miller who would speak on "Autogiro Piloting Technique".¹⁶¹

Miller¹⁶² was one of the most experienced Autogiro pilots in America and, vis-a-vis his air show performances doing the loop, probably being the most well-known and heralded feature. He had just published a cover story in the September issue of *Popular Mechanics* entitled "The Missing Link in Aviation"¹⁶³ (cover included *supra*) in which he advanced and advocated for greater uses of the Autogiro in inner-city heliport traffic, and would in 1940 publish a detailed essay expanding the same theme as part of the *Aeronautics* booklets titled "Civil Uses of the Autogiro."¹⁶⁴ Miller would also provide a demonstration of his Autogiro flying abilities to the meeting participants with a demonstration after conclusion of the Saturday session at the Philadelphia Airport.

As Miller was both an Autogiro and fixed wing pilot (his email address, established when he was 99 years old,¹⁶⁵ was "Jenny2Jets"), he compared the techniques involved in each kind of flying. It was a highly generalized presentation¹⁶⁶ and would have been familiar to the Autogiro pilots in the audience, but then Miller ventured into what proved for many uncharted territory, landing an Autogiro 'blind' when he stated:

"I am especially interested in the development of blind landing aircraft. I had some airplane experience, and I can see from that, that it is very necessary to develop some different type of aircraft before blind approaches and landings can be made everywhere, or even anywhere near everywhere. Although blind approach systems are being developed very rapidly recently, they will always be confined to certain specific locations, with the present type of aircraft. However, with the development of

the autogiro or any other type of rotary wing aircraft capable of vertical descents, I think that it should be possible to develop a very simple means of landing blind in very restricted areas, and with a very minimum amount of special equipment."

At the conclusion of Miller's presentation, Kellett asked if there were any questions, and then turned immediately to Lieutenant Gregory, also an experienced Autogiro pilot who, given the question he would ask, may even have been trying to get Kellett's attention. Gregory had apparently honed in on the "blind landing of an Autogiro" comment by Miller. Gregory commented: "In general, I agree with Mr. Miller. There are a few points that I would question, Particularly (sic) would I like to know what he has in mind to make an autogiro safe for landing blind." Miller, replied with an experienced pilot's attention to detail:

"Well, I have several ideas on the subject of blind landings with autogiros. My idea consists mainly of slow approaches on instruments to somewhere near the vicinity of the center of a regular flying field, and then a slow descent, with power on, until the wheels contact the ground. With power on, an autogiro can descend very slowly and steeply, and if headed into the wind it makes it that much steeper, and I believe, although I have never been able to prove this yet, that this type of descent could be made just as well on instruments as in contact flying when visual reference is [not] possible. I don't see any reason why a pilot couldn't refer only to instruments, depend entirely on instruments, and allow the ship to settle slowly until it makes contact with the ground."

Gregory, apparently relieved that Miller wasn't proposing anything so innovative that it would divert attention of either the government or engineers attending the meeting, responded: "That is O. K., but it would require more or less the same equipment that we now have for landing blind." Miller, who had obviously thought deeper on the subject (it was, after all, part of his *written* presentation), reacted in disagreement:

"I doubt that very much, because for instance, suppose we take one idea I have

had in mind for several years. – If we had a non-directional radio beacon in the center of an airport, and an ordinary radio compass in the ship, it would be possible to approach the beacon by means of this radio compass from, a down-wind direction, that is, headed up-wind, and slowly approach the beacon, using just enough power to bring the ship up-wind to the center of the field. When the ship is over the beacon, the ordinary radio compass needle would wobble, showing that the ship is over the radio beacon. Then a descent could be made from some altitude such as three hundred or four hundred feet, and the ship couldn't possibly miss any ordinary field under those circumstances.”

And, after giving his explanation, Miller *did agree* with Gregory's follow-on repetition of his earlier assertion that “it does require similar equipment, equipment similar to what we have now for approach for blind landings.” But Gregory then added: “I think you would need more than your radio compass to make a blind landing” and the encounter between the two experienced Autogiro pilots ended.

Chairman Kellett, wishing no doubt to insure that the confrontation remained finished, and perhaps seeking to furnish some resolution, proceeded to call upon other seasoned Autogiro pilots in the audience. First Lou Leavitt, who had earlier changed his name from Levy,¹⁶⁷ refused comment as did Paul Hovgard – as James G. Ray was the next speaker, it was understandable that Kellett did not call upon him. The session did not end, however, without a comment from E. Burke Wilford as to “engine cooling problems at low speed”, a topic that presumably flowed from Miller's comments about low-speed landings (particularly blind landings), but further comment was deferred as engine cooling was a topic for the next day. And it was obvious that Kellett was anxious to get to Jim Ray's presentation on “Commercial Uses of Rotary Wing Aircraft”¹⁶⁸ as it promised to be authoritative vision of the future – but if the Chairman and the audience were expecting a celebration of the Autogiro, the use of the words ‘rotary wing aircraft’ in the title and the content of the presentation signaled a different (and presumably not completely comfortable) direction.

Kellett introduced Ray with high praise and anticipation indeed. He stated: “I think if anyone

can tell us about commercial uses, it is Mr. Ray. He flew the first autogiro built here,^[169] he has flown practically every one that has been built here, and he has experimented with all types of uses for them.” And while “Big Jim” Ray had fully earned such a reputation, any expectation that he would sketch a rosy future for the Autogiro was soon put aside. Ray's detailed presentation, which would later be deliberately mischaracterized by author and Harold Pitcairn admirer Frank Kingston Smith as remarks on “his recent experiences in Europe in an impromptu, complete extemporaneous speech” for reasons discussed *supra*, began with a disclaimer:

“Mr. Chairman – Ladies and Gentlemen: The scope of this paper is not limited by the uses to which rotary wing aircraft have been put in the past. There has been no production of commercial machines for the last five years. But there has been a great amount of technical progress. Craft can be built today that will have a lot better performance than those designed in 1931 or '32. I have attempted, in addition to cataloguing some of the uses that were practical with the older Autogiros, to estimate the uses that can be found for new present day designs embodying the latest improvements in the development.”

And Ray was true to his word – while he cited past commercial uses derived from Autogiro experience, there was little doubt that he intended to reference the latest technological advances with which he was familiar – and it was well known that he had returned from Europe where he gained knowledge of the work of Flettner, Focke and, of greatest importance, Raoul Hafner. Ray referenced the security occasioned by rotary wing flight and additionally stated that: “rotative wings can give the private owner a considerably greater utility. Either the *Autogiro with jump take-off* or the *true helicopter* will permit him to land and take off most anywhere. The addition of roadability, that is; a road drive to permit the machine to run through the streets under its own power and with its blades folded out of the way, will make it possible for the one vehicle to take you from where you are to where you want to go. This complete fulfillment of one's personal transportation requirements can only be attained with rotative wings.” (emphasis added)

The “roadable” Autogiro had been a Pitcairn project for the Bureau of Air Commerce under the leadership of Eugene Vidal, and Ray had previously delivered¹⁷⁰ the Pitcairn AC-35¹⁷¹ to the government by landing it in a Washington, D.C. park, folding its blades back, and driving it through the streets.¹⁷² But it is significant that Ray saw such a PAV (personal aerial vehicle) in terms also of the “true helicopter” – its first mention in his presentation, but not the last.

Ray spoke of the ability of a rotating wing aircraft to shorten travel time and increase convenience in “large metropolitan or built-up areas, such as Greater New York . . . between different parts of the city . . . Rotary wing aircraft can be operated from especially prepared terminals scattered through these areas to give a service that will be several times faster than any other vehicle can give.” Additionally, anticipating the creation of metropolitan heliports (and the projected Fairey Rotodyne service),¹⁷³ Ray talked of central city-to-central city service (citing the aviation success, but pointedly, *not the commercial success*, of the 6-place¹⁷⁴ Pitcairn PA-19 ‘Cabin Autogiro’¹⁷⁵ and acknowledging its noted designer Robert B. C. Noorduyn who was attending the meeting) as well as the “Practical shuttle service with both passengers and mail from city center to the airport.”

With regard to the pending implementation of such airmail feeder service, as Ray felt it was imminent (he was correct, as detailed *supra*, such service would commence the following July but in Philadelphia, not Chicago as Ray speculated), he proceeded to make some comments on rooftop operations – his comments regarding potential operations focused on the difficulties related to both the Philadelphia and Chicago post office roofs and clearly evidence realistic observations and consideration of the attendant aerial engineering problems.

Ray also cited the potential for rotating wing aircraft (his characterization – not specifically the *Autogiro*) for transport to remote mining sites, the use of the Florida Year-Round Club’s use of a four-place cabin Autogiro (note that he had referred to the PA-19 Cabin Autogiro as a 6-place aircraft previously) that “for the last five seasons this machine has been operated from a golf fairway in from of the Biltmore Hotel to take hotel guests and club members to such places as fishing clubs on the Florida Keys or to hunting lodges back in the Everglades – transportation jobs that cannot be done by other means of transport.” (But Ray

revealed that the aircraft had been destroyed in a hanger fire, but it was replaced at a “high cost”).



PA-19 operated by Florida Year Round Club

Jin Ray also spoke of the “possibility of flying on and off of liners at sea” and proceeded to provide what must have been an understandable and amusing example of possible rotary wing aircraft utility to the audience. He related:

“Suppose you are two days out, let us say, on the “Normandie” on your way to Europe, and you receive a radiogram that your oldest son has had a sudden attack of ‘blonditis’. Now all you do is to go on to Europe and catch the next boat back which will be a matter of ten days or two weeks before you can get home. If you could be flown over to the deck of the inbound “Queen Mary” which happens to be nearby, you stand a chance of getting home for the wedding. By the way, the deck on the front of the “Normandie” is suitable for use as a flying dock now without further changes.”

Ray also touted the rotary wing aircraft as an ideal stable camera platform for aerial photography, citing the photographic success achieved by shooting the “Morro Castle” ship disaster off the coast of New Jersey from an Autogiro. This led Ray into commenting on Coast Guard rescue work, for which he directly stated “[s]traight helicopters would, of course, will be the most suitable because they will not require a wind to hang motionless and remain (sic) airborne while someone or something is taken aboard of landed.” He then went on to add: “Even a life-guard at the beach could use a helicopter in his work. While the pilot hovers a few feet above the water the guard can go down a

special apparatus similar to a rope ladder, get hold of the drowning person, fasten him to the apparatus and then the pilot by rising a few feet lifts everything above water and goes to the first –aid station. Why not?”

Ray then concluded his session with an enlarged description of the uses of rotary wing aircraft should a “hurricane strike New England [as had previously occurred]” where “all means of communication knocked out by the storm, it was impossible for the outside world to find out the extent of the damage. It was over a week before it was known how many people were actually killed. Why shouldn’t we be able to fly in and get such information.”

Ray’s focus on rotary wing aircraft was completely in keeping with the theme of the conference, but must have proven disconcerting to those who saw him as a champion of the Autogiro. Kellett, reassuming the podium and usually quick to command the post-presentation comments by direct questions, was seemingly as a loss for words, commenting only that Ray’s presentation “ought to intrigue our imagination” and letting an unnamed questioner ask what must have appeared an incredibly naïve and unsophisticated, and perhaps even inappropriate question about what happened “[i]f a pilot takes his hand off the controls, does he come straight down?” Kellett didn’t even allow Ray, to whom the question had been directed, to answer, but stated: “No, in ordinary weather conditions, he could fly hands off for a certain length of time.” This answer was not apparently in the detail sought by the questioner, who asked again: “If he takes his hand off the controls, what happens?” Kellett again quickly answered, and by now it is apparent that: 1) Ray would not be allowed to speak any more; and 2) the topic would remain deflected from Ray’s optimistic view of the helicopter to a fairly trivial flight control comment which bore no relationship to the presentation topic save for the fact that Ray was *superbly* experienced to give an authoritative answer, presumably why the question was asked of him in the first place.

It may even have been that Kellett was genuinely relieved to have prematurely ended the Ray presentation with no discussion, and therefore not to have face questions stemming from his advocacy of the “true helicopter” as the thread of the discussion was superficially taken up by Kellett himself, a member, Lieutenant H. Franklin Gregory stating “I don’t think it would settle in any case, it

would fly” and John M. Miller’s unacknowledged offer of “I think I might be able to clear some of that up.” Thus Jim Ray’s session ended – and there can be little doubt that those who advocated a rotary wing aircraft future based on the Autogiro were disappointed – Ray had managed to place the helicopter front-and-center, and it was about to assume even a more preeminent position in what was to prove an unanticipated, startling, and ultimately pivotal presentation by Raoul Hafner. And if Ray’s presentation began to turn the conference, that redirection would be completed by Hafner – a true turning point for the helicopter as rotary wing aircraft future vision.

Kellett, appreciating that Hafner (an Austrian then resident in England) had come from England “especially for this meeting”, and that “he has accomplished a most interesting development there” urged the audience to extend to him a very hearty welcome” which elicited a round of applause. As Kellett personally noted, with regard to Hafner’s new developments “I have seen it over there, and we have followed it with a great deal of interest, and it has great possibilities”, it would seem that this was an anticipated presentation devoid of surprises, as the previous Ray presentation had produced – but that was to prove an unfounded assumption, for Hafner did have surprises, and he would set the stage in the first part of his presentation, but then spring forth in the second part.

Hafner¹⁷⁶ began his paper “The Hafner Gyroplane”¹⁷⁷ by factually lulling the audience with a claim of the familiar – “The subject of the paper is substantially identical with what I said a year ago before the Royal Aeronautical Society¹⁷⁸ and later at Cambridge University, it is my research work in respect of rotating wing aircraft, together with material connected with it which I thought would be of general interest.” As Hafner’s paper had been widely read in America, the territory would have been familiar – and perhaps many might also have seen the slides of his various rotary wing aircraft he illustrated his talk with, and his comparison with conventional gyroplanes would not have been such a leap as to discomfort those of the Kellett and Pitcairn companies present. But while those in the audience may have perceived as being *evolutionary*, what Hafner was illustrating was *truly revolutionary* – the “spider rotor hub design” and torsionally flexible tie rods that:

“[W]as the first to successfully integrate the ideas of cyclic pitch control with blade flapping and lagging degrees of freedom . . . that “provided a means of increasing collective pitch of the blades and also tilting the rotor disk using cyclic variations of blade pitch, but without tilting the rotor shaft with a control stick as was used in Cierva’s “direct control” system. . . innovation in Hafner’s rotor design was in the use of torsionally flexible tie rods connecting the blades to the hub . . . really the first step toward the development of a bearingless rotor hub concept, where bearings and hinges are replaced by flexible elements.”¹⁷⁹

Hafner passed over his revolutionary innovations in less than two pages of his presentation, slipping effortlessly into a discussion of aerofoil section selection and joystick arrangement – showing images of his A.R.III fitted with a conventional rudder that looked from the audience as a variant of the conventional gyroplane, *but it actually was different* and that difference was hinted at during his discussion of the gyroplane’s direct take-off, what Hafner called “an energy-assisted take-off.” He contrasted a traditional Autogiro “jump take-off” with the A.R. III’s “towering take-off” “which has been pleasantly described as the “gentle but firm act of levitation which commences each flight.” Hafner analyzed that:

“The jump type of start involves an inefficient conversion of energy due to high induced airflow velocities, and is generally, particularly if there is no wind, followed by a substantial loss of height to regain speed after reaching the top of the leap. The purpose of the towering take-off is primarily to hold the machine after the start in the proximity of the ground, thereby keeping the induced drag down, while the air-screw accelerates it to climbing speed, and to regulate the rate of conversion of energy in the rotor through the sensitive feel of this control, in order to suit varying wind conditions.”

And then, to the delight of the engineers present, Hafner proceeded to provide a “brief summary of results from my theoretical work.” He concluded the first part of his presentation with what would

prove a transitional prophecy: “The gyroplane of today can perform these duties satisfactorily, and the helicopter, *the logical development from it*, will not only improve on it, but will be able to challenge the fixed wing plane in almost any department of flight. In its new form, as I visualize it, and which may well appear in the near future, it will be a craft of mechanical simplicity and aerodynamic beauty and performance calculations give indeed justification for great expectations. I will speak of this tomorrow.” (emphasis added)

And thus Hafner’s first presentation ended – it had proceeded quietly and eloquently, some might have even described it as elegantly, from the known and comfortable to the unknown that Hafner had seen – it was the transition from the Autogiro past to the helicopter future and the future helicopter.¹⁸⁰

Given that the audience had been placed on notice that the best was come on the following day, it is not surprising that when Chairman Wilford opened the floor to questions, Hafner received only a cursory inquiry from a certain Mr. G. E. Backrath as to the horsepower and top speed of the Hafner A.R. III Gyroplane, a query that elicited a brief technically-oriented reply. But then came a genuine moment of public recognition bordering on accolade from one of the few in the audience with enough depth in engineering combined with rotary wing aircraft research to recognize the significance of what had just been presented, and what it portended. Professor Montgomery Knight stated:

“Mr. Chairman, if there is time for a few simple observations, I would like to say that Mr. Hafner’s paper marks a very significant spot in the development of this type of aircraft in England. It could mark such a spot in this country if we could realize the full significance of what he has done. In short, as I see it, he has combined the much maligned mathematics with careful experimentation and an ability and ingenuity in design that I think is rarely equaled. This combination is practically unbeatable. But all three of them, all three ingredients, are essential if a development of this type is to be carried on to a successful fruition. And when I say that I think this marks a very important spot, not only in English development, the development of the helicopter or the autogiro, both in England, I think it should and could

mark such a spot also in this country, if we will only realize the importance of that combination of ingredients.”

Knight’s comments were also an indirect critique of American rotary wing development that, in terms of the Autogiro efforts of Pitcairn and Kellett, had ignored, or at least seemingly taken little notice of the work and direction of Hafner, and a rather lame reply was ventured by Pitcairn engineer Agnew E. Larsen who was supervising in the jump take-off PA-36 project, even then falling behind and exceeding budget. Larsen replied:

“I think after the speeches today, there is little more to be added, other than this. I have observed Mr. Hafner’s work in England, and read his paper before the Royal Society, and can say with very strong conviction that in this whole line of development, I think he had done a most magnificent job of combining three phases, -- the mathematics, the mechanical design and the practical application, and there are few papers I have ever read that I have derived the enjoyment out of that I did from the paper he read before the Royal Society. Those of us here this evening, I think are quite fortunate in having a repetition of that same experience. I feel Mr. Hafner deserves not only the congratulations of this body, but of all aircraft men, for the path he had carved out for himself and the rest of us.”

And while Larsen was correct in characterizing, and thereby minimizing, Hafner’s content as a “repetition of that same experience” and a particularly personal “path he has carved out for himself”, he evidenced absolutely no ability to recognize that Hafner had irrevocably redirected the focus to the helicopter. The recognition would wait until his second presentation the following day, but it was coming.

And with that the meeting adjourned to a banquet at the Penn Athletic Club, with noted Toastmaster Casey Jones and a speech/paper presentation by Edward J. Nobe, then Chairman of the Civil Aeronautics Authority. Although referenced as a paper, it lacked a title and was more an after-dinner speech of the kind afforded attending dignitaries who have little direct to contribute. So aside from comparing the assembled rotary wing

aircraft industry leaders to “the cult of dry fly fisherman in patience, in cunning, in willingness to sacrifice immediate reward for the game”, a suspect analogy at best that would probably only work, if at all, after a good meal and strong drink, Nobe had little to contribute . . . but he tried, not without some success.

He established his slim bona fides with the claim that the CAA owned two seven-year old Autogiros “[b]ut we still own them. And we still use them. In my modest way, I not only had faith in the autogiro seven years, but I continue to have faith. Nor am I one of those who believe in justification by faith alone. Our autogiros work.” And this surely sounded good to the Pitcairn and Kellett personnel at the table. He placed the rotary wing aircraft industry in the growing importance of aviation (citing C. R. Smith of American Airlines), and invoked with evangelical fervor: “The new era of aviation is not coming – IT IS HERE.” He also pointed to the application of the CAA for \$400,000 in Dorsey-Logan funds “in order to help you.” It was what the audience wanted to hear, and he delivered. Thus the evening ended and the stage was set for the Third Session the following day.

The Third Session – Saturday, October 29, 1938 9:30 to 10:30 A.M.

This session, titled “Research Programs” and led by Dr. George W. Lewis, began with an observation familiar to all who chair the first session after the conference banquet. E. Burke Wilford, in introducing the session chairperson, commented that “[i]t appears that “men with rotors and wings” did a little high flying last night and some of the boys are a little late.” Burke continued: “Dr. George W. Lewis needs no introduction to us, because the fellows that are here this early, are actively working in this field. He knows them all, and here is the doctor’s chance to get back at us for all the wild suggestions we have made to him.” Taking the podium, Lewis launched directly into the session, not unmindful that he was speaking to “a small group of the faithful” but feeling that “it is well to start on time, because it is a long morning program and some of the people are thinking about going to [the] Penn-Navy football game.”

Dr. Lewis, of the N.A.C.A., made some introductory remarks for the session asserting the value and priority of rotary wing research programs, ¹⁸¹ stating that:

“This morning we are here to consider the subject of programs of fundamental research in the problems of rotating-wing aircraft. . . . I wish first to emphasize the extreme importance of a soundly conceived and carefully planned investigation as the basis for a successful attack on any engineering problem. Although progress at times has resulted from a single outstanding discovery the progress in these cases has usually been of a more or less revolutionary nature. Once the revolution has taken place the success of subsequent developments is almost universally dependent upon intelligently planned and carefully coordinated study of the problems involved in the application of the original revolutionary idea. I believe we may say that rotating-wing aircraft have definitely passed the revolutionary stage and their future development now depends on a rational and orderly series of step by step solutions of the detailed problems involved in their successful design. There remains a large field for fundamental research in the detailed mechanism of operation of the rotating-wing types. Thus the research programs we are to consider this morning are of paramount importance not only to the rate at which we may expect progress to be made in the development of rotating wing aircraft but to the probably sum total of the progress to be achieved.”

Lewis was, of course, also making a *simultaneous* argument for an anticipated allocation of Dorsey-Logan funds (which were, at the time of the meetings, still \$2,000,000), arguments directly or indirectly also advanced by the other advocates of rotary wing aircraft research Alexander Klemin and Everett B. Schaefer¹⁸² (with Schaefer presenting) on behalf of the Daniel Guggenheim School of Aeronautics at New York University, Montgomery Knight¹⁸³ on behalf of the Georgia School of Technology (whose paper had been released by the Director, State Engineering Experiment Station of Georgia and hence came with official approval), and R. A. Bailey¹⁸⁴ of the N.A.C.A. (but as will later be seen, this was actually F. W. Bailey, Jr.). And the N.A.C.A. certainly wanted to advance its fundamental research – but then again, so did every institution presenting that day, and each would make their case.

Each of the speakers presented summaries of the rotary wing flight research offerings of their individual institutions along with descriptions of the facilities and extant research programs in terms that were both descriptive *and* persuasive. And as that was clearly the goal of each of the speakers, George W. Lewis authoritatively concluded that “[o]wing to the shortness of the time available, it seems doubtful that we shall have time for discussion. I regret this necessity, as I believe that constructive discussion of research programs in their early stages offers an important possibility of accelerating the progress to be made by the research.”

The first paper was presented by Klemin’s co-author, Everett B. Schaefer. His avowed purpose was to: “first, enumerate some pressing research problems in relation to rotary wing aircraft; second to place on the record some practical methods of wind tunnel technique, developed over the last few years and likewise relating to rotary aircraft.” The subtopics of his presentation clearly delineated the pedigree of NYU’s past and current rotary-wing research, but also sought to extend such efforts into the developing helicopter: Autogiro and Gyroplane Rotor Research; Autogiro, Fuselage and Tail Surface Interaction; Dynamics and Structure; Jump -Off Giro; Helicopter Airscrews (asserting the need for research on rigid blades, flapping blades, freely feathering blades and mechanically feathering blades); Helicopter Stability and Control; Wind Tunnel Set-Up of Model Rotors; and Reduction of Scale Effect in Rotor Testing. All-in-all, a brief but comprehensive and authoritative presentation what was then a major center of such research presided over by the admitted dean of rotary-wing research, Alexander Klemin.

Lewis then introduced “professor Montgomery Knight, formerly the man in charge of one of our wind tunnels, and now in charge of the school at George Tech” and Knight proceeded to describe the GT program in a talk that, as was observed above, had been released by the Director, State Engineering Experiment Station of Georgia. He indicated that his program was interested in, or currently researching, Ground Effect, Level Flight, General Motion, Rotor Stall, Scale Effect, the determination of Performance Calculations, Blade Articulation, Rotor Drive, Stability and Controllability; and Vibration. Knight then proceeded to describe the research facilities at Georgia, including the details of its two wind tunnels, vibration setup, blower laboratory, and announced that the “work of

designing another and very important piece of equipment had been stated . . . a full scale single-seater helicopter which will be used not only to determine the feasibility of the jet drive but also to check the scale effect corrections. Knight then, with reference to slides, took the audience on virtual tour of GT, an impressive, impactful talk that showed Georgia to be a worthy rival in the field of rotary wing research, especially with the ambitions model helicopter project. Perhaps for that reason Lewis felt the need, or at least, seized the opportunity to diminish Georgia's program while seemingly praising it, in stating (emphasis added):

"I have followed for a number of years, the work that Professor Knight has been doing at Georgia Tech, with a great deal of interest, and I certainly do admire his courage in getting into new fields and undertaking very difficult problems. Offhand, I could think of nothing more difficult at the present time than building a helicopter and build an air compressor to drive the blades by jet propulsion. Any one of the problems of building the compressor alone is a real problem. Jet propulsion is a real problem, and *of course the helicopter is a real problem*. I also wish to compliment Mr. Knight on his paper. I wish that more authors would write papers following this scheme of putting headings before the paragraphs. It is a very good paper."

Lewis then introduced "Mr. R. A. Bailey of the staff of the N.A.C.A., at Langley Field [the paper included in the Proceedings, however, was attributed to F. J. Bailey, Jr., Junior Aeronautical Engineer, National Advisory Committee for Aeronautics" which is seemingly correct as several research papers by the latter are noted in Johnson's later volume on *Helicopter Theory*.)¹⁸⁵ It is perhaps not so surprising that the N.A.C.A would send such a junior engineer to perform such a public and important task, as Knight was the session chairperson, but it was an important occasion. As observed by Roger Connor in 2006:¹⁸⁶

"[B]y 1931, the NACA had begun to study the autogiro extensively, but the innovations that occurred in the technology, such as direct control and jump takeoff, happened at the hands of industry, not government researchers, who instead concen-

trated on developing an understanding of fundamental principles of rotary-wing flight. [Ref. 14¹⁸⁷] However, the NACA did succeed in establishing a significant body of knowledge on rotor design that the Industry would not have been able to compile itself. The publications that resulted from this effort meant that the helicopter pioneers of the 1940s did not have to retrace their steps in the field of rotor design and could concentrate on the fundamental issues of control and stability."

Bailey detailed the N.A.C.A. fundamental research and the Technical Notes published by his organization, presumably well-known to the meeting participants. It was clear from the emphasis of his presentation, however, that the N.A.C.A had, and proposed to continue *fundamental* research.

At the end of Bailey's presentation, the final research paper, Chairman Lewis recognized and called upon Dr. Henry Butler Allen, Secretary and Director of the Franklin Institute. Allen, ever the artful director and institution advocate, welcomed the visitors and although stating that he "wouldn't think of taking up but a minute of your time", proceeded to cite "the activities that we have been carrying on for a hundred years in awarding medals for inventions, and your industry stands out in the front rank of those who have received awards."

Lewis acknowledged the Franklin Institute, and Dr. Allen particularly "for the many courtesies that have been extended" and then pressed ahead with a discussion designed to segue to the next session dealing with the future of rotating wing aircraft, and in the process imposed *his* vision of research programs. Lewis stated: [P]ersonally I feel that the greatest advance we can make immediately, and that within the next few years, is in the blade design, including the blade, the aerodynamic characteristics of the blade itself, and particularly the hub mechanism." Adding that "[t]here are many men here who have specialized on this problem, and I would appreciate if it they would get up and just say a few words of what they think are the most important factors in this study." He then proceeded to call upon a select few in the audience, starting with Paul E. Hovgard, who responded: "I am caught unawares. I have a paper to deliver pretty soon, and I have been thinking of that, most of the time. Unfortunately, we have been busy at the Curtiss Company on bids, and I have spent

more time on bids than I have on rotating wing aircraft.” But then Hovgard went on to add:

“Dr. Lewis just now mentioned the importance of the blade design, and the hub mechanism. I want to just stress that point, particularly the design of the individual blades, and while I am on my feet, I think I will just dig out a part of my paper that I was going to discuss, because it was on blade design, and bring out one point that expands in some measure, a point brought yesterday by Mr. Platt. He pointed out that the articulated blade was inherently stable, whereas the rigid blade was not. I think there are articulated blades which are quite unstable.”

And in his slightly extended remarks, Hovgard singled out the *sui generis* aspect of Knight’s presentation on Georgia Tech’s research program – the creation of a full scale helicopter, clearly indicating that he understood the tension inherent in the research presentations between the emphasis of Georgia Tech and New York University (helicopter research vs. Autogiro research, the past and a decidedly different vision of the future). He added: “I am glad to see Dr. Lewis recognizes the importance of blade design, and that there is room for a great deal of work on it. Mr. Knight has done one thing out of the ordinary, in that he is the head of a research organization that is going to build a helicopter of very advanced design, and it is a very daring move, and I wish him all kinds of success.” But then Hovgard seemingly ‘cast his lot’ with Lewis and Klemin, in cautioning the audience that: “It is my contention, however, and Dr. Lewis brought it out in the introduction, that the evolution of the final helicopter or rotary wing aircraft is going to be step by step. First, we will have the very simplest case, that of the autogiro. Then we will jump the autogiro off, and then you will put power in to it. Each step involves new complications, and taking about six steps at once is a very daring move.” And given the number in the audience involved with the Autogiro, it is not surprising that this evolutionary view of rotary wing aircraft research received applause. But as we shall see, at least one participant was probably not applauding – and Raoul Hafner would shortly startle the audience with *his* vision – but that was still a session away.

Lewis, after thanking Hovgard for what must have been a satisfying declaration, turned to

Haviland H. Platt, who was then concentrating on *helicopter* design, and who predictably addressed hub design. He replied: “Well, I don’t know that I can say very much, on hub design, but I will say that I think the most important in hub design for the helicopter is to get all the works into it.” And then Platt, a respected engineer particularly in light of his paper the day before, pandered to Lewis and the N.A.C.A., in stating:

“I do want to say one more thing on this subject of stability, and that is what I had to say yesterday on that subject was on a different phase entirely from the one Mr. Hovgard has touched now. That is, I simplified my problem then by simply considering the static condition, that is, it was positional stability altogether. Now Mr. Hovgard has moved the things forward, and of course that brings in a lot of other complications. In the positional stability, in static operation only, I don’t think the blade design in itself has much to do with it. It is a matter of articulation alone. Of course, when you start moving it forward, this blade design problem becomes very, very important, and I hope Dr. Lewis will get us a lot of information on that problem out at Langley Field. I knew he will.”

Probably feeling a great deal of satisfaction, Lewis then called upon Kellett Autogiro’s Richard H. Prewitt, who could be counted on to speak affirmatively on any program of research that contributed to Autogiro design, which he did, but in a more conciliatory manner (and with the longest sentence found in the Proceedings). Prewitt replied:

“I was sitting here, listening to the programs of these research organizations, and I was very much elated to find that they are so constructive, because after all, we are the people who have to take that information and use it and actually try it in a practical way, and that is the thing that impressed me most in these programs, as outlined, was their possibility for application and for the improvement of design, or actually being able to use your slide rule and some figures that you might, instead of guessing, you can kind of estimate what you are doing to have when you get

through. And that is a very important thing in the design of any type.”

And finally Lewis called upon Pitcairn engineer Agnew E. Larsen, stating: “Mr. Larsen, won’t you come down and say a few words? You know, we who are not from Philadelphia are very proud of this Philadelphia group, -- when you think that all the of the initiative and instruction is right here in Philadelphia, -- Larsen, Prewitt, Hovgard, McClarren, Burke Wilford and others. I am sorry that Mr. Pitcairn can not be here this morning. Is he still ill?” After replying that Pitcairn remained ill, Larsen spoke in a manner predictable for an American Autogiro pioneer advocating the advancement of the Autogiro – he affirmed the Lewis step-by-step approach:

“Dr. Lewis and members present – With reference to the recent program and its use, I think we can honestly survey the time which has elapsed from that period when we were first making autogiros, and groping around for a few fundamentals to learn how to put wings on the fuselage in the right place, and put blades on the hub in the right place, and come up to the present time, facing the kind of intricate problems we have found, and notice the marked difference in conditions to work with. It is a fact that a very useful growing library of real scientific data is coming out of the National Advisory Committee, and the attitude we display is that we will not proceed on any fundamental problem without taking up the library of data which N.A.C.A. have prepared. Mr. Stanley, who is the chief technician in our organization, works continuously with the literature that has come out of N.A.C.A. I think there may be a tendency to ask for pure research, and of course we must have a continuous flow of that, but it is a fact that a lot of research which comes out of the N.A.C.A. is, besides being pure research, applied research and I don’t think we have come anywhere near the time where we can give up our appeal for applied research. I think every phase of the rotary wing art is in a stage where the more N.A.C.A. will do in taking one small problem and ferreting it out in reports for ap-

plied research, the better progress we will continue to make.”

And then Larsen continued, speaking from his own experience at the Autogiro Company of America, in a cautionary, almost admonishing, mode that clearly reflected the superiority which infused in the Pitcairn organization that saw itself as the leader of the American Autogiro community, a dubious (and perhaps dangerous) belief in 1938:

“Just in passing, I have noticed the comments about rigid blades versus flexible blades, and Burke’s reminding you that you never can build rigid blades. I hope you fellows who are interested in feathering and that type of rotor won’t be lured into any ideas of strictly rigid blades. I think you are just going for a terrible fall if you do. You might just as well take flexibility, with all the virtues it can give you, and learn how to apply it. I think that any thought of strictly rigid blades just because you want to feather them, is a fallacy.”

And with Larsen’s statement, to which Lewis agreed, the engineering session came to an end, and, with the N.A.C.A.’s Lewis no doubt feeling vindicated, the podium was passed to E. Burke Wilford for the next session, which would not prove as satisfying, for Raoul Hafner was about to surprise those attending.

The Fourth Session – Saturday, October 29, 1938 1:30 to 1:00 P.M.

The fourth session was titled “Future Types and Development” and it commenced with Raoul Hafner, whose presentation was entitled “The Hafner Gyroplane and Helicopter”¹⁸⁸ and denoted “a continuation of Mr. Hafner’s paper presented at the afternoon session, Friday, October 28th) and as such, was sailing under false colors. But the title served notice that while the previous afternoon’s paper was essentially the same as the Royal Aeronautical paper that was familiar to many in the audience, *this* presentation would also deal with the Hafner *helicopter*.

Hafner began with a declaration that while the previous paper had dealt with the Hafner Gyroplane, this presentation would “an outline of the most recent work, which is leading to the future” *which was the helicopter* -- and he left no doubt

from where he had come and, of greater importance, what he envisioned the future of rotary wing aircraft to be. Hafner did not hesitate in declaring in a manner that could not have reassured the assembled Autogiro/gyroplane devotees, and in fact must have been perceived as a bombshell (emphasis added):

“In spite of the fact that the success I have so far achieved is connected in popular report with a gyroplane which embodies my principles of rotor construction and control, the investigations and experiments in respect of rotative wing aircraft, which I have carried out almost single handed over a period of nearly ten years, have always had as a one of their ultimate aims the practical helicopter, which, *I believe, I can now claim to have achieved with a single rotor design.* The single rotor helicopter represents an aerodynamic ideal, which has its analogous counterpart only in the sailplane, and the degree of its mechanical simplicity and consequent reliability closely approaches an extreme. *At this date very little remains to be done before an experimental construction might be hopefully undertaken.*”

Hafner went on to explain that :

“[M]y reasons for constructing this gyroplane, after having built two experimental helicopters,^[189] was partially because with limited funds and for considerations of policy I was forced to produce a rounded and practical result, which I was not then in a position to achieve in the form of a helicopter, and partly because I decided to approach the final goal by stages, the first of which represented the solution of the rotor control and its testing in practical flight, which could be best achieved in the manner just mentioned. On the other hand, I was fully aware that my methods of rotor control and construction in themselves represent an important asset to the gyroplane; so much so that independent development in this direction is definitely desirable.”

Hafner thusly, in a single instance, threw down the gauntlet – he *had* achieved his rotor control system

by incremental effort – his unique ‘spider rotor hub’ “gave the autogiro a new level of performance and ease of piloting control.”¹⁹⁰ And now this gyroplane innovator, taken seriously by this Autogiro community, was announcing that his developments were now to be applied to the helicopter!¹⁹¹

Hafner proceeded to describe briefly his proposed gyroplane evolution, the A.R.4, “a two-seat gyroplane” which is a “compact design with pleasing modern lines and comfortable accommodation” and which “will be easy to take-off, to manoeuvre in the air and to land, and owing to its variable pitch rotor, together with the rudder and tail wheel control, perfectly safe to handle on the ground even for an unexperienced pilot, however strong the wind.” And as this generally, as a concept, would have been familiar to the audience, it would likely have evoked nods from the listeners, but if they thought that Hafner would continue in this manner, they were immediately surprised as he returned to the helicopter with an insightful commentary on the Focke machine, and in the process revealed that he had carefully studied and considered the most advanced European designs, something which few in the audience could claim.

Hafner *confidently* continued (emphasis added):

“I now come to discuss the development of the helicopter which also depends on these basic methods of rotor construction and control. If I did not believe that a genuine solution was thus provided for gyroplanes I should not have had such a self defined basis for my most recent work on the single rotor helicopter which seems to be the outstanding possibility in the rotative wing field. *I have very carefully considered all helicopter projects known to me*, of which there are many untried and available to experimenters, but there are only few with just claims to efficiency and usefulness.

I would refer first to the type embodying two superimposed co-axial rotors which has shown a measure of success. The outstanding difficulty here appears to be the formidable mechanical complexity of the rotor control and drive, which severely prejudices the safety of this layout. In addition to that it is necessary to provide a substantial gap between the upper and lower rotor in view of the flapping freedom

of their blades. This means that except perhaps in hovering or truly vertical flight, the most important portions of the blades are subject to most undesirable cyclic fluctuations in angle of attack, owing to the fact that in forward flight the rotors do not lie concentric in the slipstream. If we, for instance have two rotors, and the machine is flying forward, you can see that the slipstream of the upper rotor meets the lower rotor, not concentric, and that the portion of the blade, which is the most important portion, because of lift efficiency coming from it, not the middle portion, -- always during one revolution enters the slipstream once, and of course, there being such a varying air flow, its effective angle of incidence is impaired, and the handicapping is very great. I consider this a very serious handicap for this type of rotor as to efficiency. Further, there is the disadvantage of the constructional expense of two rotors with the effective disc area of only one."

And then Hafner proceeded to evaluate the Focke twin-rotor configuration, the helicopter that was even then so exciting the American military with reports of its success. He stated:

"The most successful helicopter so far is the Focke. However, the side by side arrangement of rotors had little technical appeal to me, largely owing to the structural and mechanical mass, complexity and drag necessarily involved. A more serious disadvantage lies further in the possibility of a minor defect in one rotor, which in a single rotor machine would necessitate at most a heavy forced landing, as is already known from gyroplane experience, but may well in this type destroy the lateral balance beyond the range of control and end in disaster.^[192] May I recall that multiplication of rotors, contrary to power units, is associated with a reduction in reliability. I feel strongly that Professor Focke has followed a false trail and that evolution proceeds in another direction towards simplicity and refinement. This is in no way intended to belittle his achievement in solving the problem he set himself, with all its (sic) attendant complications, labor and

research, which I fully appreciate. In short, neither of the above constructions is, as I see it, the solution of the helicopter; indeed I would go so far as to say that if I thought that this age-old dream were to have such a cumbersome ultimate fulfillment, I would confine my activities to improving the gyroplane.

However, I consider that the value and importance of the helicopter lies in its inherent potential simplicity as it offers an aerodynamic ideal. It has the qualities to challenge the fixed wing aircraft of medium size, in almost any department of flight, except perhaps, maximum speed.

With this in mind I developed my project of single rotor helicopter, which is covered in various patent applications. It may seem somewhat daring at first inspection, but closer study reveals its sound technical basis. It consists essentially of a single low-torque high-speed rotor controlled similarly to that of the A.R.3 Gyroplane, and a suspended fuselage adapted to receive aerodynamically the requisite balancing torque from the rotor down-wash. Its appearance may be strange to eyes used to aeroplane lines, but the fact remains that it represents structurally and mechanically a logical combination of practical features, and my confidence in its aeronautical authorities."

Hafner then went on to define what he meant when referring to a "low-torque rotor", complete with torque calculations and showing how his derivation came from the A.R. 3 Gyroplane endeavors. (Appendix II of the meetings Proceedings reprinted Hafner's paper "An Investigation into the Problem of Rotor Torque of a Helicopter"¹⁹³ as he had referred to several times during his talk, and it was apparently little known to the meeting participants). Hafner went on to claim that with regard to his helicopter design "[t]here is only one aspect of the machine which has involved original work, that is to say the correction of the rotor torque by the fuselage shape. The torque involved and the nature of the induced airflow can be predicted with reasonable accuracy, specially for the stationary hovering case, which is the critical one." The fuselage, to which he was referring, was "a nacelle in the middle, changes regularly and assumes the shape of a profile, a rather thin profile, about 20%

thickness fore and aft of the nacelle.” He was referring to:

“[T]wo helicopter designs in preparation, the P.D.7 is an advanced one, and the smaller one, the P.D. 6, is only an experimental machine. The experimental machine is powered with a Propcher engine, and is a single-seater about the same size as the existing A.R. 3 Gyroplane, and I expect to get 150 miles an hour top speed with it, and about 1500 feet rate of climb, whereas the P.S. 7 machine will be a development from it, and we calculate the maximum speed at 210 miles per hour, which is the maximum permissible speed, because at that speed the advancing tip is already coming very dangerously near the speed of sound. It is other considerations that limit the speed, not the power itself. The maximum rate of climb of this machine, near the ground, will be 3800 feet per minute.”

And with that Hafner’s presentation came to an end – given his reputation and the nature of the assembled meeting participants, he had just “pushed the envelope” and projected rotary wing developments that bordered on the fantastic in 1938. His technology was sound¹⁹⁴ and designs so modern that they evoke admiration even today.¹⁹⁵

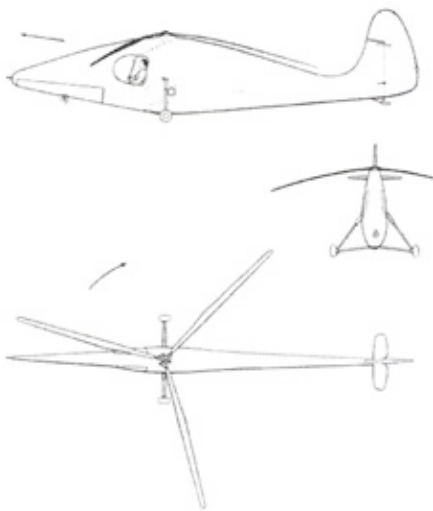

Figure 9: Raoul Hafner's PD.6 relatively advanced looking helicopter concept of 1939, although it was never built. (Westland Helicopters.)

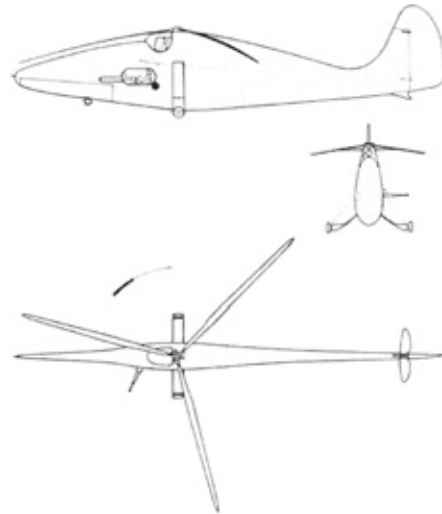

Figure 10: Raoul Hafner's larger PD.7 helicopter concept of 1939, although it too never left the drawing board.

Wilford allowed five minutes for discussion of Hafner’s presentation, and immediately received a question from Mr. Brye dealing with a comment Hafner had made the previous day, an engineering question of little consequence that was quickly dealt with. But then Wilford called by name a “Mr. Gerhart, of Wane University, who, I believe, is the only professor that teaches helicopters in America, or has a regular course.” But if Wilford expected some sort of learned rebuke from the hallowed halls of academe, that was not how it worked out.

Gerhart provided a unique affirmation of the revolutionary nature of what the audience had just heard, and stated: “Personally, I think that it is worthwhile coming quite a distance to hear these papers. If this were a religious meeting, I would say we are at a revival, in view of the very (sic) inspiring talks that are going on, in particular Mr. Hafner’s . . . I was very much interested that Mr. Hafner was able immediately answer the [engineering] question just put, because that has come up a number of times, whether you could balance with either a single surface or a single screw.” Gerhart then went off with comments regarding composite aircraft, causing Wilford to cut off further discussion with “[t]he professor has used up the five minutes. We will be talking all afternoon about the surprise Mr. Hafner has given us.” And so he turned the podium over to Paul Hovgard, who had spoken previously, confident that it would be a more conventional vision of future rotary wing aircraft.

Wilford identified Hovgard as “a research worker for the Curtiss Company” which was consistent with the brief description Hovgard had given *en passant* in his previous extemporaneous remarks. Hovgard’s presentation, entitled “Future Types of Gyroplane”¹⁹⁶ itself signaled a return to the familiar, and he did not disappoint.

Hovgard, formerly a Grumman test pilot, who on April 25, 1933, had flown the XJF-1 (Grumman J2F-6 Duck) prototype, began his presentation with a disclaimer that clearly revealed that he was intimately aware of the constraints and hidden and not-so-hidden motives of previous speakers, stating that:

“My position is quite unique among he speakers of the aggregation, because I am the only one who is not engaged either in the construction of rotary wing aircraft, or in a research or consulting capacity, or who is not trying to promote some type of rotary wing aircraft. For that reason, I have more freedom to say what I think than the others, because I am not obligated to any certain design of any type, and the only curb I have on what I say is that there will be more freedom in criticizing what I have to say, because you all know my status.”

Hovgard, who, given the range and currency of his knowledge of rotary wing aircraft, was clearly being disarming, began his substantive presentation with the statement that “[e]xperimenters have been working on helicopters for a very long time . . . “ and continued that “[p]rogress has already been made along some lines in the rotary wing field. The type with aerodynamically driven articulated blades and with hinged controls, had been used commercially,” obviously referencing the early Cierva and Pitcairn Autogiros; and then he acknowledged that “the War Department of this country is now trying out another type in which the rotor is tilted for longitudinal and lateral control and the wings, ailerons, and elevators are not used,” the direct-control models then either in service in Europe (Cierva C.30A)¹⁹⁷ or under development in the United States (Pitcairn PA-22 and PA-36; Kellett KD-1).

From the perspective of a non-rotary wing aircraft participant, Hovgard saw the issue of future aircraft as:

“The first question to confront the engineer is, should he fall behind the leader and try to catch up, or should he consider all possibilities and choose his course. The leaders in production now are those building Cierva Autogiros. They have attained some degree of success and are working on further improvements of existing models, and on the creation of more advanced designs. Other type have been produced experimentally, and, whether the engineer chooses to follow the leader or strike out for himself, it is well to study existing and proposed types to the fullest extent possible before choosing any course.”

And that is what he proceed to do.

Beginning with a definition, Hovgard expansively advanced that:

“A gyroplane by the most common definition is any aircraft that is sustained by rotating surfaces, and may have either power driven or autorotating rotors. The rotors may utilize any of several methods of achieving lateral balance; and the method of achieving lateral balance has a large bearing on the range of usefulness of the aircraft, whether it is power or aerodynamically driven. A study will first be made of several types of balancing and the possibilities and limitations of each. The rotor alone will be discussed first.”

And while this wasn’t a traditional way of classifying rotorcraft, it functioned as a useful, if temporary, taxonomic approach and, as referenced by Hovgard, made use of the “theory of the autogiro as originated by Glauert¹⁹⁸ [who had also written previously on the helicopter¹⁹⁹] covers any rotor whether of the individually articulated type as used by Cierva, the interconnected type as used by Herick or the rigid feathering type used by Wilford.”

Having laid out the range of rotary wing aircraft rotor systems, Hovgard went on to assert that: “As far as performance alone is concerned there is theoretically no difference except that the interconnected flapping type is limited to an even number of blades. Other considerations therefore, must be brought out before choosing the type of rotor to adopt. For the purposes of discussion, the fact that the most logical rotor to choose now is the one on which the most development work has

been done, will simply be ignored; such a thought simply does not inspire the imagination enough.”

And with that disclaimer of popular choice, Hovgard proceeded to analyze the advantages and disadvantages of each of the delineated rotor systems. He saw the problem as:

“All three of the rotors possess the same high speed limitation, that is, the limitation imposed by the approach to the speed of sound and the disproportionately large increase in drag with increasing speed in that region. All three of the types or rotors named must maintain a ratio of blade tip speed to forward speed of about two to one. At that ratio only the outer half of the retreating blade is traveling relatively forward and part of that section is stalled. If the tip speed falls to less than twice the forward speed an intolerable roughness is encountered. That was brought the other day by Mr. Hafner. His speed limitation is not the performance of the rotor, or the lack of horsepower, but the roughness that comes into the rotor system, and that is a problem that is going to be with us more definitely than the attainment of the last degree of refinement in performance. . . . In a rotor, however, the tip of the advancing blade is moving faster than any other part of the aircraft and that is the part that will encounter the shock wave far ahead of anything else. The high drag at this point will produce such an intolerable roughness that higher speeds are impractical.”

Given this assertion, Hovgard turned to a convertiplane configuration as a way of achieving greater speed, stating that “[w]hen combined with a fixed wing, the Wilford type rotor has remarkable possibilities.” He continued:

“It will be found possible in some of the designs to attain higher speeds by using other means of sustentation for high speeds and the rotor only at low speeds. In the Herrick rotor, the blades when not rotating are the wing. Means may be found for starting and stopping the rotor at will, to provide greater speed ranges. Another method is to use rigid feathering blades in combination with a fixed wing, let the rotor carry the load at low speeds and idle

at high speeds while the wing carries the load. This principle is exemplified in the Wilford system. The individually articulated blades have the advantage of greater simplicity and lighter weight to offset the advantages of the other types at the high speeds. Articulated rotors, whether freely rotating or power driven, will dominate the lower speed field.

In aircraft with enough power that the speed range will be above about four, then for a given landing speed the Wilford gyroplane will be faster than a fixed wing airplane, even though the airplane be equipped with such high lift devices that the maximum lift coefficient is doubled. If this idea is carried to the extreme, the double rotors used and the engine connected to the propeller or rotors at will, the ultimate in performance will be reached; the machine will be capable of hovering and the high speed limitation will be the same as that of the fastest airplane. . . . As time goes on, means may be found to drive the rotors more simply and even to do away with one rotor, and possibly further to draw the rotor in side the body at high speeds. The basic principles underlying such a development are, however, inherent in the Wilford design. It was the author’s privilege to make the first extended flights in a rotary wing aircraft with blade control, and to have made the longest and highest flights made to date with rigid feathering blades. These flights were made in any early Wilford Gyroplane about six years ago.”^[200]

In dividing the future into lower and higher speed systems, it was apparent that Hovgard was taking a more sophisticated view than others had, and that there would be room for different approaches. He then advanced a comparison between rigid and articulated rotors in terms of response to control moments, and in doing so demonstrated the breadth of his consideration, which was considerably greater than those who had previously spoken:

“To produce moments about the pitching axis as in the articulated rotor as above the incidences of the front and rear blades must be changed. Unlike the articulated

rotor, the rigid rotor is not dependent upon lift for control. There may be a degree of danger in the articulated rotor, in that if the control column is moved suddenly forward, so much of the lift of the rotor may be eliminated that the control moment produced is negligible. The rigid rotor depends only upon rotation for control, and the control system is more sensitive when carrying more load. The rate of rotation, however, is generally much more nearly constant than the lift.

The above principle holds true regardless of the type of control mechanism employed in the system. The control in articulated systems had been placed in apparently all conceivable positions. Cierva was the first and placed the control below the support, thus tilting the whole hub. Herr Focke rates the next position with the control in side the hub, which moved the flapping hinge. Mr. [David] Kay ^[201] builds the control into the flapping hinge. There seems to be some agreement there. I noticed Mr. Platt said yesterday, the pitch change was made in the vertical pin. I had understood it was inside the rotor. I had understood it was inside the rotor. I have seen descriptions that showed that inside the rotor was a screw-jack that went up and down and raised one end of the horizontal pin, and I see Mr. Hafner nodding his head. And also, the control is manual, and is operated by the pilot with the rotor clutch, so when the clutch is engaged to rotate the rotor, the blade incidences of all six blades is increased at the same time, and that is all inside the head. The next position, in the extension block between the flapping and the vertical hinge, has not been used for flight control but has been used for some models for incidence control in jump-off. The last position, beyond the vertical hinge, is used by Mr. Hafner. In each case the choice is made from purely mechanical or patent considerations; aerodynamically the rotors are identical. One important item in favor of Mr. Hafner's design, however, is that the loads from the blade dampers are taken directly into the body of the machine, and not into the control system."

After showing a taxonomic approach that advanced a continuum ranging from Cierva to Hafner, Hovgard went on to discuss the advantages of rigid rotors. His analysis of the Focke machine are worth noting almost seven decades later. He opined:

"One of the most difficult steps in the evolution of the Helicopter is the direct application of the power into the rotor. The many methods available for torque reaction are very able presented in an article by Herr Focke describing the development of his machine.^[202] Most of the methods have been tried and others are being or will be tried. The Focke manner of arranging two articulated rotors side by side represents the Helicopter in its simplest and crudest form, and it is the logical first attempt at vertical flight, as has now been proven. For some uses it may represent the final form. Where hovering and vertical take-off and landing with complete control are important and high speed has no value, this arrangement has many advantages that will be difficult to better in any competing Helicopter.

I have heard reports since this is written that Focke is considering superimposed rotors for his next type. I rather lament that change, because of the great mechanical complexity involved, and also because it is my contention that if you can't make use of his crude form of helicopter than neither can you use one which merely has the advantage of having the rotors superimposed. I would rather see his design developed and its use determined before the next step is taken.

Incidentally, I read also a discussion by an obviously very pessimistic Englishman, made after he saw the flights of the Focke helicopter. He said that ordinarily, it would take about five years of development work to make it a useful machine, and then he applied a stupidity factor of three, which made it fifteen years before the helicopter would be useful. He didn't state whether the stupidity factor was on the part of Herr Focke, and I doubt if he mean that, but there is a stupidity factor in the case of people who will use the helicopter."

And, in agreement with Hafner, Hovgard concluded that “[t]he Focke design is cumbersome” and then considered the advantages and disadvantages of a coaxial configuration, which lead to a more general view of the future of rotary wing aircraft. He stated:

“It is the contention of the author, that the success of the Helicopter does not depend on whether it has rotors in parallel or one above the other, or whether the blades are rigid or articulated, but just “Does it Work?” and “Is it useful?” Progress is consistently made in steps but rarely in huge jumps. The first step was made by Cierva in producing the Autogiro and second step apparently is about to be made by Focke. The Autogiro was first made commercially available about nine years ago; improvements are still being made upon it, and will continue to be made on it for some time to come. In the meantime, the Focke type Helicopter will be developed, and will eventually be made available for Military and commercial uses; but it does not naturally follow that, as soon as the Helicopter is perfected, the Autogiro will become extinct. In fact, you could contend that the advent of the helicopter would first affect the field by increasing the popularity of the autogiro. In spite of all the airplanes there are still some automobiles left on the streets; even with the automobiles and tractors, there are still horses working; in fact, some people are even barbaric enough to walk from one place to another. . . . So anyone who contends that the helicopter is going to make the autogiro obsolete has no basis for such contention.”

But, of course, Hovgard was to be proven wrong as the Autogiro faded with the coming of the helicopter. As a 1944 article stated: “[y]es, the helicopter is reliable, adaptable, and equal to almost every situation. She seems to have her rival, the autogiro, quite outclassed.”²⁰³ And in the following year Dick Haymes may have sung to Helen Forest “a honeymoon in Cairo with a brand new autogyro . . . in the 1945 song “I’ll Buy That Dream”²⁰⁴ but there were no new Autogiros.

But that wasn’t known in 1938, and Wilford seemed to have trouble reacting to Hovgard’s talk.

He stated somewhat mysteriously: “It is fortunate that Paul Hovgard comes from Kansas, but he is mighty close to Missouri. But we are awfully happy in knowing that the aircraft industry is watching our feeble attempts, and let’s hope that we will have something so good before long, that there will be plenty of production.” And it may be that he was just catching his breath from the previous two presentations that had, in particular, taken Focke to task for the two-rotor design, so Wilford changed the order of presentation and inserted W. Laurence LePage, American advocate of the two-rotor configuration, to present “The Helicopter in Europe.”²⁰⁵ Wilford presented LePage’s credentials as “he is an advocate of the two-rotor helicopter. By the way, Brother LePage started as an engineer and then turned writer, and editor of “Aviation”, and besides that, he is a pilot.”

W. Laurence LePage²⁰⁶ was himself not presenting his own work, but had come to “give to you the views of two very prominent, fine engineers in this field of rotary wing development, and therefore, in spite of what Mr. Wilford says about his ideas of my preference in what I believe rotary wing aircraft should be, the remarks I have to make today have nothing whatever to do with my own views.”

LePage then proceeded to present a brief communication from Louis Bréguet and a copy of a paper “which many of you may have read on the helicopter.”²⁰⁷ Bréguet stated that he had reserved the term “Gyroplane” for a category of helicopter that eliminated the propulsive air screw by means of a forward inclined axis of rotation, stating in his communication with the meeting participants:

“I am firmly convinced that the autogiro solution marks only a provisional stage in the evolution of rotary wing aircraft, and that the pure helicopter will hold the sky in the future.” As LePage elaborated on Bréguet: “He elaborates upon that by saying that he is of the opinion that the helicopter will have a flexibility of use which will be superior to that of any other flying machine, permitting on one hand, hovering and vertical flight, and on the other hand, propulsion at a very high speed under particularly economical conditions. He gives two reasons to justify this statement: “No matter how efficient an autogiro may be, the loss of power due to the separate propulsive propeller will remain great. . . .

On the contrary, I have proved that the propulsive efficiency of a helicopter – of a gyroplane – always remains practically constant and equal, always remaining practically constant, and does not vary far from the optimum value, especially if the range of forward inclination of the axis does not exceed six or seven degrees.”

And LePage went on to present Bréguet’s second reason for preferring the helicopter, a mathematical proof of efficiency of the helicopter over the Autogiro, stressing that “the helicopter is at all times superior, in Mr. Bréguet’s opinion, to the autogiro, no matter what phase of flight is being considered.” He continued:

“Mr. Bréguet also points out that the autogiro is particularly efficient when the rotor is tilted back fourteen degrees. I presume he means during vertical or near vertical descent. And then he repeats again this condition in which the autogiro is being hauled through the air with its rotor tilted far back, as its principal source of lost efficiency, but the helicopter because its rotor is at all times tilted in the other direction, with the air-flow from the top of the disk to the bottom of the disk, results in a more efficient aerodynamic arrangement. He says that he has recently done some additional computations which have more than confirmed what we might consider to be his exaggerated optimism for the helicopter. Mr. Bréguet ends his message to us with a statement that in his opinion the helicopter has a tremendous future; that the autogiro has served, in his opinion, to emphasize the value, the essential value in his opinion, of the articulated type of rotor, and that aspect it will remain in the history of rotary wing aircraft as an outstanding contribution to this field. But he feels that it has already reached, or closely approaching, the limit of its capacity of improvement And he ends: “I thank you for having asked me for my views, and dear sir, please accept my deep regrets at not being able to be present.”

And on that note at once pessimistic towards the Autogiro and optimistic towards the helicopter, LePage turned to the communication from Professor

Heinrich K. J. Focke whose helicopter achievements with the Fa-61 were even then confronting the meeting participants.

LePage related that: “I wired to Professor Focke and told him of this meeting, and asked for his permission to express to you, as well as I was able, not only some comment on his work and his machine, but also such views as I would feel from my personal acquaintance with him that he would want me to say for him, and I had a very pleasant wire back from him, wishing this meeting great success.”

LePage continued:

“Professor Focke also started his profound interest in the helicopter through the agency and the means of his personal acquaintance with Juan de la Cierva, and his study of Cierva’s great works. He, too, came to the conclusion that the articulated rotor was the basis upon which he might expect to find a solution for vertical flight. As you know, all of you, the Focke Helicopter by sight and by name from pictures that you have seen, and I think the best way in which I can portray to you his work is the showing of a movie which was made especially for me while I was in Germany, by the many friends I met there, and through arrangements which Professor Focke made, which shows the machine under a number of different conditions of flight.”

And after commenting that Focke had increased the helicopter’s performance, LePage showed the film of its flight, noting *en passant* that “the Army Air Corps has seen this film, and feels that it is an item which should be included in the archives of aeronautical development, and they have therefore made a copy of the film and have it at Dayton, and they very kindly gave me a copy of my original film with English titles, which made it a little more convenient.”²⁰⁸

After the film, LePage was asked some questions as to its capabilities and queries about Dr. Focke (LePage responded that: “I think he [Focke] is about 45. He is a very likeable man”). He also described his 1937 trip to Germany, during which the Focke helicopter had been flown in the Deutschland-Halle, stating that:

“I feel that there is a justifiable excuse for this type of demonstration, although I per-

sonally should be very opposed to what appears to be a sort of fantastic stunt. It is justifiable, certainly, from an engineering point of view, because it demonstrates the perfectly remarkable and precise control that one has over this machine. The Deutschland-Halle is about two-thirds the size of Madison Square Garden, and while these pictures were taken in the morning when there were no people in the hall to speak of, the ship flew in the hall for six minutes every night for three weeks, in front of fifteen thousand people. You can imagine that if one were not quite positive of its reliability and control, it would be a very, very great hazard.”

When Wilford announced that there was no time left for discussion of the paper, he turned to the German Military Attache for comment (one wonders what the officer was thinking, having just heard that the films of the Focke helicopter were of interest to the American military – one suspects his thoughts did not incline to “archives of aeronautical development” and General Lieutenant Friedrich von Boetticher replied congenially: “Well, I just appreciate the splendid time I am having here in the United States. I have enjoyed it so much, as well as the very good friends I have made here.”²⁰⁹

Wilford then introduced the final meeting paper, “High Speed With Safety”²¹⁰ presented by Dr. Max M. Munk of Washington, D.C. Munk had begun his studies of aerodynamics with Dr. Ludwig Prandtl at Göttingen, and his work with its wind tunnel earned a doctoral degree. He was by 1938 well known for theoretical aerodynamics – a daunting achievement given that the German military had classified his WWI theoretical work. Monk had come to the United States in 1921 and eventually became chief aerodynamicist at the N.A.C.A. as well as receiving a university appointment at the Catholic University of America. He gained renown in America with *inter alia* the invention of the variable density wind tunnel in 1923. His presentation did not easily fit the program, and was clearly inserted towards the end for convenience, as it was not an obvious participant in the future of rotary wing aircraft.

As Monk noted, “this is a joint paper of a very strange combination. I made the whole paper, but I had nothing whatsoever to do with the title of the paper. . . . The title was very ably prepared by our Chairman, Mr. Wilford.” And in

continuing, it was evident that Monk was searching for a way to make the selected title relevant to the meetings, not an easy task as he himself observed: “As for the speed, of course it was almost the (sic) consensus of opinion that the present rotary wing aircraft is for low speed chiefly, and not for high speed. As for future hopes, desires, opinions and so forth, I do not want to make the mistake to say that a high speed is not possible, just because I may at this time not see, not be able myself to point out how it can be done.” And Monk went on to point out that it was possible to construct very slow-flying light airplane comparable to the performance of rotary wing aircraft – but that while such a light airplane would be susceptible to wind gust, the rotary wing aircraft would prove more robust under such conditions.

Monk concluded, with a dash of humor:

“That may be theory to you, but I have talked with several pilots and designers during the last day, and they all confirm to me that actually a rotary aircraft is much safer near the ground at low speed, and it is the only means from that standpoint to do it at all. The other thing [light aircraft] is not safe enough. Of course, this German plane [Focke Helicopter], they flew it in a hangar, inside. In America, we use escalators for that, and there are no gusts; then you can do it. That is not the problem. The problem is not to fly inside of a building, but outside of a building. So you see that in an indirect way, the great essential advantage of rotary aircraft is that it combines high speed of the lifting element with slow speed of translation, and in that way, brings out and reserves in a safe slow motion without ground – of course not for landing and take-off as some of the speakers suggested, for only for flying without ground. I think, therefore, that the slogan of rotary aircraft is very properly “high speed with safety.”

Wilford added: “Well, we have ended our session exactly on time, even though we started late. But I do want to say one thing, that I think Dr. Monk has given us a wonderful slogan, and it proves he is not only an Einstein of aerodynamics, but an Einstein of philosophy.” And with that, the meetings adjourned, and as recounted in Appendix I (authored by Ralph H. McClarren, AeE. The Franklin Insti-

tute) “[a]bout 70% of the 242 total registered at the meetings saw John M. Miller put a Kellett KD-1 autogiro through its paces. He produced some spectacular flying from the direct-control, wingless Autogiro, making very quick take-offs, almost vertical climbs, practically hovering against the (sic) wing [more correctly, “against the wind”] and landing without rolling a wheel. Also, a fine demonstration of Crop Dusting was made by George Townson, flying one of the Giro Associates Pitcairn Model P.C.A.– 2 Autogiros. It exemplified the use of rotating wing aircraft in the important field of agriculture.”

Appendix II of the Conference Proceedings contained a reprint of Hafner’s paper, to which he and had referred: “An Investigation into the Problem of the Rotor Torque of a Helicopter” (as cited *supra*).

Conclusion – An Historic Gathering

These meetings, consisting of invited papers based on topic assigned by Chairman E. Burke Wilford (presumably in consultation with others, notably Dr. Ralph McClarren), were a genuinely historic gathering. There is little evidence of the Frank Kingston Smith asserted conspiracy against the Autogiro in general, and the Autogiro Company of America specifically. Jay Spenser’s view of this as a battlefield between Autogiro/gyroplane and helicopter comes closer to a broad brush characterization of the antagonistic dynamic between the two camps. But given the two significant presentations, complete with surprise comments on the state of his helicopter development, there is little doubt that Raoul Hafner placed an indelible stamp on the proceedings which was forcefully reinforced and independently echoed by Europeans Bréguet and Focke, and Americans Paul Hovgard and H. Franklin Gregory. The combined impact of their presentations and the arguments contained therein pointed directly and undeniably towards the helicopter. And given the views of Lt. H. Franklin Gregory, who had come to the meetings convinced that the Autogiro was only a way station on the highway leading inextricably to the helicopter, and who was soon to oversee the dispersal of Dorsey-Logan funds, first to the Platt LePage helicopter, and then to Igor Sikorsky’s single rotor design, the meetings could not but have reinforced his beliefs. Those in the audience advocating the Autogiro, though they could not have positive knowledge, could justly have left the meetings with the suspicion that their

cause was already lost.

¹ New York: Jason Aronson, 1981

² Seattle and London: University of Washington Press 1998

³ For authors who fail to mention the 1938 meeting, see e.g., Gablehouse, Charles. *Helicopters and Autogiros: A History of Rotating-Wing and V/STOL Aviation*. Rev. ed. Philadelphia: Lippincott, 1969; Aellen, Richard “The Autogiro and Its Legacy” *Air & Space Smithsonian*. Washington, D.C. December 1989/January 1990 pp. 52 – 59; Anders, Frank “The Forgotten Rotorcraft Pioneer: Harold F. Pitcairn.” *Rotor & Wing International* May 1990 pp. 34 – 37 reprinted as “The Forgotten Rotor” *Rotorcraft* Vol. 28 No. 7 October-November 1990 pp. 30 – 34); Gunther, Carl F. “Autogiro” Parts I and II *Popular Rotorcraft Flying* Vol. 17 No. 5 October pp. 6 – 14 and Vol. 17 No. 6 December 1979; reprinted in *Private Pilot*. Vol. 15 No. 9 September 1980 pp. 38 – 45; Vol. 15 No. 10 October 1980 pp. 38 – 45. See also Gunther’s “Rediscovering Harold Pitcairn” Astman Distinguished Address - paper presented at the *From Autogiro to Gyroplane: The Past, Present and Future of an Aviation Industry Conference* at Hofstra University April 25 – 26, 2003 which is printed in Charnov, Bruce H. and David Klein (eds.) *FROM AUTOGIRO TO GYROPLANE CONFERENCE PROCEEDINGS*. Hempstead, NY: Hofstra University 2004; Townson, George. *Autogiro: The Story of ‘the Windmill Plane’*. Fallbrook, California: Aero Publishers (1st ed.); Trenton, New Jersey: Townson, 1985 (2nd printing); Fay, John. *The Helicopter*. New York: Hippocrene Books, 4th ed., 1987; Jackson, Robert. *The Dragonflies: The Story of Helicopters and Autogiros*. London: Barker, 1971

⁴ Gregory, Hollingsworth Franklin. *Anything a Horse Can Do: The Story of the Helicopter*. Introduction by Igor Sikorsky. New York: Reynal & Hitchcock, 1944. Revised editions were published as: *The Helicopter; or, Anything a Horse Can Do*. New York: Reynal & Hitchcock, 1948; Lon-

don: George Allen & Unwin 1948 and *The Helicopter*. (South Brunswick, New Jersey: A. S. Barnes, 1976)

⁵ LePage, Wynn Laurence *Growing Up With Aviation*. Ardmore, PA: Dorrance & Company, Incorporated, 1981

⁶ For a brief history of the involvement of the Franklin Institute with manned flight, see Trimble, William F. *High Frontier: A History of Aeronautics in Pennsylvania*. University of Pittsburgh Press 1982 pp. 17, 52, 180

⁷ Spenser, Jay P. *Whirlybirds: A History of the U.S. Helicopter Pioneers*. pp. 94 – 95

⁸ Indeed, Smith goes on to assert that the subsequent crash of the Pitcairn XR-9B experimental helicopter at the hands of the Army acceptance test pilot was a deliberate act. See Smith, Frank Kingston. *Legacy of Wings: The Story of Harold F. Pitcairn*. New York: Jason Aronson, 1981 pp. 312 -313

⁹ Actually, Hafner was Austrian then living in England. With the advent of WWII in the following year, he would be briefly interred by the English as a foreign national, be offered and accept English citizenship, and actively contribute to the war effort with the Hafner Rotachute and 'Rotabuggy'.

¹⁰ Note that Smith is mistaken as the Vought-Sikorsky Division is located, as noted by H. Franklin Gregory in his writings, in *Stratford*, Connecticut.

¹¹ Smith, Frank Kingston. *Legacy of Wings: The Story of Harold F. Pitcairn*. p. 264

¹² Sikorsky, Sergei "The Dorsey Controversy" *Flight Journal*. Vol. 8 No. 2 April 2003 pp. 97 – 98; see also "The Dorsey Bill: Collusion or Delusion" paper presented at the *From Autogiro to Gyroplane: The Past, Present and Future of an Aviation Industry* Conference at Hofstra University April 25 – 26, 2003 printed in Charnov, Bruce H. and David Klein (eds.) *FROM AUTOGIRO TO GYROPLANE CONFERENCE PROCEEDINGS*. Hempstead, NY: Hofstra University 2004

¹³ For historical background on the N.A.C.A., see Gustafson, F. B. "A History of NACA/NASA Rotating-Wing Aircraft Research, 1915 – 1970" Limited-Edition Reprint (VF-70) from *Vertiflite*, American Helicopter Society, Alexandria, VA 1971; see also "The National Advisory Committee for Aeronautics" included in Abbot, D.Sc., Charles Greeley *Great Inventions*. Washington, D.C.: The Smithsonian Institution Series (formerly Smithsonian Scientific Series) (Vol. 12) 1949 pp. 233 – 238

¹⁴ Gregory, Hollingsworth Franklin. *Anything A Horse Can Do: The Story of the Helicopter* p. 105

¹⁵ Internal evidence on p. 1 of the *Proceedings* suggests that this acknowledgement was delivered by E. Burke Wilford, President of the Philadelphia Chapter of the Institute of the Aeronautical Sciences.

¹⁶ See Glines, C. V. "The Guggenheims: Aviation Visionaries" *Aviation History*. November 1996 pp. 26 – 32, 70 71, 76.

¹⁷ Klemin, who had immigrated to the United States in 1912, had received a B. S. (with honors) from the University in London in 1909. He completed the M.S. in Aeronautical Engineering at M.I.T. in 1915. Naturalized in 1917, he would receive an LL.D. from Kenyon College (Ohio) in 1934. His pioneering work included teaching the first aeronautics course in America at New York University 1919 – 1925, was at the time of the Franklin Institute meetings the Director (with the rank of Professor) of the Guggenheim School of Aeronautics (1925 – 1945), and had just taught the first course on the theory of rotary wings in the world in 1937. *Aero Digest* would laud his efforts at the Guggenheim School in March, 1950 thusly: "his inspiration and untiring efforts; he brought the reputation of the institution to top-ranking position in this country" and he was instrumental in the founding of the American Helicopter Society.

¹⁸ For reference to the donation of the PAC-1A to the Franklin Institute, see Brooks, Peter W. *Cierva Autogiros: The Development of Rotary-Wing Flight* p. 123. It was subsequently donated to the Smithsonian, restored by Harold F. Pitcairn's son Stephen, and placed an exhibit loan at the American Helicopter Museum & Education Center. See "Ex-

hibit Spotlight: Pitcairn PCA-1A” *Vertika*. Vol. 7 Issue 2 October 2000 p. 5

¹⁹ Brooks, Peter W. *Cierva Autogiros: The Development of Rotary-Wing Flight*. p. 121

²⁰ Boyne, Walter J. *The Aircraft Treasures of Silver Hill*. New York: Rawson Associates, 1982 p. 134 - 135; *see also* Brooks, Peter W. *Cierva Autogiros: The Development of Rotary-Wing Flight*. pp. 190 – 191

²¹ The Autogiro Company of America itself claimed in 1932 that the first Autogiro flight occurred *both* on December 18th and 19th. *See* “The Autogiro” Philadelphia: Autogiro Company of America 1932 p. 15; “Some Facts of Interest About Rotating-Wing Aircraft and the Autogiro Company of America” Philadelphia: The Autogiro Company of America 1944 p. 12 (caption to top photo). But these accounts cannot be regarded as definitive as *the 1932 publication contradicts itself* in stating on p. 31 “It was flown for the first time over American soil by Mr. Pitcairn, at Bryn Athyn, on December 18, 1928.” There is also some confusion about the pilot in the first flight. Frank Kingston Smith apparently is not the only source for the claim that Pitcairn made the first flight on December 18th. The 1932 and 1944 publications by the Autogiro Company of America cite the 19th and, being silent as to the pilot, neither attributes that flight to Pitcairn. Brooks and Townson date that flight on the 19th, and each relates that Cierva pilot Arthur Rawson first made a test flight after the C.8W had been re-assembled – a sensible procedure probably agreed upon by both parties – and in describing the first flight(s) Smith at first relates ambiguously that “. . . the first Autogiro made its first flight. Harold Pitcairn was the first American pilot to fly it” which, while factually true, obscures the fact that Rawson made the first flight. The accompanying photo on the same page (149) is captioned “An historic photograph: the first rotary-wing flight in America, with Harold Pitcairn flying the Cierva C-8 Autogiro at Willow Grove in December, 1928” is also historically accurate – it was the first a photo of Pitcairn’s first American flight – but clearly not the first American flight. That honor had been claimed by Rawson. *See also* Brooks, Peter W. *Cierva Autogiros: The Development of Rotary-Wing Flight*. p. 77; Townson, George. *Autogiro: The Story of ‘the Windmill Plane’* p. 15; Smith,

Frank Kingston. *Legacy of Wings: The Story of Harold F. Pitcairn*. New York: Jason Aronson, 1981 p. 149. The apparent controversy was definitively solved in 2005 when, in the midst of a box of Pitcairn aviation historical film reels provided by Harold F. Pitcairn’s son Stephen, Dr. Bruce Charnov discovered a ‘lost’ film that clearly showed Arthur Rawson making the first American Autogiro flight followed by Harold F. Pitcairn. The dubious claim of W. Laurence Lepage that the first Autogiro flight had actually been made on December 17, 1928, the 25th anniversary of the Wright brothers historical flight, and other accompanying details (he is the only source claiming that Agnew Larsen, W. Laurence Le-Page, James G. “Jim” Ray and Geoffrey Childs *also flew* in the C.8W that day!) must not be accorded credibility, probably due to LePage’s memory lapse when recounting the event 54 years later! *See* LePage, Wynn Laurence *Growing Up With Aviation*. p. 105

²² For a photo of the C.8W flying over Bryn Athyn, *see* Townson, George. *Autogiro: The Story of ‘the Windmill Plane’*. Fallbrook, California: Aero Publishers (1st ed.); Trenton, New Jersey: Townson, 1985 (2nd printing) p. 13; *see also* Harold Pitcairn flying the C.8W. Smith, Frank Kingston. *Legacy of Wings: The Story of Harold F. Pitcairn*. New York: Jason Aronson, 1981 p. 158

²³ For a photograph of the acceptance, *see* “The Autogiro.” *Autogiro Company of America*. 1930, 1932 p. 29 (1932 ed.)

²⁴ Boyne, Walter J. *The Aircraft Treasures of Silver Hill*. pp. 135 –136 (*See* photo of deteriorating C.8W in 1982)

²⁵ *See* Charnov, Bruce H. “America’s First Rotary-Wing Aircraft: Missing in Action” *Rotorcraft*. Vol. 41 No. 8 December-January 2004 pp. 10 – 13; Boyne, Walter J. *The Aircraft Treasures of Silver Hill*. pp. 132 – 136

²⁶ As noted in *Aero Digest* Vol. 17 No. 7 December 1930 p. 64

²⁷ For a photograph of the Wilford Gyroplane, *see* Johnston, S. Paul. *Horizons Unlimited: A Graphic History of Aviation*. New York: Duell, Sloan and Pearce, 1941 p. 179

²⁸ For information on the Wilford Gyroplane, see Daland, Elliot "Wilford Gyroplane" *Aviation*. January 1941 p. 42; "Newest Wilford Gyroplane Safety" *Aviation Engineering Magazine*. September 1932; "The Wilford Gyroplane" *Aero Digest*. Vol. 25 No. 2 February 1932 pp. 56 – 57; "The Wilford Gyroplane" *Aero Digest*. Vol. 26 No. 12 December 1933; "The Wilford Gyroplane" *Aviation*. January 1938

²⁹ Brooks claims that the test pilot who died was J. S. McCormac. Brooks, Peter W. *Cierva Autogiros: The Development of Rotary-Wing Flight*. p. 23

³⁰ Ray, James G. "Commercial Uses of Rotary Wing Aircraft" *Proceedings of Rotating Wing Aircraft Meeting*. The Franklin Institute. Philadelphia, PA, Oct. 28 – 29, 1938 pp. 63 – 69

³¹ For information about the PA-36 and Agnew Larsen's role in this project, see "Pitcairn Model PA-36 Direct Control Autogiro" *Aero Digest*. September 1940; Rose, Donald R. "Pitcairn Model PA-36 Direct Control Autogiro" *Aero Digest*. P. 104, 119; Zazas, James B. *Visions of Luscombe: The Early Years*. Terre Haute, IN: SunShine House, Inc. 1993; Larsen, Agnew E. "American Autogiro, Gyroplane and Early Convertiplane Developments" *Journal of the American Helicopter Society*. Vol. 1 No. 1 January 1956 pp. 6 – 15; Larsen, Agnew E. "Pitcairn Whirlwing" *Aviation*. Vol. 39 No. 9 September 1940 pp. 46 – 48; Smith, Frank Kingston "Mr. Pitcairn's Autogiros" *Airpower* Vol. 12 No. 2 March, 1983 pp. 28 – 49

³² Smith, Frank Kingston. *Legacy of Wings: The Story of Harold F. Pitcairn*. pp. 266 – 267

³³ Wilford, E. Burke "Introduction" *Proceedings of Rotating Wing Aircraft Meeting . . . October 28 and 29, 1938*. Philadelphia : Institute of Aeronautical Sciences 1938 Sponsored by the Philadelphia Section, Institute of the Aeronautical Sciences p. 2

³⁴ For photographs of the Fa-61 (also called the Fw-61), see Gregory, Hollingsworth Franklin. *Anything A Horse Can Do: The Story of the Helicopter*. p. 59; Francis, Devon, Earl. *The Story of the Helicopter*. New York: Coward-McCann, Inc., 1946 facing p. 70 (photo by W. Lawrence LePage); Hollmann, Martin *Flying the Gyroplane* Monterey, CA: Aircraft Designs, Inc., 1986 p. 29

³⁵ As cited by Martin Hollmann in the introduction to *Helicopters*, the second prototype Fa-61 (D-EKRA) established the following F.A.I. world records for helicopters:

25/26 June 1937 (pilot Ewald Rohlf)

m 2,439 (8,001 ft.) altitude
m 1 hr. 20 min. endurance
m 80.6 km (50 miles) distance in a straight line
m 122.5 km (76.1 miles) distance over a closed circuit
m 16.4 km/hr (10.1 m.p.h. speed over a closed circuit

25 October 1937 (pilot Hanna Reitsch)

m 108.97 km (67 miles) distance in a straight line

20 June 1938 (pilot Karl Bode)

m 230.3 km (143 mountains) distance in a straight line

29 January 1939 (pilot Karl Bode)

m 3,437 m (11,243 ft) altitude

³⁶ For photographs of Hanna Reitsch flying inside the arena in Berlin, see Gablehouse, Charles. *Helicopters and Autogiros: A History of Rotating-Wing and V/STOL Aviation*. p. 67 (note that the caption of the photo is misleading)

³⁷ See Young, Warren R. *The Helicopters*. Alexandria, Virginia: Time-Life Books 1982 p. 74 (photograph of Reitsch conferring with Focke before the exhibition flights)

³⁸ Ingalls, David S. "Autogiros – Missing Link" *Fortune*. March 1931 pp. 77 – 83, 103 – 104, 106, 108, 110

³⁹ Carroll, Thomas "Relative Flight Safety of the Autogiro" *Aero Digest*. Vol. 17 No. 7 December 1930 p. 72

⁴⁰ "Autogiros of 1931 - 1932" *Fortune*. March 1932 pp. 48 – 52, p. 48

⁴¹ On Earhart, see Meyer, Shirley "Amelia Earhart, Autogiro Pilot." *Popular Rotorcraft* Vol. 16 No. 66 December 1978 pp. 16 – 17; Charnov, Bruce H. "Amelia Earhart, John M. Miller and the First Transcontinental Autogiro Flight in 1931" published at <http://www.aviation-history.com/airmen/Amelia-Earhart-Autogiro.htm> January 2003; "Amelia Earhart and the PCA-2: A Re-evaluation of the First Woman Autogiro Pilot." *FlyGyro!* January/-February 2001 pp. 4 – 6

⁴² "Autogiros of 1931 - 1932" *Fortune* March 1932 p. 52; See also *Aero Digest* Vol. 17 No. 7 December 1930 p. 73 advertising "Real Airplane Bargains" with prices ranging from \$975.00 to \$2,595.

⁴³ "Autogiro in 1936." *Fortune*. Vol. XIII No. 3 March 1936 88 – 93, 130 – 131, 134, 137

⁴⁴ "Autogiro in 1936." *Fortune*. p. 93

⁴⁵ Miller, John M. "Civil Uses of the Autogiro." *Aeronautics* National Aeronautics Council Vol. II No. 10 November 6, 1940 pp. 611 – 624

⁴⁶ Lunde, Prof. Otto H. "Development and Operation of the Autogiro" *Aeronautics* National Aeronautics Council Vol. II No. 9 October 30, 1940 pp. 548 – 562

⁴⁷ See also the November 1931 *National Glider and Airplane News* (cover featuring a Cierva Autogiro passing near the Eiffel Tower)

⁴⁸ While the scene depicted is unrealistic, it would be repeated in the Autogiro rescues included in the 1988 film "The New Adventures of Pippi Longstocking" and the 1991 film "The Rocketeer". For information on the latter, see Vaz, Mark Cotta "Rocket Blast" *Cinefex*. No. 48 November 1991 pp. 20 – 45

⁴⁹ "Double Gyroplane Has Speed and Power" *Popular Science*. Vol. 125 No. 2 August 1934 p. 47

⁵⁰ Miller, John M. "The Missing Link in Aviation" *Popular Mechanics Magazine*. Vol. 70 No. 3 September 1938 pp. 346 – 351. 134A- 135A (reprinted *Homebuilt Rotorcraft*. Vol. 5 No. 7 July

1992 pp. 4 – 6; 12 – 14; reprinted *Homebuilt Rotorcraft*. Vol. 9 No. 1 January 1996 pp. 4 – 6; *Homebuilt Rotorcraft*. Vol. 15 No. 11 November 2002 pp. 14 – 16

⁵¹ A film of the Champion Spark Plug Company Pitcairn PCA-2 Autogiro "Miss Champion" (NC11609), flown by Lewis A. "Lew" Yancey flying to Cuba, the Yucatán, and Glacier National Park. See "Captain Yancey Explores Mayan Ruins by Autogiro" *Autogiro News*. Autogiro Company of America. February 1932

⁵² The only surviving copy of this film, showing the de Havilland Cierva C.L. 24 Autogiro in flight, is in the British Film Institute (BFI)

⁵³ For information about the character of King Westly, the "Autogiro pilot" in this film, see Carney, Ray *American Vision: The Films of Frank Capra*. Hanover, NH: Wesleyan University Press 1986 p. 233

⁵⁴ See Walker, Bud "People & Planes: Captain John Miller" *Aviation History*. Vol. 7 No. 2 November 1996 pp. 14, 16, 18; Abbott, Paul Bergen "Flying the 'Windmill Plane' With Johnny Miller" *Popular Rotorcraft Flying*. Vol. 24 No. 6 December 1986 pp. 18 – 20

⁵⁵ Adams, Eustace L. *The Flying Windmill*. New York: Grosset & Dunlap 1930

⁵⁶ Anderson, John *Wonders of the Air*. London: Humphrey-Milford, Oxford University Press 1937

⁵⁷ Gorman, Major J. T. *Gorilla Gold*. London, England: Blackie & Son Limited 1937

⁵⁸ Kalep, Elvy *Air Babies*. (forward by Amelia Earhart) Akron, OH: The Saalfield Publishing Company 1936

⁵⁹ Lavell, Edith *Linda Carlton's Island Adventure*. New York: The Saalfield Publishing Company 1931

⁶⁰ Hardy, Marjorie *Sally and Billy in Winter*. Chicago: Wheeler Publishing Company 1933

⁶¹ Cowell, Cyril *My First Book of Aeroplanes, Ships and Trains*. London, England: Thomas Nelson & Sons 1935

⁶² Shanks, Edward *The Dark Green Circle*. Indianapolis, IN: Bobbs-Merrill 1936

⁶³ See e.g., Seyfert, Ella Maie *Little Amish Schoolhouse*. New York, NY: Thomas Y. Crowell 1939; Heming, Jack *The Lost World of the Colorado*. London, England: Frederick Warne and Co. Ltd. 1940; Drummond, V. H. *The Flying Postman*. Porpoise 1948; Kurland, Michael *Too Soon Dead*. New York: St. Martins Press, 1997

⁶⁴ McClarren had earned a bachelor's degree in Engineering science from the University of Washington in 1928, and received an advanced degree in aeronautical engineering the following year from New York University where he studied under Dr. Alexander Klemin. He joined the Kellett Autgiro Company and would go on to become the chief engineer of the Herrick Convertiplane Corporation. He would be the main consultant to the Autogyro Company of America (later, after the death of Harold F. Pitcairn in 1960, Stephen Pitcairn would be substituted as Plaintiff) in its successful patent infringement lawsuit against the United States government for infringing ACA patents in helicopter design. Long after the passing of the Autogyro from the American scene, McClarren would serve two terms as mayor of Bryn Athyn, PA, passing away at the age of 87 on April 1, 1994.

⁶⁵ McClarren, Ralph H. "Review of Rotating Wing Aircraft" *Proceedings of Rotating Wing Aircraft Meeting*, The Franklin Institute. Philadelphia, PA, Oct. 28 – 29, 1938 pp. 2 – 5

⁶⁶ In a similar manner, Wing Commander Ken Wallis RAF (Ret) often begins his history of the autogyro with reference to the sycamore seed. See e.g., 1986 "The Aircraft of Ken Wallis" BBC

⁶⁷ See Sir George Cayley's design for a flying toy, based on the Chinese top. Young, Warren R. *The Helicopters*. p. 21

⁶⁸ McClarren, Ralph H. "Review of Rotating Wing Aircraft" *Proceedings of Rotating Wing Aircraft Meeting*, The Franklin Institute. Philadelphia, PA, Oct. 28 – 29, 1938 pp. 2 - 5

⁶⁹ For information on the 11EA, see Andersson, Lennart *Soviet Aircraft and Aviation 1917 – 1941*. Annapolis, MD: Naval Institute Press 1994 (first published London, England: Putnam Aeronautical Books) p. 335; See Everett-Heath, John *Soviet Helicopters: Design, Development and Tactics*. London: Jane's Publication Company 1983 pp. 11 – 12 (diagram on 12); Gunston, Bill *The Osprey Encyclopedia of Russian Aircraft*. Oxford, England: Osprey Publishing Limited, 1995, 2000 p. 66 (there listed in the section labeled CAHI); Char-nov, Bruce H. "Autogyros in the Soviet Union During WWII" *Homebuilt Rotorcraft*. Vol. 15 No. 11 November 2002 pp. 8 - 10

⁷⁰ Everett-Heath, in an otherwise outstanding book, comments on the 11 EA: "Why the word 'autogyro' was used to describe a helicopter is not known" seemingly oblivious to the origins of the design and ignoring that the aircraft was intended as a convertiplane, taking off and landing as helicopter but flying as an autogyro. See Everett-Heath, John *Soviet Helicopters: Design, Development and Tactics*. 1983 p. 5

⁷¹ For a description and history of Curtiss Motors, see Gunston, Bill *World Encyclopedia of Aero Engines*(4th ed.). Sparkford. Nr. Yeovil, Somerset: Patrick Stephens Limited, 1998 pp. 49 - 50

⁷² Everett-Heath *Soviet Helicopters: Design, Development and Tactics* London: Jane's Publication Company 1983 pp. 11 - 12

⁷³ Andersson, Lennart *Soviet Aircraft and Aviation 1917 – 1941*. p. 335

⁷⁴ See Everett-Heath *Soviet Helicopters: Design, Development and Tactics* pp. 146 – 147.

⁷⁵ H. Franklin Gregory recounts that he and test pilot Eric Snowdon Nichols, brother of famed woman aviator Ruth Nichols, were the army pilots assigned to evaluate the Kellett YG-1 (military designation for the KD-1) at NACA in early 1936. There they met with Wallace W. Kellett and chief engineer Richard H. Prewitt and company test pilot Lou Levy (later Leavitt). They came to question the army pilots as to a military impression of the Autogyro as Kellett was then as serious about the military market as Pitcairn was about the civilian area. Gregory and Nichols found flying lessons with Levy to be particularly instructive as he was by

then, with Jim Ray, one of the most experienced Autogiro pilots in America, but they also enjoyed the conversations with Prewitt. He described the aircraft's design and construction, wonderfully informative for Gregory who would later make the decisions that would doom the Autogiro. The pilots called Prewitt, who had actually designed the YG-1, "Daddy of this Whirligig". Gregory, Hollingsworth Franklin. *Anything A Horse Can Do: The Story of the Helicopter*. p. 55; for an additional account of Army testing of the Autogiro, see Gregg, E. Stuart "Jump Ship." *Smithsonian Air & Space*. Vol. 15 No. 6 March 2001 pp. 14 – 15

⁷⁶ "The Autogiro" *Proceedings of Rotating Wing Aircraft Meeting . . . October 28 and 29, 1938*. Philadelphia : Institute of Aeronautical Sciences 1938 Sponsored by the Philadelphia Section, Institute of the Aeronautical Sciences pp. 6 – 10

⁷⁷ See e.g., Smith, Frank Kingston. *Legacy of Wings: The Story of Harold F. Pitcairn*. pp. 261 – 264

⁷⁸ It should not be forgotten that Harold F. Pitcairn *did not* attend the 1938 Franklin Institute meetings as he was sick in bed at the time.

⁷⁹ Cierva, Juan de la and Don Rose. *Wings of Tomorrow: The Story of the Autogiro*. New York: Brewer, Warren & Putnam 1931

⁸⁰ Brie, R.A.C. *The Autogiro and How to Fly It*. London: Sir Isaac Pitman & Sons, 1933 2d. ed. 1935

⁸¹ Sanders, C. J. and A. H. Rawson. *The Book of the C.19 Autogiro*. London: Sir Isaac Pitman & Sons, 1931

⁸² The information on the Autogiro Company of America mirrored, however briefly, that which the company itself had previously published. See e.g., *The Autogiro*. Philadelphia: Pitcairn-Cierva Autogiro Company of America, 1930; 1933

⁸³ Prewitt, Richard H. "Possibilities of the Jump Take-Off Autogiro." *Journal of the Aeronautical Sciences* Vol. 6 No. 1 November 1938 pp. 10 – 14

⁸⁴ See Howe, Richard "Kellett KD-1/YG-1 Autogyro (Photo Essay)." *American Aviation Historical Society Journal*. Vol. 23 No. 1 1st. Quarter 1978 pp. 49 – 50; "Kellett KD-1 Autogiro" *Aero Digest*. December 1934; Brooks, Peter W. *Cierva Autogiros: The Development of Rotary-Wing Flight*. pp. 229 – 231

⁸⁵ On Herrick, see "The Herrick Vertaplane" *Aviation Engineering Magazine*. January 1932; Townson, George "The Herrick Convertaplane" *American Helicopter Museum & Education Center Newsletter* Vol. 4 No. 3 3rd Quarter 1997

⁸⁶ Herrick, Gerard P. "The Development of the Convertoplane" paper reprinted in *1st Convertible Aircraft Congress Proceedings*. (Sponsored by the Philadelphia Sections of the American Helicopter Society and the Institute of Aeronautical Sciences in Philadelphia, PA on December 9, 1949) pp. 83 – 89

⁸⁷ Herrick, Gerard P. "The Convertaplane" *Proceedings of Rotating Wing Aircraft Meeting . . . October 28 and 29, 1938*. Philadelphia : Institute of Aeronautical Sciences 1938 Sponsored by the Philadelphia Section, Institute of the Aeronautical Sciences pp. 11 – 22:11

⁸⁸ Davis, Al F. "One Of Our Simple Problems" *Proceedings of Rotating Wing Aircraft Meeting . . . October 28 and 29, 1938*. Philadelphia : Institute of Aeronautical Sciences 1938 Sponsored by the Philadelphia Section, Institute of the Aeronautical Sciences p. 12 reprinted in Herrick, Gerard P. "The Development of the Convertoplane" paper reprinted in *1st Convertible Aircraft Congress Proceedings*. (Sponsored by the Philadelphia Sections of the American Helicopter Society and the Institute of Aeronautical Sciences in Philadelphia, PA on December 9, 1949) pp. 83 – 89

⁸⁹For photographs of the Herrick aircraft models, see Boyne, Walter J. *The Aircraft Treasures of Silver Hill* p. 140 – 142; Gablehouse, Charles. *Helicopters and Autogiros: A History of Rotating-Wing and V/STOL Aviation*. p. 141; Townson, George "The Herrick Convertaplane" *American Helicopter Museum & Education Center Newsletter* Vol. 4 No. 3 3rd Quarter 1997 pp. 3 – 4; Boyne, Walter J. and Donald S. Lopez *Vertical Flight*.

Washington, D.C.: Smithsonian Institution Press, 1984 p. 175

⁹⁰ In a similar manner, the later Hafner Rotachute, Rotabuggy and Bensen Gyrocopter would also make use of a teetering-hinge 2-blade rotor system. See e.g. re: Hafner Rotachute: The Hafner Rotachute” *Aeroplane Monthly*. Vol. 19 No. 8 Issue 220 August 1991 pp. 470 – 476; Bensen, Igor “Rotachute, Rotary Wing Glider-Kite.” General Electric Co., Report No. 33200. Schenectady, NY: 1946; Hollmann, Martin “The Rotachute” *Gyroplane World*. Issue 7 April 1977 1 – 3; “The “Rotachute” and “Rotabuggy”” *Popular Rotorcraft Flying*. Vol. 19 No. 1 February 1981 pp. 14 – 15, 20 – 21; “The Hafner Rotachute.” *Fly Gyro!* No. 3 February 2001 pp. 18 – 19; “Design Classroom.” *Collected Works of Design Classroom*. California: Popular Rotorcraft Association 1974 p. 11; Brooks, Peter W. *Cierva Autogiros: The Development of Rotary-Wing Flight*. pp. 286 – 287; Bartlett, Ron “Gyroplanes – The Early Years” *International Autogyro 1/4ly*. Issue 5 p. 13 (author’s photograph of the Rotachute exhibited at the Army Air Corps Museum at Middle Wallop, England); Lambermont, Paul M., and Anthony Pirie. *Helicopters and Autogyros of the World*. Rev. ed. New York: A. S. Barnes 1970; London: Cassell, 1958, 1970 Previous edition: New York: A. S. Barnes: 1959 Introduction by Igor Sikorsky pp. 130 – 131 (there called the Hafner Rotaplane); “Lovegrove, Peter *Gyroplane Miscellavia* Volume 6 England: The British Rotorcraft Association April 2005 p. 111 (photo); Jones, Barry “Swords – and Ploughshares: A History of British Military Specifications” *Aeroplane*. Vol. 34 No. 1 January 2006 pp. 54 – 58; see also re: Hafner Rotabuggy: Everett-Heath, John *British Military Helicopters*. London, England: Arms and Armour Press Limited 1986 pp. 23 – 24; “The “Rotachute” and “Rotabuggy”” *Popular Rotorcraft Flying*. Vol. 19 No. 1 February 1981 pp. 14 – 15, 20 – 21; “The Hafner Rotachute.” *Fly Gyro!* No. 3 February 2001 pp. 18 – 19; “Design Classroom.” *Collected Works of Design Classroom*. California: Popular Rotorcraft Association 1974 p. 11; Brooks, Peter W. *Cierva Autogiros: The Development of Rotary-Wing Flight*. pp. 286 – 287; Bartlett, Ron “Gyroplanes – The Early Years” *International Autogyro 1/4ly*. Issue 5 p. 13 (author’s photograph of the Rotachute exhibited at the Army Air Corps Museum at Middle Wallop, England); 1999 “The Big Rigs of

Combat – Jeeps” (The History Channel) (Rotabuggy); Bensen, Mary de *Mount Up With Wings*. London, England: Hutchinson 1960 p. 139; Jones, Barry *Swords – and Ploughshares: A History of British Military Specifications” Aeroplane*. Vol. 34 No. 1 January 2006 pp. 54 - 58



⁹¹ See Mondey, David (ed *The Complete Illustrated Encyclopedia of the World’s Aircraft*. Secaucus, New Jersey: Chartwell Books, Inc. 1978 updated by Taylor, Michael as *The New Illustrated Encyclopedia of Aircraft*. 2000 p. 287

⁹² <http://www.therylesw.com/ghost>

⁹³ See Brooks, Peter W. *Cierva Autogiros: The Development of Rotary wing Flight*. p. 23 – 26 (photo on p. 25)

⁹⁴ “A post-crash examination revealed that, when the upper wing unlocked, it teetered hard against its bearings, broke them, and struck the propeller. The pilot attempted to bail out, but his parachute failed to open properly, resulting in his death.” See <http://www.nasm.si.edu/-research/aero/aircraft-/herrick.htm>

⁹⁵ Townson, George “The Herrick Convertaplane” *American Helicopter Museum & Education Center Newsletter* Vol. 4 No. 3 3rd Quarter 1997

⁹⁶ Conversation with the author August 2000.

⁹⁷ For photographs of the HV-2V in conversion from fixed-wing to gyroplane flight, see Haugen, Victor Lieutenant “Principles of Rotating Wing Aircraft” *Aeronautics* National Aeronautics Council Vol. II No. 7 October 16, 1940 p. 429; Brooks, Peter W. *Cierva Autogiros: The Development of Rotary-Wing Flight*. p. 25; Additionally the National Air and Space Museum of the Smithsonian

Institute film collections has a movie of the flying and mid-air conversion of the Herrick Convertiplane.

⁹⁸ See Connor, Roger “The Autogiros and Gyroplanes of the National Air and Space Museum” paper presented at the *From Autogiro to Gyroplane: The Past, Present and Future of an Aviation Industry Conference* at Hofstra University April 25 – 26, 2003; Boyne, Walter J. *The Aircraft Treasures of Silver Hill*. pp. 142 – 142 (Boyne called these aircraft the ‘Hapless Hybrids’.)

⁹⁹ Wood, Derek *Project Cancelled: British Aircraft That Never Flew* Indianapolis/New York: The Bobbs-Merrill Company Inc., 1975; Charnov, Bruce H. “The Fairey Rotodyne: An Idea Whose Time Has Come – Again – Part I” *Fly Gyro!* September/October 2001 pp. 4 – 7; “The Fairey Rotodyne: An Idea Whose Time Has Come – Again Part II” *Fly Gyro!* Nov/Dec 2001 pp. 4 – 7 “The Fairey Rotodyne: An Idea Whose Time Has Come –Again Part III” *Fly Gyro!* March/April 2002 pp. 4 – 8; Harrison, Jean-Pierre “Fairey Rotodyne” *Air Classics* Vol. 22, No. 44 April 1996 pp. 44 – 47, 60-62, 64 – 66, 79 – 80; Gibbings, David “The Fairey Rotodyne: Technology Before Its Time? *Cierva Memorial Lecture*. London, England: The Royal Aeronautical Society October 7, 2003; “The Fairey Rotodyne: Too Much, Too Soon” Paper presented at the *From Autogiro to Gyroplane: The Past, Present and Future of an Aviation Industry Conference* at Hofstra University April 25 – 26, 2003, printed in Charnov, Bruce H. and David Klein (eds.) *FROM AUTOGIRO TO GYROPLANE CONFERENCE PROCEEDINGS*, NY: Hofstra University 2004; “Rotodyne, the Airliner Whose Hour Came Too Soon.” *Proceedings: Society of Flight Engineers 26th Annual Symposium* Berlin June 1995; Hislop George S. “The Rotodyne Reviewed” *Flight*. Vol. 74 No. 2599 November 14, 1958 pp. 758 -759 ; *The Fairey Rotodyne*. London, England: The Helicopter Association of Great Britain and The Royal Aeronautical Society (paper presented on November 7, 1958); “Fairey Story: The Sad Saga of the Fairey Rotodyne” *WINGSPAN International*. Issue No. 8 September/October 2001 pp. 60 – 64; Lambermont, Paul M., and Anthony Pirie *Helicopters and Autogyros of the World*. pp. 115 – 117; Trenter, S. C. *The History, Operation and Application of the Autogyro*.

(Unpublished Final Year Project – The University of Birmingham, School of Manufacturing and Mechanical Engineering) 1997 p. 35; “The Fairey Rotodyne” *Air Pictorial*. October 1956; “The Fairey Rotodyne” *Air Pictorial*. December 1957 (cover); Taylor, John W. R. “The Fairey Rotodyne” *Meccano Magazine*. Vol. XLIII No. 7 July 1958 pp. 311 – 313, 354

¹⁰⁰ Taylor, John W. R. *VTOL Aircraft and Helicopters*. London: Ian Allan 1967; Garden City, New York: Doubleday, 1968 p. 39 (Note – also called “Vintokryl”); Lambermont, Paul M., and Anthony Pirie. *Helicopters and Autogyros of the World*. p. 412

¹⁰¹ While this may be what Herrick (1873 – 1955) is remembered for, it should be noted that he had graduated from Princeton University (A.B. 1895) and received an L.L.B. from the New York Law School in 1897, going on to serve in the Army Air Service during the 1918 – 1919 time frame, attaining the rank of Captain.

¹⁰² Platt, Haviland H. “The Development of the Helicopter: Past, Present and Future” *Proceedings of Rotating Wing Aircraft Meeting . . . October 28 and 29, 1938*. Philadelphia : Institute of Aeronautical Sciences 1938 Sponsored by the Philadelphia Section, Institute of the Aeronautical Sciences pp. 22 – 28

¹⁰³ See e.g., http://www.helis.com/pioneers/f_plp.php

¹⁰⁴ For a discussion of the Bartha/ Madzsar patents (English and German), see Liberatore, E[ugene] K. *Helicopters Before Helicopters*. Malabar, Florida: Krieger Publishing Company, 1998 p. 95

¹⁰⁵ Patent listed on Simine’s U.S. Aviation Patent Database (<http://invention.psychology.msstate.edu/patents/index.html>) and available at <http://patimg2.uspto.gov/piw?docid=US000922756&PageNum=2&IDKey=6521C17988D7&HomeUrl=http://patft.uspto.gov/netacgi/nph-Parser?Sect1=PTO1%2526Sect2>

¹⁰⁶ See also Hafner, Raoul “A Reply to Dr. J.A.J. Bennett” *Flight* November 1937; “reprinted in

Lovegrove, Peter *Gyroplane Miscellanea* Volume 3
England: The British Rotorcraft Association March
2003 pp. 170 – 179 in which Hafner points out the
previous English patents of Bartha and Madzsar

¹⁰⁷ See Connor, Roger [Douglas] “50th Anniversary
Perspectives on the American Helicopter Industry”
Vertiflite. Vol. 51 No. 1 January 2006 pp. 22 –
42: 28 “Ironically the LePage proposal won out
over Sikorsky’s design on the basis of its resem-
blance to the apparently proven German config-
uration . . . The twin lateral configuration had inher-
ent handling difficulties that the Germans had
hidden well . . . “

¹⁰⁸ For a sample of Knight’s published papers, see
Johnson, Wayne *Helicopter Theory*. Mineola, NY:
Dover Publications, 1980 p. 1022

¹⁰⁹ Otherwise unidentified – there is no reason to
suspect that this was Cierva test pilot R.A.C.
“Reggie” Brie.

¹¹⁰ “The Gyroplane” *Proceedings of Rotating Wing
Aircraft Meeting . . . October 28 and 29, 1938*.
Philadelphia : Institute of Aeronautical Sciences
1938 Sponsored by the Philadelphia Section,
Institute of the Aeronautical Sciences pp. 28 - 35

¹¹¹ As summarized *supra* – see footnotes 24 – 28
and accompanying text.

¹¹² See Trimble, William F. *High Frontier: A
History of Aeronautics in Pennsylvania*. University
of Pittsburgh Press 1982 pp. 180

¹¹³ See Hovgard, Paul “Safety – With Perform-
ance” *Aviation Engineering Magazine*. September
1931 p. 12

¹¹⁴ See e.g. Daland, Elliot “Wilford Gyroplane”
Aviation. January 1941 p. 42

¹¹⁵ On Loening, see Yenne, Bill *Legends of Flight
(forward by Frank Borman)*. Lincolnwood, Illinois:
Publications International, 1999 p. 208; Longyard,
William H. *Who’s Who in Aviation History*.
Shrewsbury, England: Airlife Publishing Ltd., 1994
p. 118

¹¹⁶ Johnson, Wayne *Helicopter Theory*. See the
extensive references to the research literature on
compound helicopter design cited on p. 341

¹¹⁷ For a description and photographs of the
brothers Kellett, see “Autogiro in 1936.” *Fortune*
Vol. XIII No. 3 March 1936 88 – 93, 130 – 131,
134, 137: 130

¹¹⁸ See Fn. 74 *supra* for background on
conversation between Kellett and Gregory.

¹¹⁹ Gregory, H[ollingsworth] F[ranklin] “Army
Experiences With Rotating Wing Aircraft”
Proceedings of Rotating Wing Aircraft Meeting.
The Franklin Institute. Philadelphia, PA, Oct. 28 –
29, 1938 pp. 36 - 43

¹²⁰ Gregory, Hollingsworth Franklin. *Anything A
Horse Can Do: The Story of the Helicopter*. pp. 86
– 87

¹²¹ See Glines, C. V. “The ¹²¹ Guggenheims:
Aviation Visionaries” *Aviation History*. November
1996 pp. 26 – 32, 70 71, 76

¹²² As cited in Smith, Frank Kingston. *Legacy of
Wings: The Story of Harold F. Pitcairn* p. 252

¹²³ Gregory, H[ollingsworth] F[ranklin] “Army
Experiences With Rotating Wing Aircraft”
Proceedings of Rotating Wing Aircraft Meeting. p.
36

¹²⁴ See <http://www.usafhpa.org/histpg01.htm>

¹²⁵ Liberatore, E[ugene] K. *Helicopters Before
Helicopters*. pp. 97 – 99 (noting that “the experi-
menters also may be the first to use the term *rota-
ting wing* for a helicopter rotor.”)

¹²⁶ While Gregory asserts that the Army had experi-
mented with McWorter’s 1/4 scale model, Libera-
tore cites this *Autoplane* in his “Other Projects” Ap-
pendix, stating that “[t]he following list of activities
are not covered in the narratives, mainly because
little information is available on them to warrant
narrative treatment.” Liberatore, E[ugene] K.
Helicopters Before Helicopters. pp. 171 – 174

¹²⁷ See e.g., Young, Warren R. *The Helicopters*.
pp. 42 - 49

¹²⁸ Holley, I. B. Jr. *Rotary-Wing Aircraft in the Army Air Forces: A Study in Research and Development Policies*. Industrial College of the Armed Forces, Washington, DC, 1946 p. 218

¹²⁹ See e.g., the Pitcairn advertisements in Young, Warren R. *The Helicopters*. pp. 62 – 63

¹³⁰



¹³¹ At the celebration of Raymond Pitcairn's 75th birthday on April 23, 1960, Harold F. Pitcairn presided as master-of-ceremonies at a party attended by 40 guests. He would read telegraphs of congratulations from former President Eisenhower, civic leaders, and officials from around the world. Later that night, after returning from the celebrations, the younger brother would be found dead at his desk, a bullet in his brain and a gun in his hand. Initially ruled a suicide and, after some pressure and non-cooperation from the family, then found to be acid-ental. See Smith, Frank Kingston. *Legacy of Wings: The Story of Harold F. Pitcairn* p. 334; see also Charnov, Bruce H. *From Autogiro to Gyroplane: The Amazing Survival of an Aviation Technology*. p. 233

¹³² For a detailed history of the development of the aeronautical industry and innovation in Pennsylvania, see Trim-ble, William F. *High Frontier: A History of Aeronautics in Pennsylvania*.

¹³³ For a description of Pitcairn's social status, one that should be read with caution, see O'Brien, Kathryn E. *The Great and the Gracious on*

Millionaires' Row. Utica, New York: North Country Books, Inc., 1978

¹³⁴ He would summarize some of his ideas in Prewitt, Richard H. "Possibilities of the Jump Take-Off Autogiro" *Journal of Aeronautical Sciences*. Vol. 6 No. 1 November 1938

¹³⁵ For a photograph of the first graduating class of the Army Air Corps Autogiro School, see Townson, George. *Autogiro: The Story of 'the Windmill Plane'* p. 117 (note that the attribution of the rank of Colonel to H. Franklin Gregory is incorrect in the photo's caption)

¹³⁶ Dorsey, Frank J. G. "Government Use and Development" *Proceedings of Rotating Wing Aircraft Meeting*, The Franklin Institute. Philadelphia, PA, Oct. 28 – 29, 1938 pp. 44 – 53

¹³⁷ For a montage of Pitcairn/Kellett advertisements, see Townson, George. *Autogiro: The Story of 'the Windmill Plane'*. pp. 151- 155

¹³⁸ Earhart, Amelia "Your Next Garage May House An Autogiro." *Hearst's International combined with Cosmopolitan*. Vol. XCI No. 2 August 1931 pp. 58 – 59, 160 – 161

¹³⁹ Conversation with the author.

¹⁴⁰ But see "Autogiro in 1936." *Fortune* Vol. XIII No. 3 March 1936 88 – 93, 130 – 131, 134, 137:130 where it is claimed that the actual total was then \$4,500,000. It was also claimed there that the Kellett Brothers had invested \$500,000.

¹⁴¹ Peter Brooks, in his excellent book CIERVA's AUTOGIROS (pp. 165, 192, 268) , notes only five fatal accidents: Lioré-et-Olivier pilot Pierre Martin while flying a C.L. 10 on December 19, 1932; Flying Officer L. W. Oliver who failed to recover from a high speed dive in a Rota C.30A at Old Sarum on January 21, 1935; passenger Robert Swenson who died in a crash of a PA-18 at Willow Grove, Pennsylvania in August 1935; a Captain Barbotin who was rumored to have perished just before WWII in Northern France when his LeO C.30 lost a rotor blade; and the death of French pilot Vautier in an unsuccessful landing in a C.30A at Rouen on May 29, 1938. Additionally, Brooks (Brooks p. 168) states that it was known that Rus-

sian pilot I. Kozyrev crashed in a TsAGI gyroplane (not an Autogiro as it was not a Cierva-licensed machine) A-12 on May 23, 1937. John M. “Johnny” Miller provides the only detailed account of the worst Autogiro accident in which Carl (mistakenly remembered as Charlie) Otto and *two passengers* died on September 5, 1933– the worst Autogiro accident in history. It is a cautionary tale that deserves to be remembered. Here is how Miller described it sixty-three years later, stating that after the 1933 International Air Races at Chicago:

“Vincent Bendix invited the participants to gather at his estate at South Bend for a dinner and party, offering free fuel to those who flew in. . . . As I took off and turned south to go around the south end of the lake [Michigan] I saw Charlie [Otto] take off in his PCA-2 and head straight across the lake. The wind was practically calm there. . . . Due to the unexpected headwind I did not have enough fuel to make it to South Bend, so landed at the Department of Commerce emergency field at McCool, Ill where I knew that I could get fuel out of a barrel in the little airway beacon shed. It was a very hot and humid day and we sweated at the job of getting about 15 gallons out of the barrel with the help of the man in charge of the field. Then we continued on to South Bend. . . . On arrival over the field Charlie’s PCA-2 was not there. Flying across the lake with minimum fuel he could not be aware of his low ground speed. He ran out of fuel and went down in the lake. He and his two passengers were lost. One passenger was a well-known free-fall parachutist, Spud Manning, whom I had taken up over the air show to 15,000 ft several times and knew well. (Free-fall jumps were new and spectacular at the time and Spud Manning was the pioneer of that sport).”

Miller, John M. “UFO Recollections – The Death of Charlie Otto” *American Helicopter Museum & Education Center Newsletter* Vol. 8 No. 1 Spring 1996

¹⁴² For a description of Autogiro accidents, see “Autogiros of 1931 - 1932” *Fortune* March 1932 pp. 48 – 52

¹⁴³ Dorsey did not literally mean that Pitcairn and Kellett sold Cierva Autogiros, and he surely was aware that each manufacturer had developed uniquely American designs. Rather, it seems logical that he intends “Cierva-licensed” autogiros (which, because of their derivation, should be correctly denoted Autogiros)

¹⁴⁴ Smith, Frank Kingston. *Legacy of Wings: The Story of Harold F. Pitcairn*. p. 240; Brooks, Peter W. *Cierva Autogiros: The Development of Rotary-Wing Flight*. p. 152

¹⁴⁵ Dorsey would go on to state: Without any direct knowledge, I am told the Haines-Act autogiro mail line will be set up in the near future. The post office department is said to have its plans completed and shortly will call for bids for the service, probably terminating in either Philadelphia or Chicago.

¹⁴⁶ On that Autogiro airmail route, see Charnov, Bruce H. “John M. “Johnny” Miller – Tales of an Autogiro Pioneer” *International AUTOGYRO 1/4ly*. Issue 22 2005 pp. 14 – 17; Miller, John M. “Autogiro Rooftop Air Mail Operations and Flight Testing” *Skyways: The Journal of the Airplane 1920 – 1940*. No. 71 July 2004 pp. 2 – 7; “The First Scheduled Rooftop Flying Operation and a Few Other Firsts” *Rotorcraft*. Vol. 41 No. 8 December-January 2004 pp. 27 – 30; “The First Scheduled Rooftop Flying Operation in Aviation (Autogiro Air Mail Service at Philadelphia, 1939-40)” *Rotorcraft*. Vol. 30 No. 6 September 1992 pp. 24 – 33; for a digitized copy of Miller’s film of the Kellett KD-1B Autogiro landings on the Philadelphia Post Office roof, see Charnov, Bruce H. and David Klein (eds.) *FROM AUTOGIRO TO GYRO PLANE CONFERENCE PROCEEDINGS*. Hempstead, NY: Hofstra University 2004

¹⁴⁷ Biological Survey and Coast and Geodetic Survey departments

¹⁴⁸ The May 31, 1939 meeting laid the foundation for American military rotary-wing development and insured that the helicopter would eventually join America’s arsenal. Those attending were: J.P. Godwin, Department of Agriculture; Frederick C. Lincoln, U.S. Biological Survey; Charles M. Kieobee, Division of Air Military Service; Captain L. T.

Chalker, U.S. Coast Guard; John Easton, Civil Aeronautics Authority; Lieutenant Commander C. L. Helber, Bureau of Aeronautics; Roy Knabenshue, Department of the Interior; C. S. Helds and C. W. Crowley, Jr., of the NACA; Major W. C. Crittenberger, Calvary; Major R. W. Beasley, Field Artillery; Lieutenant Colonel Dale D. Miniman, Coast Artillery; and Lieutenant Colonel E. W. Fales of the Infantry. Gregory, Hollingsworth Franklin. *Anything A Horse Can Do: The Story of the Helicopter* p. 91

¹⁴⁹ Box 20, File 8: Early Aviators Special Collection & Archives of the Wright State University Libraries

¹⁵⁰ For an exception, see Hill, Norman (Flying Officer) "Wingless Combat" *Royal Air Force Flying Review*. Vol. XVIII No. 4 January 1963 pp. 24 – 25, 57 with an account of how a Cierva C.30A survived an attack from two German FW 190 fighter planes.

¹⁵¹ See Gunston, Bill *The Osprey Encyclopedia of Russian Aircraft*. Oxford, England: Osprey Publishing Limited, 1995, 2000 and *Aircraft of the Soviet Union*. London: Osprey, 1983; Andersson, Lennart *Soviet Aircraft and Aviation 1917 – 1941*. Annapolis, MD: Naval Institute Press 1994 (first published London, England: Putnam Aeronautical Books); Everett-Heath, John *Soviet Helicopters: Design, Development and Tactics* London: Jane's Publication Company 1983; Bratukhin, A. G. (ed) *Russian Aircraft*. Moscow: Mashinostroenie 1995 (in Russian but with English translation). Also see Charnov, Bruce H. "Autogyros in the Soviet Union During WWII" *Homebuilt Rotorcraft*. Vol. 15 No. 11 November 2002 pp. 8 – 10, and "Kamov & Skrzhinsky – Russian Gyroplane Pioneers" *International AUTOGYRO 1/4ly*. Issue 10 October 2001 pp. 18 – 23; Eyermann, Karl-Heinz *Die Luftfahrt der UdSSR 1917 – 1977* Berlin: transpress VEB Verlag für Verkehrswesen 1977

¹⁵² See e.g., Riviere, Pierre and Gerry Beauchamp, "Autogyros At War" *Air Classics Quarterly Review*. Vol. 3 No. 4 Winter 1976 pp. 92 – 97; Moulin, Jacques *Les autogires LeO C.30 et C.301*. Outreau, France: Lela Presse 2003 a chapter of which has been translated and published as Ledet, Michel "The Cierva C.30A with the Small Air Forces" *Small Air Observer*. Vol. 27 No. 4 (108) April 2004 pp. 115 – 122; Charnov, Bruce H. "The Autogiro Goes to War in France" *Home-*

built Rotorcraft. Vol. 16 No. 2 February 2003 pp. 5 – 7

¹⁵³ Everett-Heath, John *British Military Helicopters*. as well as in March, Daniel J. (ed.) *British Warplanes of World War II: Combat Aircraft of the RAF and Fleet Air Arm 1939 – 1945*. New York: Barnes & Noble Books 1998, Gunston, Bill *History of Military Aviation*. London: Hamlyn (Octopus Publishing Group Limited) 2000, the same author's earlier volume *Helicopters at War*. London, England: Hamlyn 1977, in Gunston, Bill and Mike Spick *Modern Fighting Helicopters*. New York: Crescent Books 1988; London: Tiger Books 1991, and Rees, Elfan ap "The Helicopter's First War" in Jarrett, Philip (ed) *Aircraft of the Second World War: The Development of the Warplane 1939 – 45*. London, England: Putnam Books 1997 pp. 177 – 191; Barker, Ralph *The RAF At War*. Alexandria, VA: Time-Life Books 1981; see "The Hafner Rotachute" *Aeroplane Monthly*. Vol. 19 No. 8 Issue 220 August 1991 pp. 470 – 476; Bensen, Igor "Rotachute, Rotary Wing Glider-Kite." General Electric Co., Report No. 33200. Schenectady, NY: 1946; Hollmann, Martin "The Rotachute" *Gyroplane World*. Issue 7 April 1977 1 – 3; "The "Rotachute" and "Rotabuggy"" *Popular Rotorcraft Flying*. Vol. 19 No. 1 February 1981 pp. 14 – 15, 20 – 21; "The Hafner Rotachute." *Fly Gyro!* No. 3 February 2001 pp. 18 – 19; "Design Classroom." *Collected Works of Design Classroom*. California: Popular Rotorcraft Association 1974 p. 11; Brooks, Peter W. *Cierva Autogiros: The Development of Rotary-Wing Flight*. pp. 286 – 287; Bartlett, Ron "Gyroplanes – The Early Years" *International Autogyro 1/4ly*. Issue 5 p. 13 (author's photograph of the Rotachute exhibited at the Army Air Corps Museum at Middle Wallop, England)

¹⁵⁴ See Nicholls, R. A. "Annals of the Autogyro" in Horseman, Martin (ed) *Aircraft Illustrated Annual 1982*. London: Ian Allan Ltd 1981 pp. 18 – 36 which contains *inter alia* an account of the WWII exploits of Swedish Autogiro pilot Rolf von Bahr flying a Cierva C. 30A Autogiro; see also Molin, Karl-Gustaf, Sten Luthander and Rolf von Bahr *Autogiron*. Stockholm: Bonnier 1943 (Swedish)

¹⁵⁵ On Japan, see Francillon, R. J. *Japanese Aircraft of the Pacific War*. London: Putnam, 1970; Tamate, Eiji *Imperial Japanese Army Ka Go Autogiro*. (Japanese) Tokyo, Japan: Kojin Sha,

2002; Mondey, David (ed.). *The Concise Guide to Axis Aircraft of World War II*. London: Chancellor Press 1984, 1996

¹⁵⁶ Wood, Tony and Bill Gunston *Hitler's Luftwaffe*. New York, NY: Crescent Books, 1978; Smith J. R. and Antony L. Kay, *German Aircraft of the Second World War* London, England: Putnam, 1972; Goebel, Greg "The Invention of the Helicopter" *Rotorcraft*. Vol. 42 No. 7 October - November 2004 pp. 11 – 25; "Flying A Kite: The Focke-Achgelis Fa-330 Rotary Wing Kite." *Rotor Gazette International* No. 2 Vol. 1 July – August 1992 pp. 1 – 2, 4; "Focke Achgelis FA-330 Bachstelze (Wag-tail)." *Fly Gyro!* No. 3 February 2001 pp. 8 – 9; Focke, Heinrich K. J. "German Thinking on Rotary-Wing Development: (5th Cierva Memorial Lecture)" *Journal of the Royal Aeronautical Society*. Vol. 69 May 1965 pp. 293-305; Gallacher, Ian "Germany's Wartime Autogyro Kite" *WING-SPAN*. August 1991 pp. 37 – 38; "Germany's Wartime Autogyro Kite" *Air Pictorial*. August 1991 pp. 37 – 38; Liptrot, R. N. "Rotating Wing Activities in German During the Period 1939 – 1945." B.I.O.S. Overall Report 8, London: 1948; Ford, Brian *German Secret Weapons: Blueprint for Mars*. New York: Ballentine Books, 1969; *German Submarine Rotary Wing Kite*. Combined Intelligence Objectives Sub-Committee London (CIOS) (Reported by Kelley, Bartram and Hugh J. Mulvey), England: 1945; Philpott, Bryan *The Encyclopedia of German Military Aircraft*. New York: Park South Books, 1981; Smith J. R. and Antony L. Kay, *German Aircraft of the Second World War* London, England: Putnam, 1972; Coates, Steve (with Jean-Christophe Carbonel) *Helicopters of the Third Reich*. Hersham, Surrey, England: Classic Publications 2002

¹⁵⁷ Galloway, A. G. "Agricultural Uses" *Proceedings of Rotating Wing Aircraft Meeting*, The Franklin Institute. Philadelphia, PA, Oct. 28 – 29, 1938 pp. 53 – 57

¹⁵⁸ See e.g., MacKay, Hal "Bug Fighters" *Popular Aviation*. Vol. XXIV June 1939 pp. 48 – 50, 82

¹⁵⁹ Kellett would unsuccessfully attempt to revive the KD-1 for crop spraying and other agricultural uses circa 1959 – 60. See e.g. Ray, James G. "Is the Autogyro Making a Comeback?" *Flying*. Vol. 66 No. 1 January 1960 pp. 34- 35, 91 – 92; Levy,

Howard "Kellett Gyration" *Aeroplane*. Part 3 Vol. 24 No. 1 Issue 273 January 1996 pp. 32 – 34;34; Townson, George. *Autogyro: The Story of 'the Windmill Plane'*. p. 138; "Rotary-wing Aircraft" *Flying*. Vol. 67 No. 4 October 1960 pp. 24 – 26, 100 – 101; see also:

¹⁶⁰ See Townson, George "Autogyro Crop Dusters." *American Helicopter Museum & Education Center Newsletter* Vol. 3 No. 1 Spring 1996

¹⁶¹ Miller, John M. "Autogyro Piloting Technique" *Proceedings of Rotating Wing Aircraft Meeting*, The Franklin Institute. Philadelphia, PA, Oct. 28 – 29, 1938 pp. 57 - 63

¹⁶² Regarding Miller, see e.g., Abbott, Paul Bergen "Flying the 'Windmill Plane' With Johnny Miller" *Popular Rotorcraft Flying*. Vol. 24 No. 6 December 1986 pp. 18 – 20; "Captain Johnny Miller" *Rotorcraft*. Vol. 40 No. 9 December 2002 – January 2003 pp. 8 – 9; Charnov, Bruce H. "John M. "Johnny" Miller – Tales of an Autogyro Pioneer" *International AUTOGYRO 1/4ly*. Issue 22 2005 pp. 14 – 17; Walker, Bud "People & Planes: Captain John Miller" *Aviation History*. Vol. 7 No. 2 November 1996 pp. 14, 16, 18

¹⁶³ Miller, John M. "The Missing Link in Aviation" *Popular Mechanics Magazine*. Vol. 70 No. 3 September 1938 pp. 346 – 351. 134A- 135A (reprinted *Homebuilt Rotorcraft*. Vol. 5 No. 7 July 1992 pp. 4 – 6; 12 – 14; reprinted *Homebuilt Rotorcraft*. Vol. 9 No. 1 January 1996 pp. 4 – 6; *Homebuilt Rotorcraft*. Vol. 15 No. 11 November 2002 pp. 14 – 16)

¹⁶⁴ Miller, John M. "Civil Uses of the Autogyro." *Aeronautics* National Aeronautics Council Vol. II No. 10 November 6, 1940 pp. 611 – 624

¹⁶⁵ Miller was still flying his Bonanza at 100 years old, although the FAA now required him to have a co-pilot. The co-pilot informed this author that Miller would let him sit in the plane, but not touch the controls during flight.

¹⁶⁶ For a more detailed discussion of Autogyro piloting techniques, see Brie, R.A.C. *The Autogyro and How to Fly It*. London: Sir Isaac Pitman & Sons, 1933 2d. ed. 1935

¹⁶⁷ For Lou Levy, see "Autogiro in 1936." *Fortune* Vol. XIII No. 3 March 1936 88 – 93, 130 – 131, 134, 137 p. 89; Miller, John M. "Test Flying for Kellett Autogiro Corporation" *Rotorcraft*. Vol. 30 No. 7 October – November 1992 pp. 22 – 28 p. 22; "The First Scheduled Rooftop Flying Operation in Aviation (Autogiro Air Mail Service at Philadelphia, 1939-40)" *Rotorcraft*. Vol. 30 No. 6 September 1992 pp. 24 – 33 p. 24; Gregory, Hollingsworth Franklin. *Anything A Horse Can Do: The Story of the Helicopter*. p. 55 ("... and Lou Levy (later his name was changed to Leavitt), test pilot for Kellett.")

¹⁶⁸ Ray, James G. "Commercial Uses of Rotary Wing Aircraft" *Proceedings of Rotating Wing Aircraft Meeting*. The Franklin Institute. Philadelphia, PA, Oct. 28 – 29, 1938 pp. 63 – 69

¹⁶⁹ A true statement. While the first Autogiro flown in America was the imported Cierva C.8W, the first Autogiro actually built in America was the Pitcairn-Cierva Autogiro Company PCA-1 in 1929.

¹⁷⁰ For a contemporary account of the delivery of the "roadable" Autogiro, see "Roadable Autogiro" *AVIATION*. Vol. 35 No. 11 November 1936 pp. 33 – 34

¹⁷¹ On the AC-35, see Swinford, George R. "AC – 35" *Popular Rotorcraft Flying* Vol. 7 No. 1 January – February 1969 pp. 20 – 22; reprinted in Lovegrove, Peter *Gyroplane Miscellanea* Volume 5 England: The British Rotorcraft Association 2004 pp. 82 – 88; Hollmann, Martin "The Pitcairn AC-35" *Gyroplane World*. Issue 27 December 1978 pp. 3 – 4; *Aircraft of the National Air and Space Museum* 4th Ed. Washington, D.C.: Smithsonian Institution Press 1991 (see "Pitcairn AC-35; For pictures of the various configurations of the AC-35, see Smith, Frank Kingston. *Legacy of Wings: The Story of Harold F. Pitcairn* pp. 243 – 245; Townson, George. *Autogiro: The Story of 'the Windmill Plane'*. pp. 59 – 61; Charnov, Bruce H. *From Autogiro to Gyroplane: The Amazing Survival of an Aviation Technology*. Westport, CT: Praeger Publishers 2003 pp. 112, 124 – 127, 137

¹⁷² For photographs of the AC-35 being driven through the streets of Washington, D.C., see Boyne, Walter J. *The Aircraft Treasures of Silver Hill*. Pp. 137 - 139

¹⁷³ "THE FAIREY ROTODYNE – Nearly The Answer." *West Coast Aviator* September/October 1995 pp. 35 – 37

¹⁷⁴ Cited by Brooks as a 4-5 seater. Brooks, Peter W. *Cierva Autogiros: The Development of Rotary-Wing Flight*. pp. 149 – 152

¹⁷⁵ Noorduyn, Robert B. C. "Pitcairn PA-19 Cabin Autogiro." *Aero Digest* Vol. 22, No. 2 February 1933 pp. 48 – 50 reprinted in *Skyways: The Journal of the Airplane 1920 – 1940*. No. 72 October 2004 pp. 56 – 59; *Pitcairn Cabin Autogiro*. (brochure) Willow Grove, PA: Autogiro Company of America 1937

¹⁷⁶ With regard to Hafner, see the definitive paper Leishman, J. Gordon "The Gyroplanes, Helicopters and Convertiplanes of Raoul Hafner" Paper presented at the American Helicopter Society *Forum 61*. Dallas, TX June 1 – 3, 2005 reprinted in *Proceedings of the American Helicopter Society Forum 61*

¹⁷⁷ Hafner, Raoul "The Hafner Gyroplane" *Proceedings of Rotating Wing Aircraft Meeting*. The Franklin Institute Philadelphia, PA, Oct. 28 – 29, 1938 pp. 69 – 78

¹⁷⁸ Hafner, Raoul "The Hafner Gyroplane" *Journal of the Royal Aeronautical Society*. Vol. 42 1938 pp. 109 – 158 (including discussion)

¹⁷⁹ Leishman, J. Gordon "The Gyroplanes, Helicopters and Convertiplanes of Raoul Hafner" pp. 1, 4

¹⁸⁰ For a description and discussion of Hafner's AR.IV, AR.V, P.D.6 Helicopter and PD.7 "relatively advanced looking helicopter designs", see Leishman, J. Gordon "The Gyroplanes, Helicopters and Converti-planes of Raoul Hafner" pp. 4 - 5

¹⁸¹ Lewis, Dr. George W. "Introductory Remarks for Session on Rotary Wing Research Programs" *Proceedings of Rotating Wing Aircraft Meeting*, The Franklin Institute. Philadelphia, PA, Oct. 28 – 29, 1938 pp. 84 - 85

¹⁸² Klemin, Alexander and Everett B. Schaefer "A Note on Rotary Aircraft Research" *Proceedings of Rotating Wing Aircraft Meeting*, The Franklin Insti-

tute. Philadelphia, PA, Oct. 28 – 29, 1938 pp. 85 – 92

¹⁸³ Knight, Professor Montgomery “Helicopter Research Program of the Georgia School of Technology” *Proceedings of Rotating Wing Aircraft Meeting*, The Franklin Institute. Philadelphia, PA, Oct. 28 – 29, 1938 pp. 92 – 99

¹⁸⁴ Bailey, F. J. Jr. “The Rotating-Wing Research of the National Advisory Committee for Aeronautics” *Proceedings of Rotating Wing Aircraft Meeting*, The Franklin Institute. Philadelphia, PA, Oct. 28 – 29, 1938 pp. 99 – 103

¹⁸⁵ Johnson, Wayne *Helicopter Theory*. p. 965

¹⁸⁶ Connor, Roger [Douglas] “50th Anniversary Perspectives on the American Helicopter Industry” *Vertiflite*. p. 27

¹⁸⁷ Citing Roland, A. *Model Research: The National Advisory Committee for Aeronautics, 1915 – 1958*, Vol. 1, NASA Scientific and Technical Information Branch, Washington, DC. 1985, p. 131

¹⁸⁸ Hafner, Raoul “The Hafner Gyroplane and Helicopter” *Proceedings of Rotating Wing Aircraft Meeting*, The Franklin Institute. Philadelphia, PA, Oct. 28 – 29, 1938 pp. 109 – 117

¹⁸⁹ Fay, John. *The Helicopter*. Fig. 152 pp. 140 – 141

¹⁹⁰ Leishman, J. Gordon “The Gyroplanes, Helicopters and Convertiplanes of Raoul Hafner” p. 1

¹⁹¹ As Leishman goes on to note, “Hafner was also to introduce the concept of a collective pitch lever held in the pilot’s left hand and a cyclic lever in the pilot’s right hand, which was to become the standard for modern helicopters.”

¹⁹² A question that might well be asked of the military’s V-22 ‘tiltrotor’.

¹⁹³ “An Investigation into the Problem of the Rotor Torque of a Helicopter” *Proceedings of Rotating Wing Aircraft Meeting*, The Franklin Institute. Philadelphia, PA, Oct. 28 – 29, 1938pp. 133 – 155

¹⁹⁴ And, as illustrated by Leishman in his 2005 paper on Hafner, he made “meticulous calculations of the flow below the rotor [which] showed the effectiveness of using fixed aerodynamic surfaces to counter rotor torque reaction and to give directional control.”

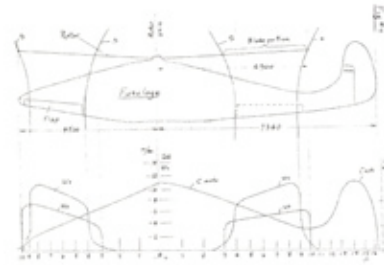
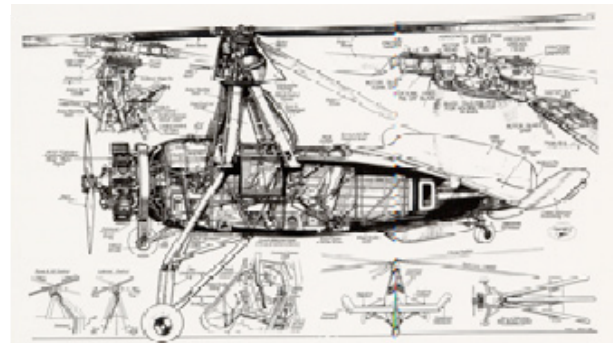

Figure 11: Hafner’s meticulous calculations of the flow below the rotor showed the effectiveness of using fixed aerodynamic surfaces to counter rotor torque reaction and to give directional control.

¹⁹⁵ Leishman, J. Gordon “The Gyroplanes, Helicopters and Convertiplanes of Raoul Hafner”

¹⁹⁶ Hovgard, Paul E. “Future Types of Gyroplanes” *Proceedings of Rotating Wing Aircraft Meeting*, The Franklin Institute. Philadelphia, PA, Oct. 28 – 29, 1938 pp. 118 – 124

¹⁹⁷



¹⁹⁸ See e.g., Glauert, H. “A General Theory of the Autogyro” British Aeronautical Research Council R&M 1111, Nov. 1926 reprinted in *Journal of Royal Aeronautical Society*. Vol. 31 No. 198 June 1927 pp. 505 – 506 ; “A General Theory of the Autogyro” Air Ministry Aeronautical Research Committee Report and Memoranda Number 1111 London: November 1926; Glauert, H. and C. N. H. Lock “A Summary of the Experimental and Theoretical Investigations of the Characteristics of an Autogyro” British Aeronautical Research Council R&M 1162 April 1928; *but also see* Cierva y Codorniu, Juan de la Letter to RAeS with comments on Glauert, H. “A General Theory of the Autogyro”

Journal of Royal Aeronautical Society. Vol. 31 No. 198 1927 pp. 505 – 506

¹⁹⁹ See e.g., Glauert, H. "On the Horizontal Flight of a Helicopter" British Aeronautical Research Council R&M 1157, March 1928; "On the Vertical Ascent of a Helicopter" British Aeronautical Research Council R&M 1132, Nov. 1927; see also Glauert, H. *The Elements of Aerofoil and Airscrew Theory.* Cambridge, England: Press Syndicate of the University of Cambridge 1926, 1947 (reprinted 1930, 1937, 1942) (Second edition 1947, reprinted 1948, 1959, reissued 1983 in Cambridge Science Classics Series, reprinted 1986, 1993)

²⁰⁰ See e.g. "The Wilford Gyroplane" *Aero Digest.* Vol. 25 No. 2 February 1932 pp. 56 – 57; Daland, Elliot "Wilford Gyroplane" *Aviation.* January 1936 p. 42; Brooks, Peter W. *Cierva Autogiros: The Development of Rotary-Wing Flight.* p. 23; Lambermont, Paul M., and Anthony Pirie. *Helicopters and Autogyros of the World.* p. 406

²⁰¹ On David Kay, see Lambermont, Paul M., and Anthony Pirie. *Helicopters and Autogyros of the World.* p. 123; Ellis, Ken *British Home Built Aircraft Since 1920.* Liverpool, England: Merseyside Aviation Society Publication 1979 pp. 173 – 175; "Kay Gyroplane" *Flight.* December 27, 1934; "The Kay Gyroplane Type 331." *Aeroplane.* December 26, 1996 pp. 32 – 34; Ogden, Bob "Kay Gyroplane" *WINGSPAN.* August 1991 p. 37

²⁰² Hovgard is probably referring to Focke, H. "The Focke Helicopter" NACA TM 858, April 1938; see also Leishman, J. Gordon "A History of Helicopter Flight" 2000 at <http://www.enaе.umd.edu/AGRC/Aero/history.html>

²⁰³ "Helicopter or Autogiro?" *Flying Cadet.* Vol. 2 No. 2 February 1944 p. 46

²⁰⁴ Haymes, Dick *I'll Buy That Dream" 1946* featured originally in the 1945 RKO Picture *Sing Your Way Home* words by Herb Magidson, music by Allie Wrubel

²⁰⁵ LePage, W[yann] Laurence "The Helicopter in Europe" *Proceedings of Rotating Wing Aircraft Meeting,* The Franklin Institute. Philadelphia, PA, Oct. 28 – 29, 1938 pp. 124 – 130

²⁰⁶ On LePage, see "Personalities in the Helicopter Industry: Presenting Wynn Laurence LePage" *American Helicopter.* October 1947 pp. 19 , 27-28; Hendrickson, J. B[rian] Dr. W. Laurence LePage: Remembering A Forgotten Pioneer paper presented at the *From Autogiro to Gyro-plane: The Past, Present and Future of an Aviation Industry* Conference at Hofstra University April 25 – 26, 2003, reprinted in Charnov, Bruce H. and David Klein (eds.) *FROM AUTOGIRO TO GYROPLANE CONFERENCE PROCEEDINGS.* Hempstead, NY: Hofstra University 2004; "W. Laurence LePage, From XR-1 to Tilt-Rotor" Paper presented at the American Helicopter Society *Forum 61.* Dallas, TX June 1 – 3, 2005 reprinted in *Proceedings of the American Helicopter Society Forum 61*

²⁰⁷ Bréguet, Louis "The Gyroplane – Its Principles and Its Possibilities" National Advisory Committee for Aeronautics TM 816, January 1937

²⁰⁸ And, given the military alarm at the Fa-61 public performance, also made it easier for military intelligence to study the German helicopter.

²⁰⁹ On Friedrich von Boetticher, see Beck, Alfred M. *Hitler's Ambivalent Attache: Lt. Gen. Friedrich Von Boetticher In America, 1933-1941.* Dulles, VA: Potomac Books, Inc. 2005. The book description states that: Friedrich von Boetticher was Germany's only military attaché accredited to the United States between the world wars. As such, he was Germany's official military observer in the capital of the nation whose potential as an ally of those powers arrayed against Adolf Hitler in the 1930s might have given the dictator pause in any predatory plans he harbored against his neighbors. Though von Boetticher produced a rich and detailed commentary on military and political affairs in Washington in the eight years prior to the outbreak of war between Germany and the United States in 1941, he was nonetheless accused after the war of misjudging America's productive potential and misleading Hitler with overly optimistic reports. As Alfred M. Beck points out, what he actually told German authorities in Berlin is strikingly different from what his detractors later claimed. Von Boetticher "permits a glimpse into the sociology of a conservative officer caste at once assailed by the politics of a regime and the impossibilities imposed on it, its weaknesses in resisting its evils, and its

eventual failure to present an alternative to National Socialism's illusory attractions."

A loyal German, von Boetticher had strong ties to America. His mother was American-born, he spoke English fluently, and he was enamored of American military history. He was also anti-Semitic and believed that "Jewish wire-pullers" had undue influence over the U.S. government and its policies. His professional ties to U.S. Army officers in the War Department were so strong—supplying them, for example, with details on German air strength and operations during the Battle of Britain in 1940—that they survived until August 1941 and long after the German ambassador himself had been recalled. Torn between his duty to Germany (though the Nazi regime had attempted to harm his son) and his deep affection for America, von Boetticher stood among the broad middle range of German officials who were neither perpetrator nor victim.

²¹⁰ Munk, Dr. Max M. "High Speed With Safety" *Proceedings of Rotating Wing Aircraft Meeting*, The Franklin Institute. Philadelphia, PA, Oct. 28 – 29, 1938 pp. 130 - 132