



**34th Annual AHS International Student Design Competition**

# **24 Hour Hovering Machine Conceptual Design**

*Sponsored by Sikorsky A Lockheed Martin Company*



**UNIVERSITY OF  
MARYLAND**

Alfred Gessow Rotorcraft Center  
Department of Aerospace Engineering  
University of Maryland  
College Park, MD 20742



**Alfred Gessow Rotorcraft Center**  
Department of Aerospace Engineering  
University of Maryland  
College Park, MD 20740 U.S.A.

To the American Helicopter Society:

The members of the University of Maryland Graduate Student Design Team hereby grant AHS full permission to distribute the enclosed Executive Summary and Final Proposal for the 34<sup>th</sup> Annual Design Competition as they see fit.

Thank you,

The UMD Graduate Design Team

# Elysium Technology Demonstrator Innovations



**Twin Rotor Configuration**  
 Rotors operate in clean aerodynamic environment for best gross take off weight and fuel

**Semi-Articulated Hub**  
 Mechanically compact and virtually maintenance free durable composite hub



**Reliable Drive Train**  
 Reduced number of moving parts and mechanically simple design increases reliability while minimizing maintenance

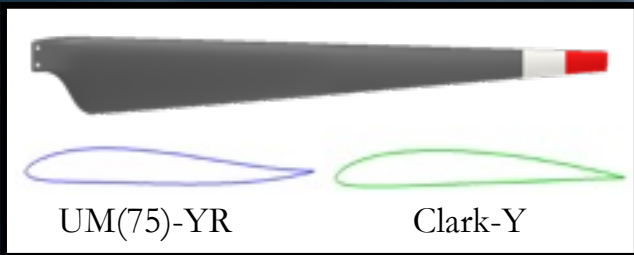



**Optimized Aerodynamics**  
 Original airfoil design and novel blade geometry produce unprecedented performance

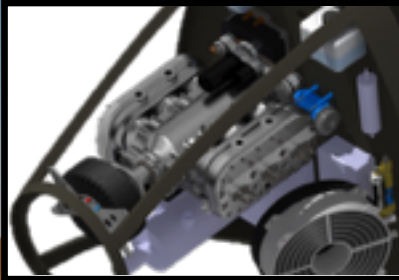

**Half-Cyclic Controls**  
 Light weight Fly-By-Wire architecture with fewer primary actuators

**Hybrid Power Plant**  
 Modular streamlined piston engine with 96% efficient electric generator allows for future technology



**Light Weight Structures**  
 Constructed from lightweight composites optimized elliptic arms maintain stiffness and strength requirements

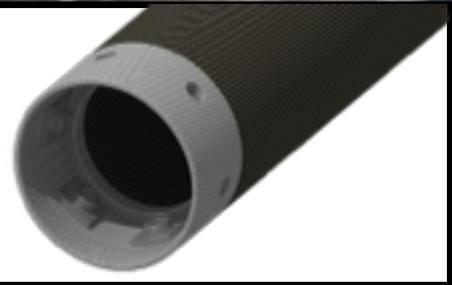

Key Parameters	Value
GTOW	1811.9 lb (822 kg)
Payload	176.4 lb (80 kg)
Figure of Merit	0.847
Rotor Radius	13.3 ft (3.75 m)
Installed Power	125 hp (93.2 kW)

# *Elysium* Technology Demonstrator



Helicopters have the perception for being too noisy, inefficient, polluting, and expensive for mass-scale use. The *Igor I. Sikorsky 24 Hour Hover Challenge*, and the *AHS 34th Annual Student Design Competition* attempt to change this impression by demanding unprecedented hover endurance and therefore spark innovations in fundamental rotorcraft technology.



In response to the *AHS Student Design Competition* Request for Proposal (RFP), the University of Maryland has designed the *Elysium* Technology Demonstrator, an autonomous **hybrid-electric** hover optimized **twin-rotor** helicopter. As an innovative application of existing state-of-the-art technology, *Elysium* represents a transformation in rotorcraft systems to achieve unparalleled levels of hover efficiency and endurance while minimizing total weight, mechanical complexity, and maintenance time.



As a **non-overlapping twin rotor**, *Elysium* avoids aerodynamic interference and parasitic power sinks, maximizing the on-board generated power efficiency in generating thrust. The two bladed rotors achieve superior aerodynamic performance with modest control loads through the combination of **high-lift and reflex airfoils**. *Elysium* is powered by a **hybrid propulsion system** that combines a state-of-the-art gas piston engine, **light-weight electric generator**, and highly efficient **electric motors** for unprecedented endurance capabilities. **Advanced composite structures** take advantage of the unique material properties to meet strength and stiffness requirements while minimizing weight.



# 24 Hour Hover Mission

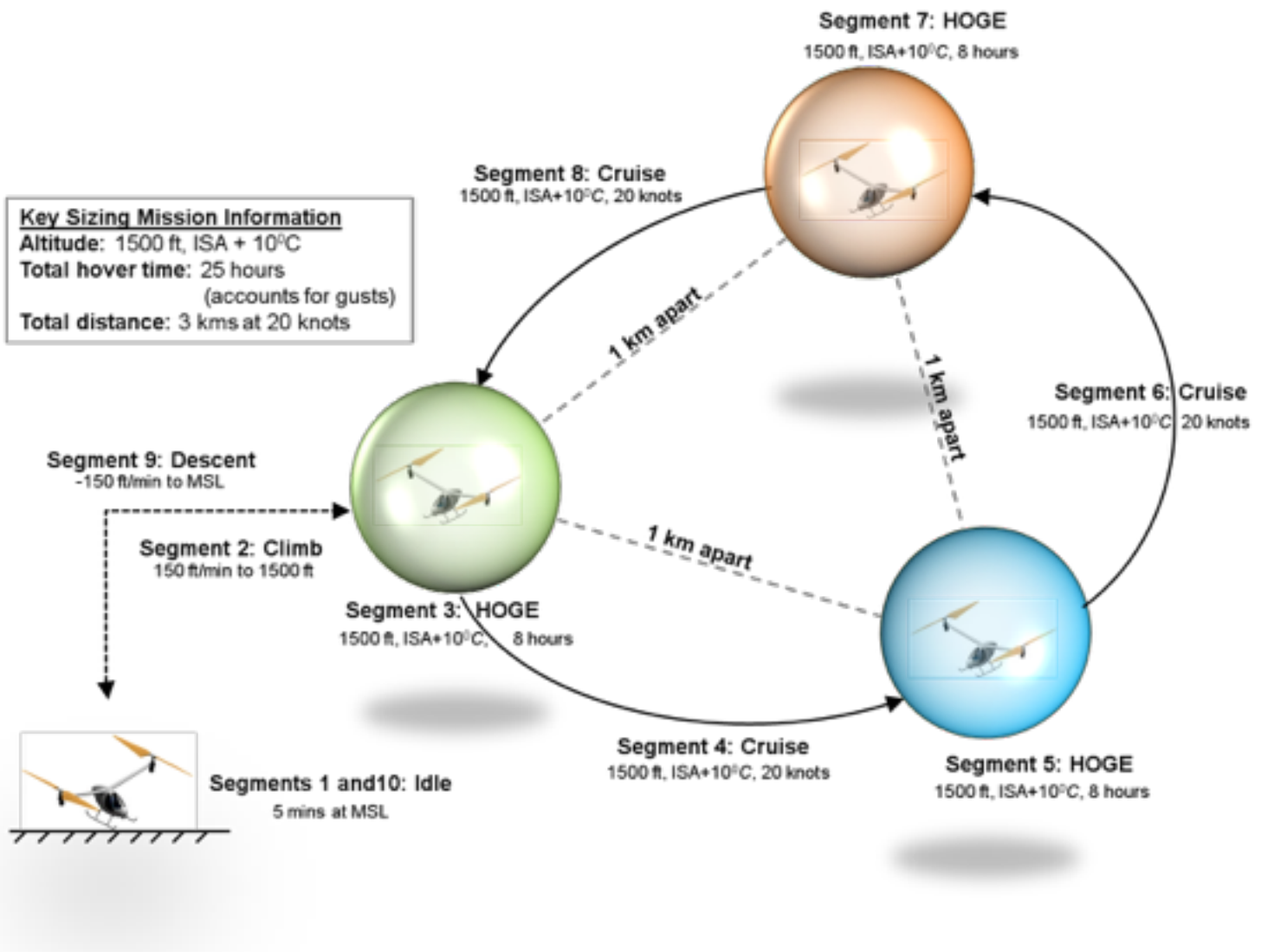

## Primary design drivers for long endurance hover

- **Hover Efficiency:** essential for achieving the required endurance at acceptable weight and power levels, *Elysium* exhibits a figure of merit of 0.847 throughout 24 hours
- **Superior Reliability:** *Elysium's* mechanical simplicity and multiple redundancy accomplishes the record setting 24 hour mission
- **Disturbance Rejection:** Innovative half-cyclic swashplate, RPM control and autonomous flight control system provides *Elysium* the ability to maintaining the strict hover requirements



# Elysium's 5-Year Development Plan

Elysium meets the RFP requirements of being designed, built and tested within five years, through the utilization of existing technology and innovative accelerated test plan.

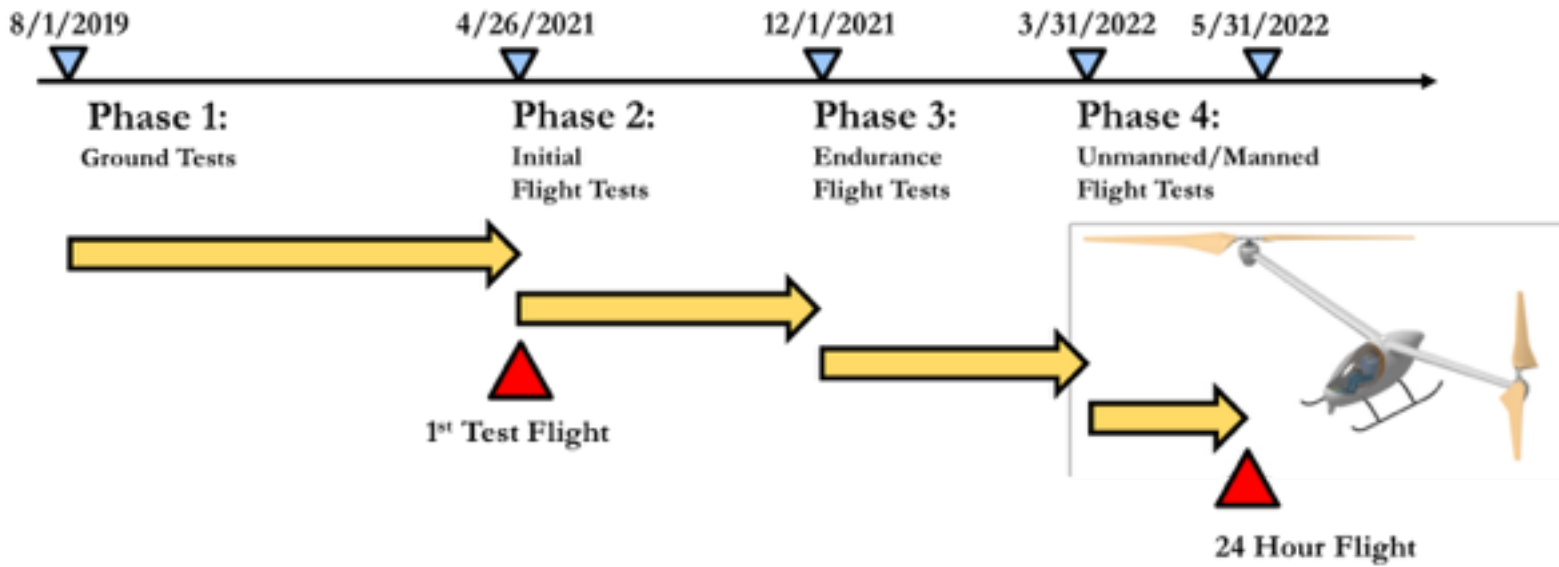

As a technology demonstrator, Elysium is slated to complete a rigorous flight testing schedule to validate the design and ensure safety. Concurrent component ground testing and simulator in the loop flight controls development reduce total development time. Elysium is designed to operate in a wide range of weather conditions including high temperature and rain.

### Elysium's Test Plan

Minimum requirements for Elysium before attempting the 24 Hour Hover Mission include:



	25	Flights
	350 hours	Total Run Time
	230 hours	Blades On
	80 hours	Hover
	30 knot	Flight Speed
	140	Engine Starts

### Allowable weather conditions

Wind gusts	Under 20 knots
Turbulence	Intermittent light turbulence
Temperature	ISA - 15°C to ISA + 10°C
Rain	Up to 0.1 inches per hour
Avoid lightning, snow and hail	

### Place (Number of days for flight testing in 2016)





# Vehicle Configuration

*Elysium* is designed to maximize hover efficiency, reliability, and technology maturity while minimizing gross take-off weight.

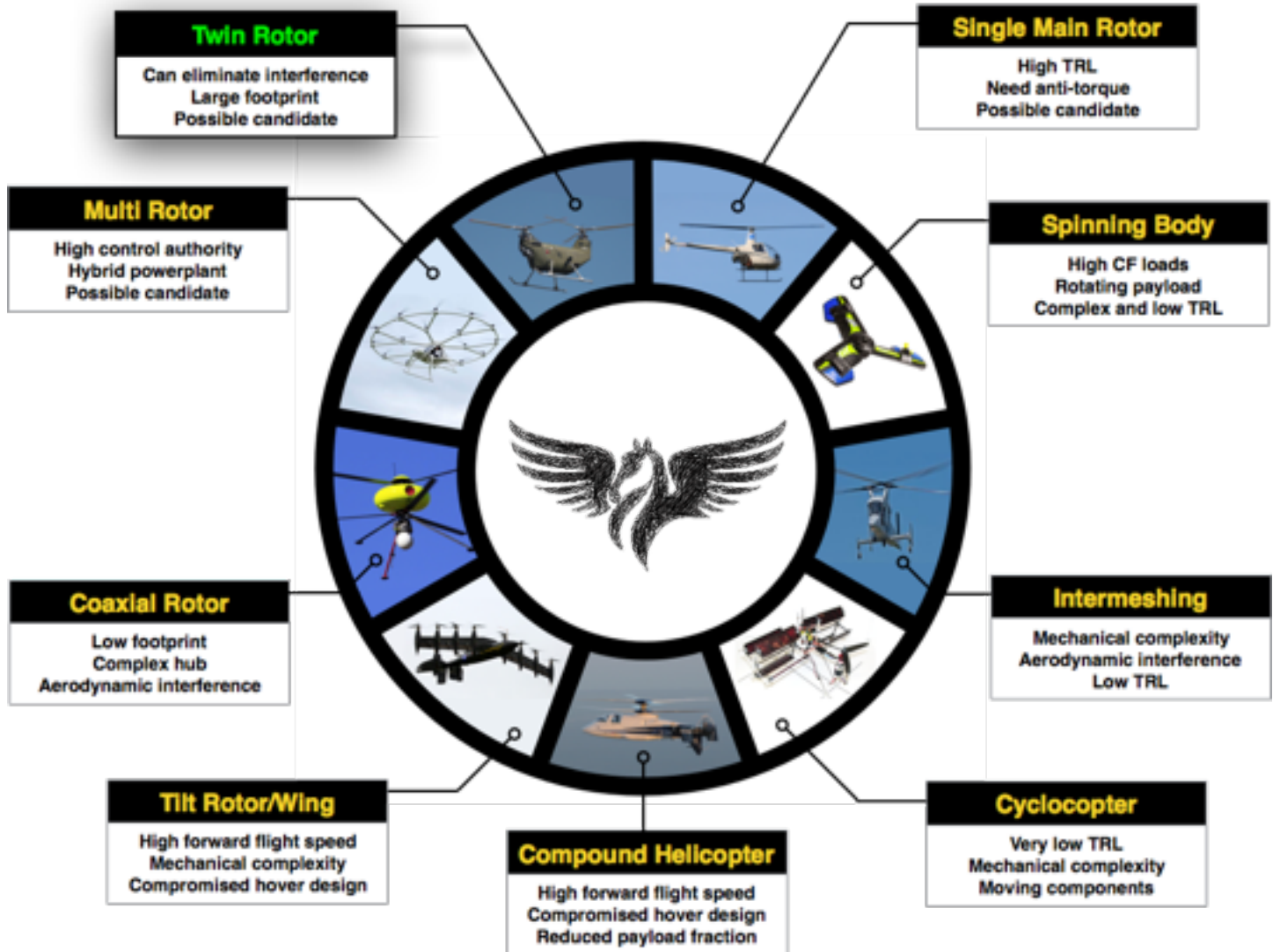

## Side-by-side twin-rotor configuration

- Avoids aerodynamic interference from overlapping rotors
- Minimize parts count
  - Capitalizes on advanced light weight composite structure for strength and weight
  - Utilizes advantages in mechanical simplicity of hybrid electric propulsion system
- Trade studies resulted in the **lowest structural weight** for the twin configuration



# Novel In-House Weight Model

The *Elysium* team developed an in-house sizing algorithm to compare novel configurations that have no empirical empty weight database. Historic trends cannot accurately predict the structural weight for configurations with two or more rotors using state-of-the-art technologies.

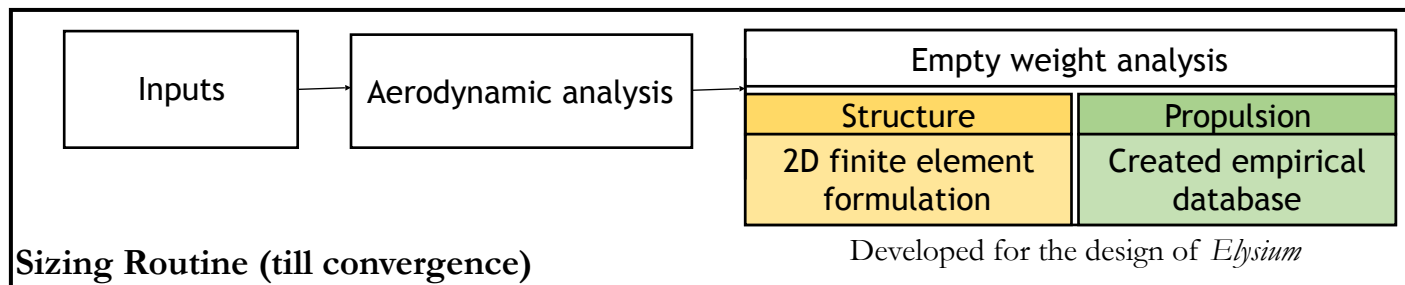

Physics based simulation treats rotors as points with attractive and repulsive forces acting on it  
**In-house developed force-directed algorithm**

Rotor positions alters structural weight of airframe

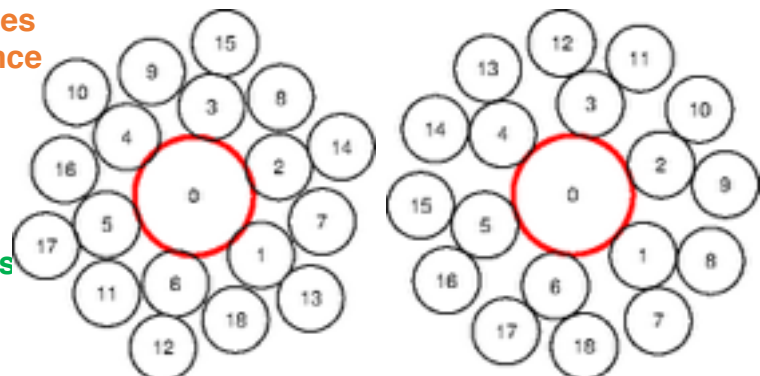
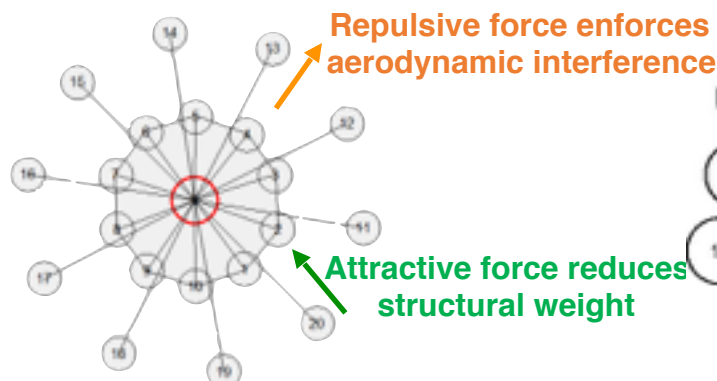

Initial rotor configuration

18 rotor configuration 1

18 rotor configuration 2

Twin rotor configuration most efficient from a gross take-off weight and minimum fuel standpoint

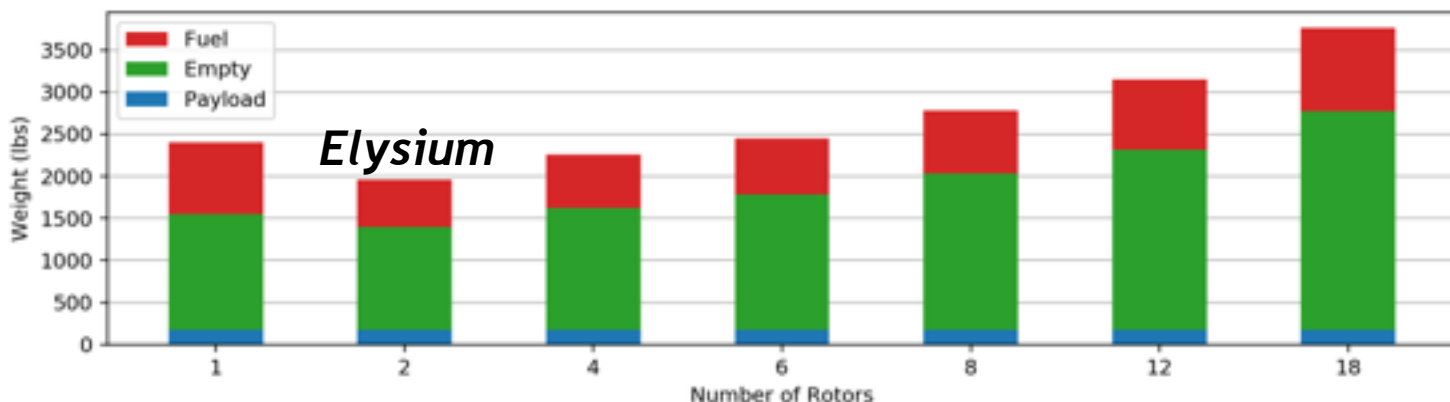



# Optimized Blade Aerodynamics

*Elysium* enjoys unprecedented aerodynamic efficiency through RPM scheduling to maintain constant blade loading coefficient, optimized geometry and novel airfoil design suited to the medium Reynolds number range.

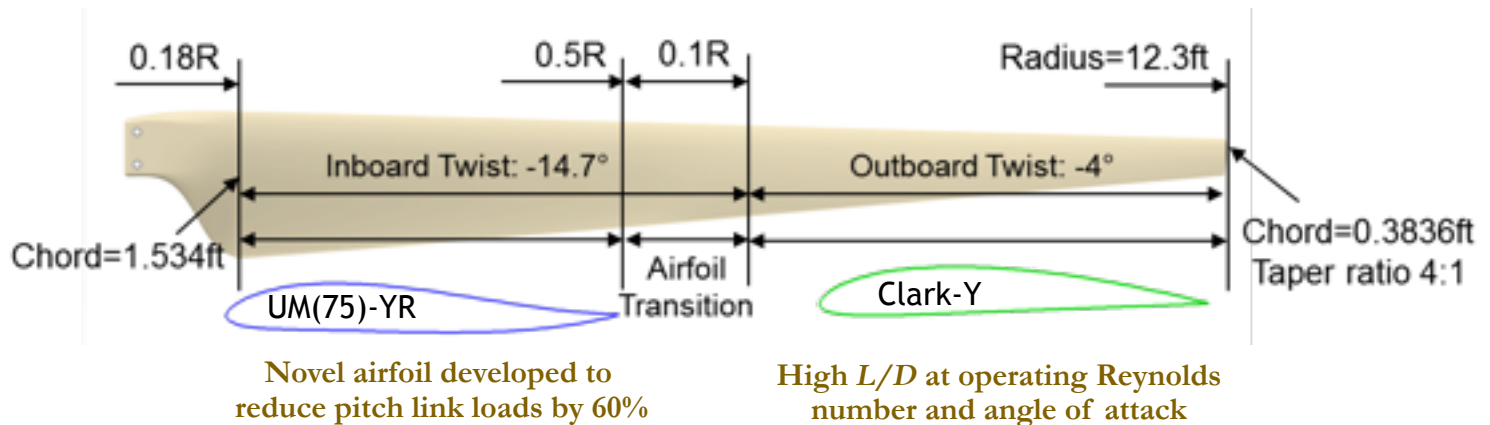

Robust aerodynamic design results in an unprecedented figure of merit of 0.847 over a broad range of flight conditions resulting in twice the power loading of a Robinson R22.

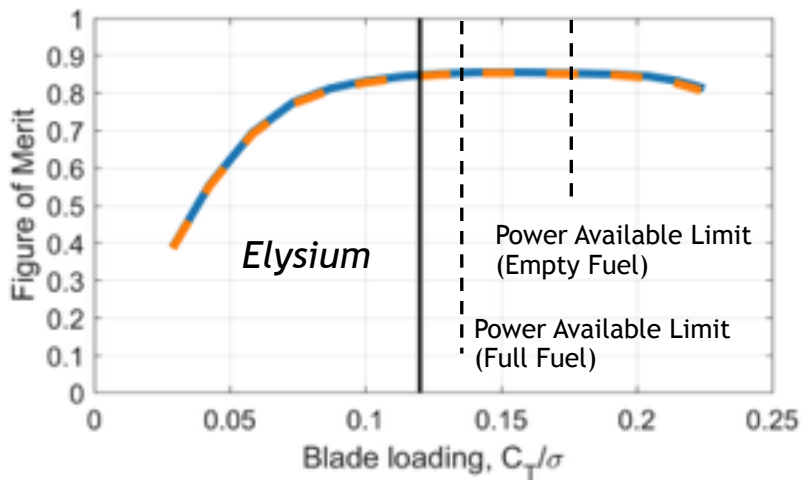

Rotor Performance Characteristics	
Figure of Merit	0.847
Disk Loading	1.9 lb/ft <sup>2</sup> (9.3 N/m <sup>2</sup> )
Blade Loading	0.119
Tip Reynolds	0.7 – 1.0 million
Tip Mach	0.33 – 0.39
Power Loading	22.4 lb/hp (13.6 kg/kW)

A suite of in-house algorithms was developed to ensure peak aerodynamic efficiency of *Elysium*'s twin rotor system throughout the 24 hour mission.





# Robust Aeroelasticity

In-house non-linear Euler-Bernoulli beam and cross-sectional analysis tools ensure *Elysium's* blades can withstand the loads of the 24 hour operating environment. The blade structure accounts for both steady and vibratory loading conditions in the design of geometric properties and material selection for the skin and spar.

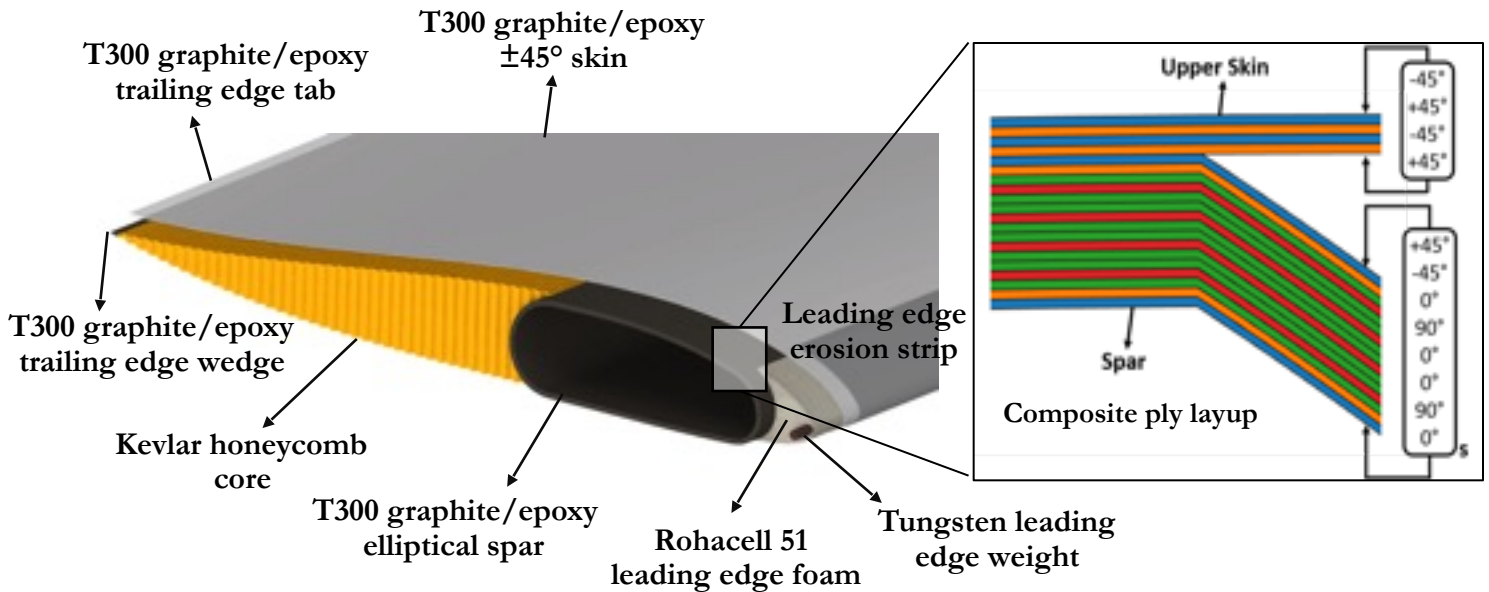

Detailed structural design grants *Elysium* the freedom of continuous RPM scheduling while ensuring avoidance of aeroelastic instabilities. Through the use of advanced materials and tuning masses, rotor is free from pitch-flap/flap-lag flutter, pitch divergence, and ground resonance.

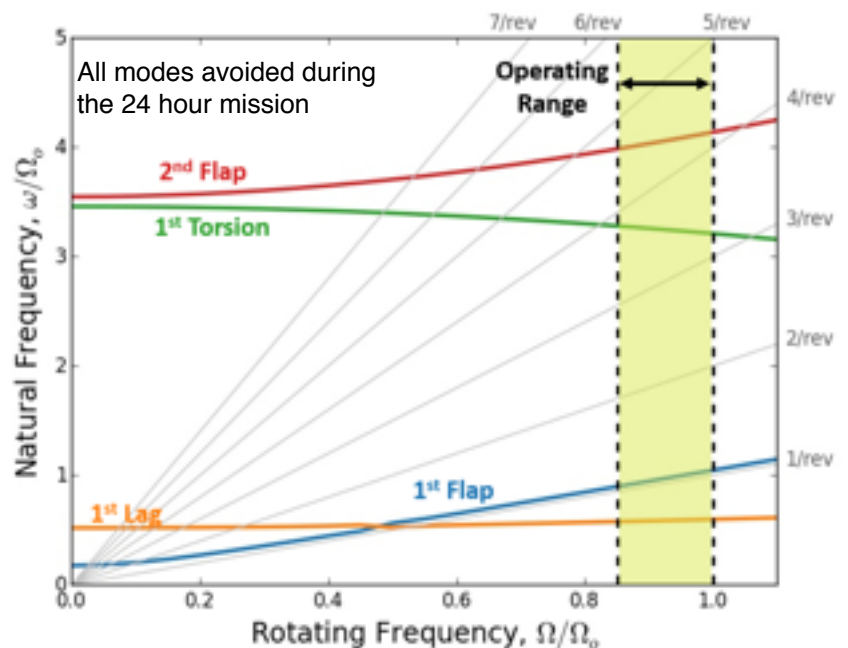
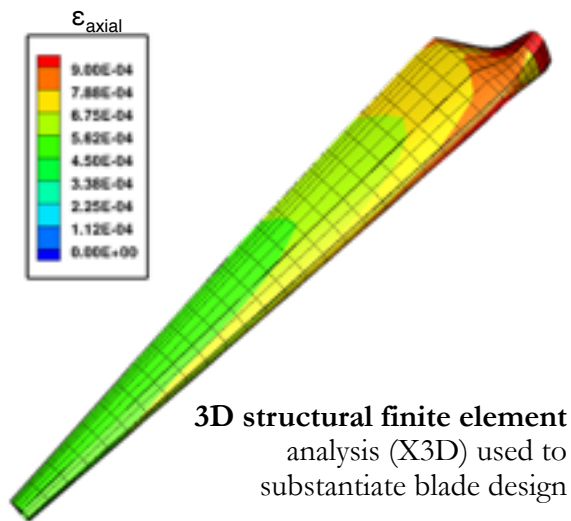

# Advanced Structural Design



Carbon fiber frame enables low structural weight

Wing box and bulkheads transmit loads while establishing a protective firewall

Innovative arm design combines aerodynamic and structural considerations to maximize performance

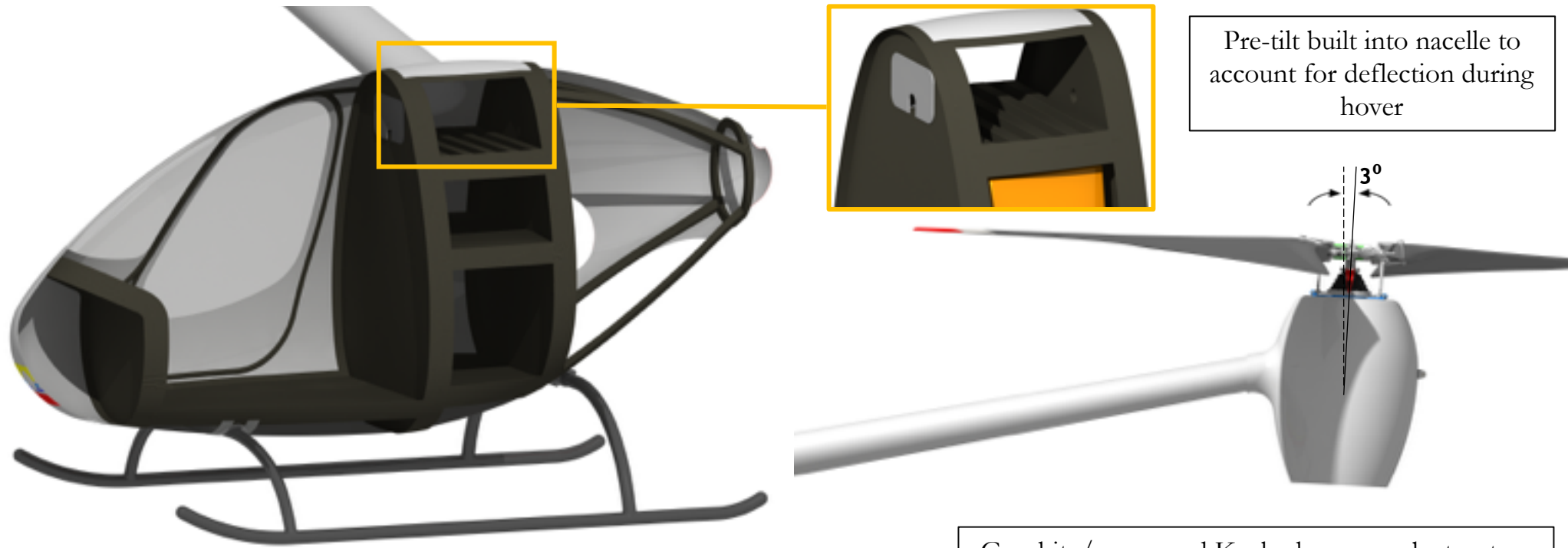

Pre-tilt built into nacelle to account for deflection during hover

Graphite/epoxy and Kevlar honeycomb structure maintains strength in a lightweight structure

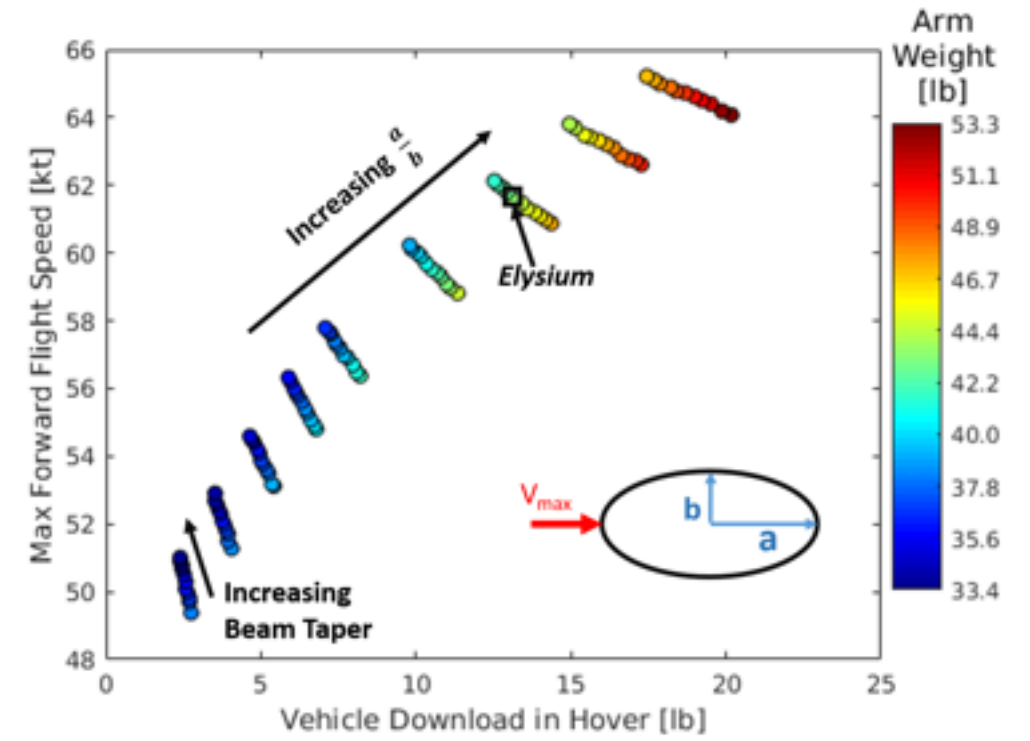

Various flight load cases substantiated using an in-house team developed 3D finite element analysis.



Removable fuel tanks and detachable arms provide a multi-mission flexibility and ease of transportation

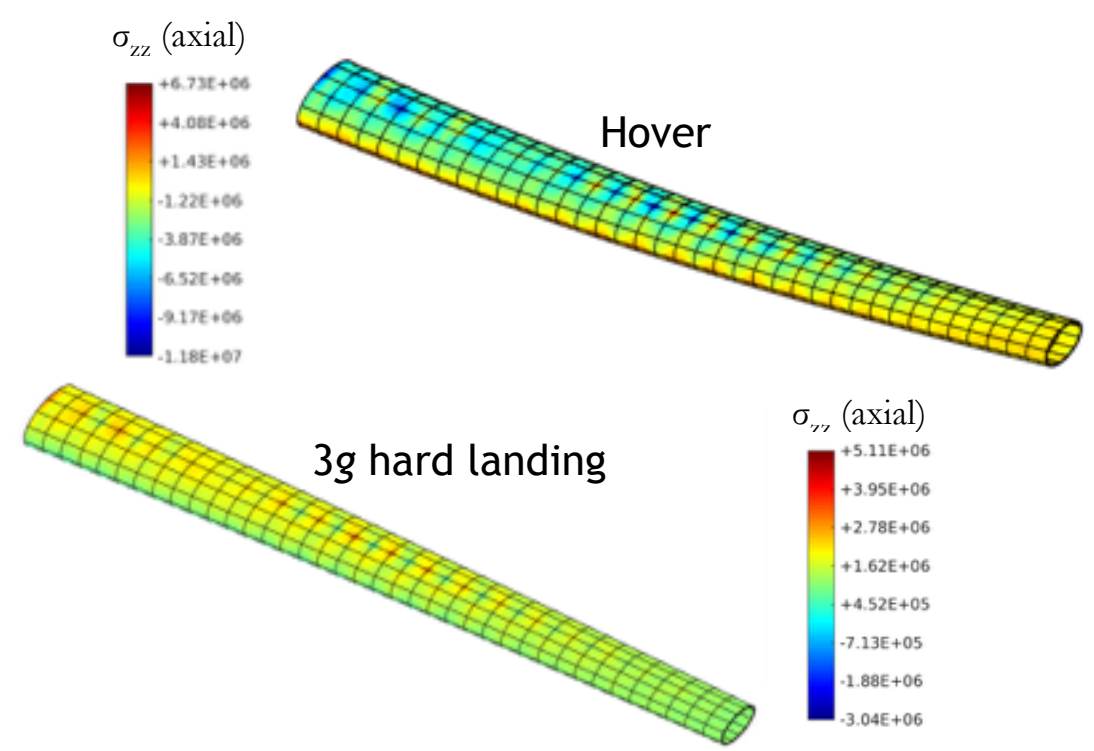
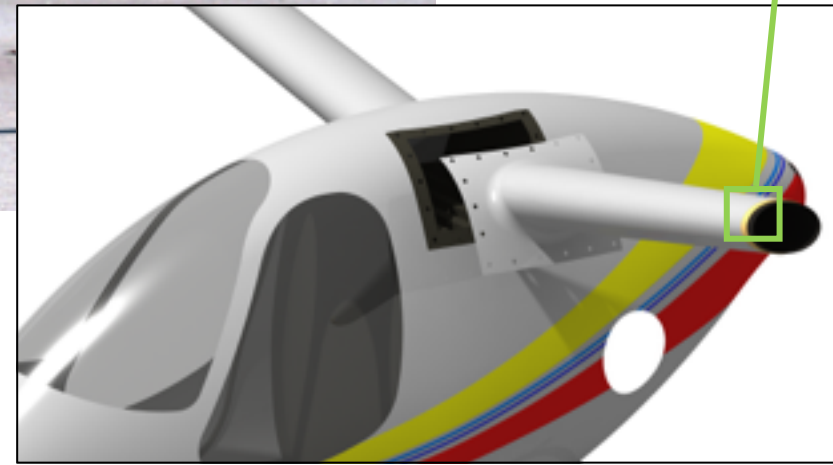
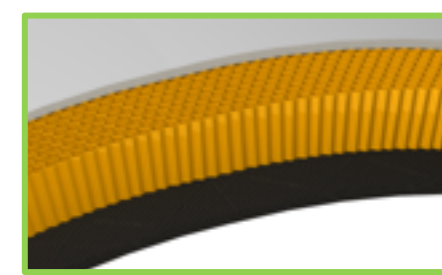



# Hybrid Electric Powertrain

*Elysium's* hybrid propulsion design offers great reliability through mechanical simplicity and redundancy. The architecture also prepares for insertion of future advances in electric aviation technology of the decades to come.

## Hybrid-Piston Specifications

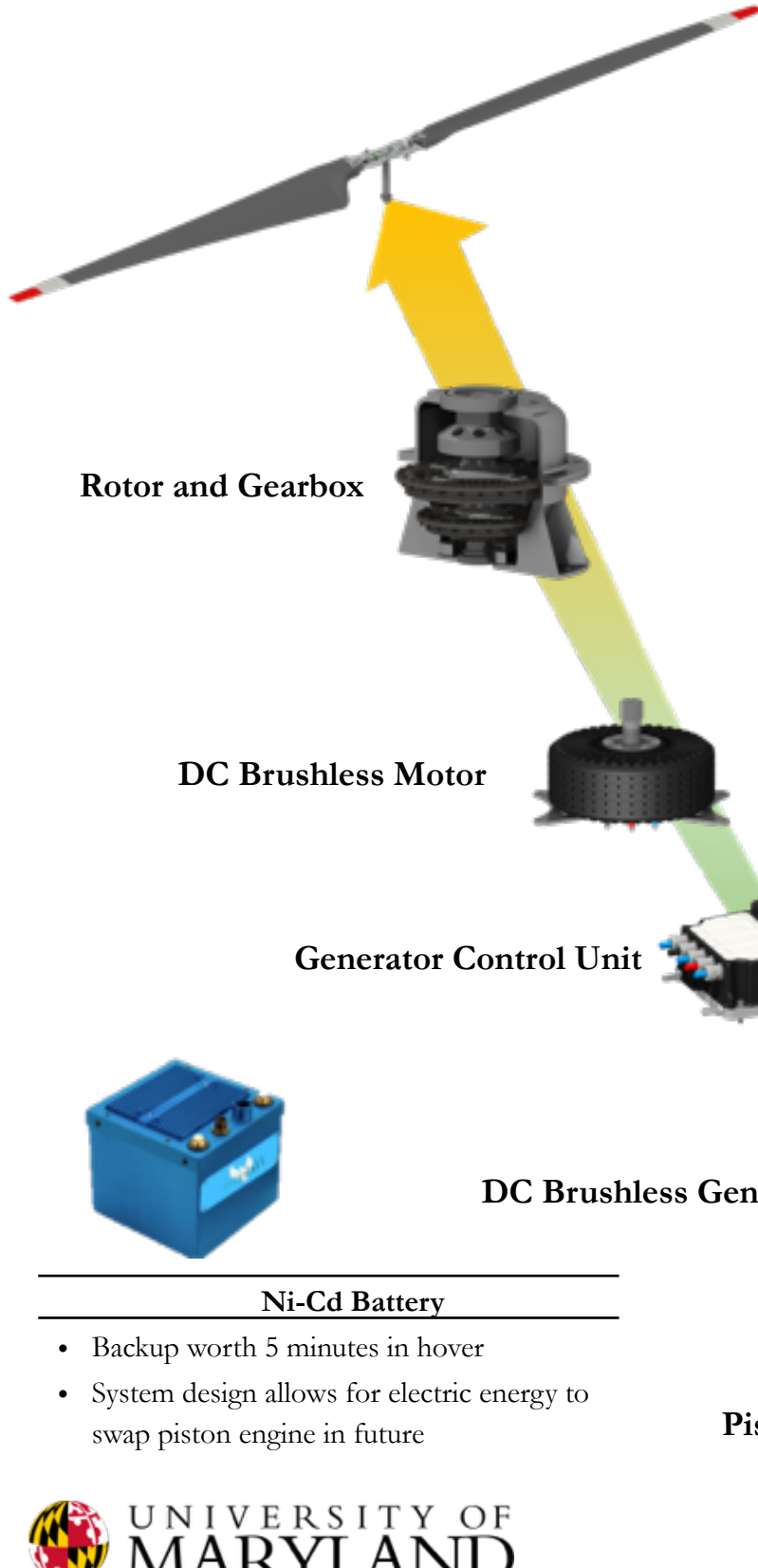
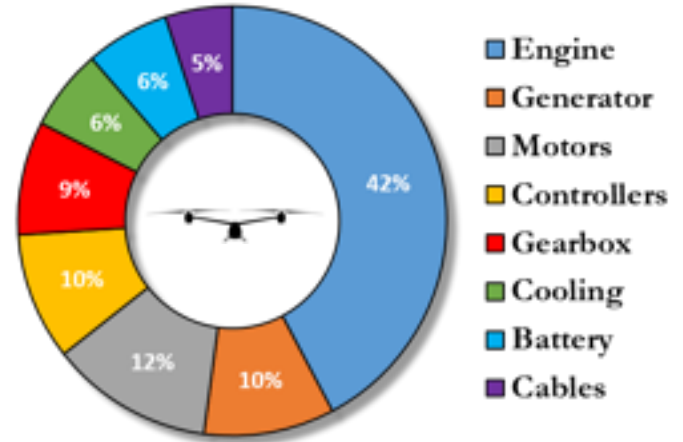

### Piston Engine

- 125 hp (104.4 kW) at 2,800 RPM
- Ultralow-friction cylinder surfacing
- Reliable side-valve orientation

### Generator and Electric Motors

- Solid-state diode brushless DC
- 97% Efficiency
- Liquid cooled

### Rotor Gearbox

- 8.12:1 two stage planetary reduction
- Centrifugal-Sprag combined clutch
- Nitralloy 135M Crowned spur gears

### Ni-Cd Battery

- Backup worth 5 minutes in hover
- System design allows for electric energy to swap piston engine in future

### Piston engine



# Gearbox Design

Dual stage planetary gearbox design to allow motor and rotor to operate at most efficient rotational speeds of 8.12:1 reduction ratio

- Elektron 21 magnesium housing
- Combined Centrifugal-Sprag Clutch
- Stage 2: 2.8:1
- Stage 1: 2.923:1

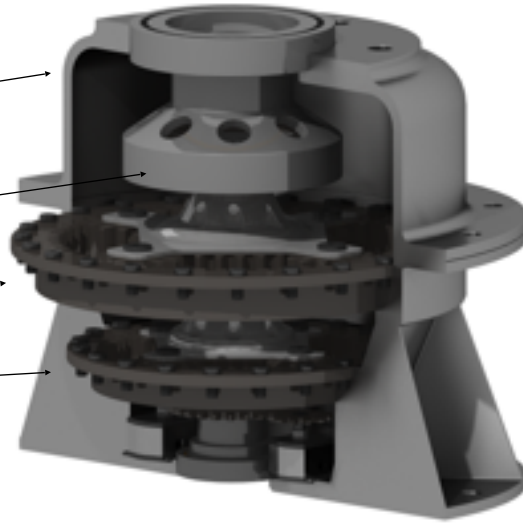

## Combined Centrifugal-Sprag Clutch

Allows for both no load motor start up and safe decoupling in the case of autorotation



Carburized Steel Sun & Planet Gears

## Two Stage Planetary Gears

Superfinished crowned spur gear design ensures reliability and maintains a system Safety Factor of 1.34 at 120% over torque load



Nitralloy 135M Ring Gears



# Performance

*Elysium* enjoys a generous operating envelope in hover at high altitudes and temperature conditions and provides an unparalleled capability to perform missions requiring long hover times – surveillance, civilian and military monitoring, wireless communications platform.

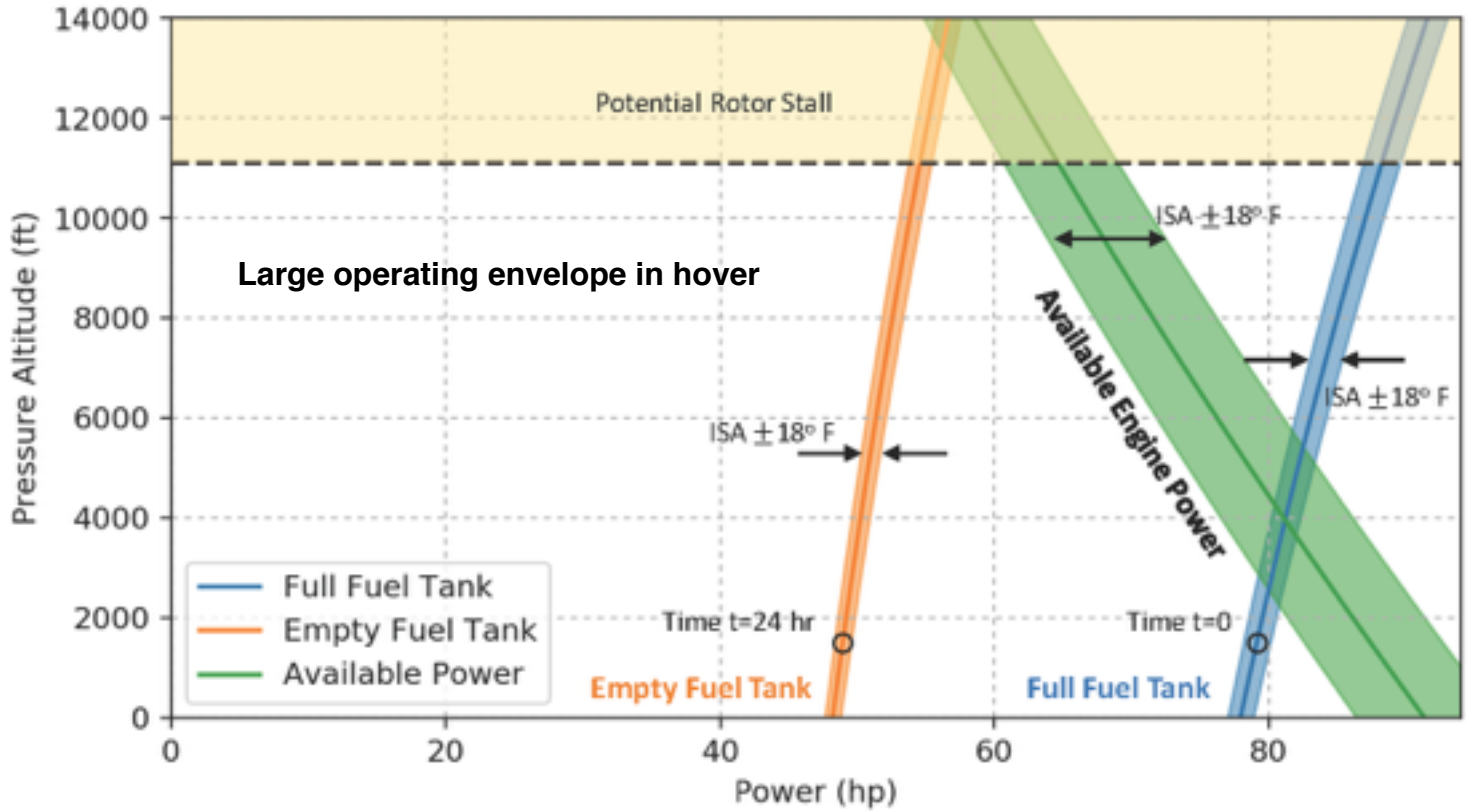

While the rotor blades are designed for excellent hover performance, the high-stall margin of the rotor blades allow for good forward flight performance, which further expands the mission flexibility of *Elysium*.

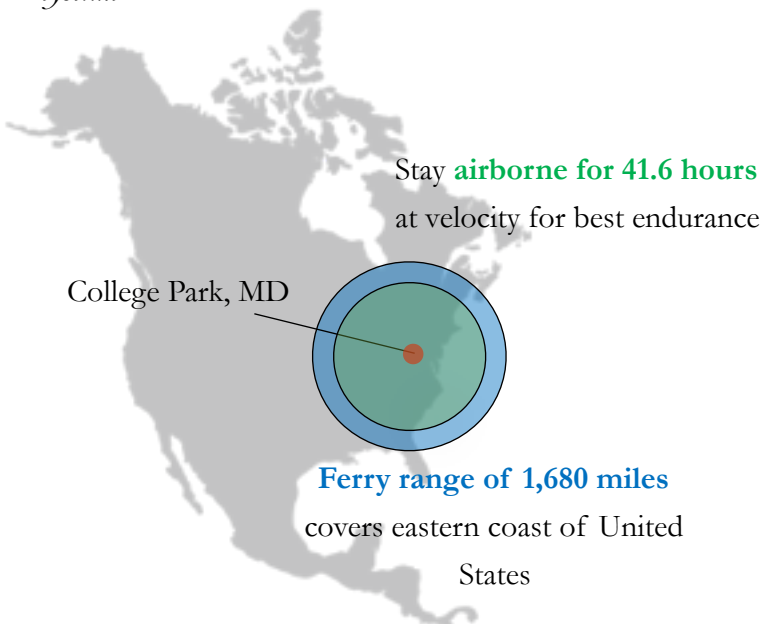

Vehicle Performance			
HO VE R	Maximum hover (ideal conditions)	33 hours	
	Autorotative index	10.3 (similar to CH53)	
FO RW AR D	Max range	1,680 miles	
	Max endurance	41.6 hours	
	Velocity	Best range	49.2 knots
		Best Endurance	30.3 knots
		Maximum	59.8 knots



# Control Strategy

Electric motors provide quick response to flight commands. The simple electric transmission is also easily maintained and checked before flight in a matter of seconds.

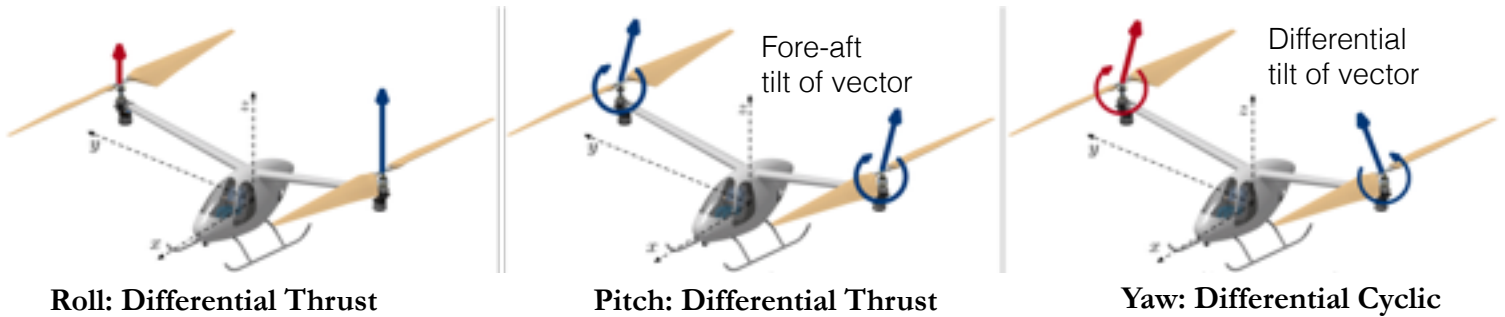

Collective and half-cyclic actuation at each rotor provide full-state controllability.

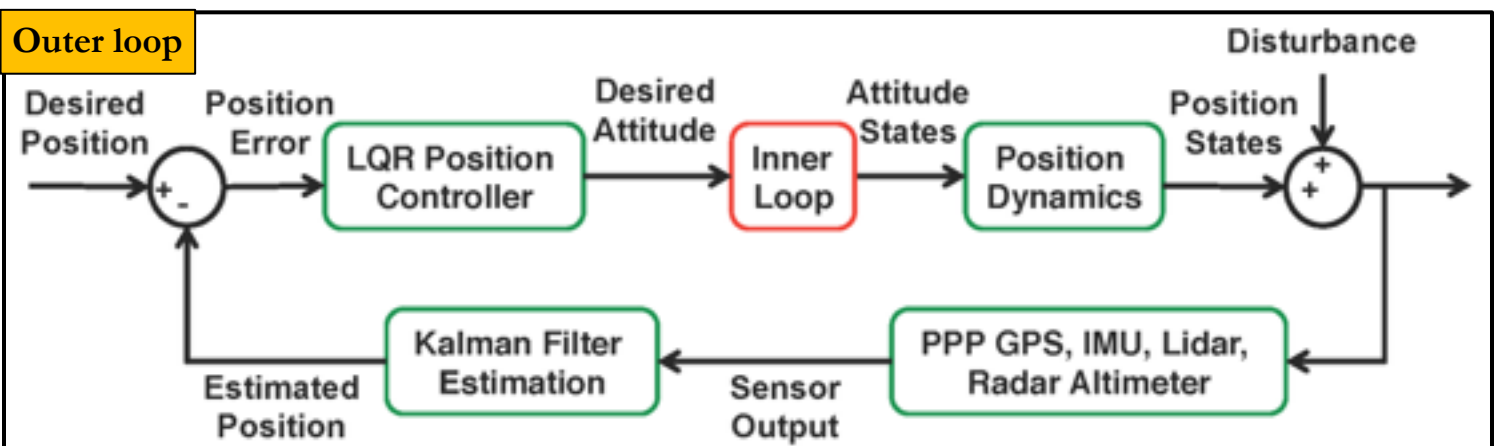
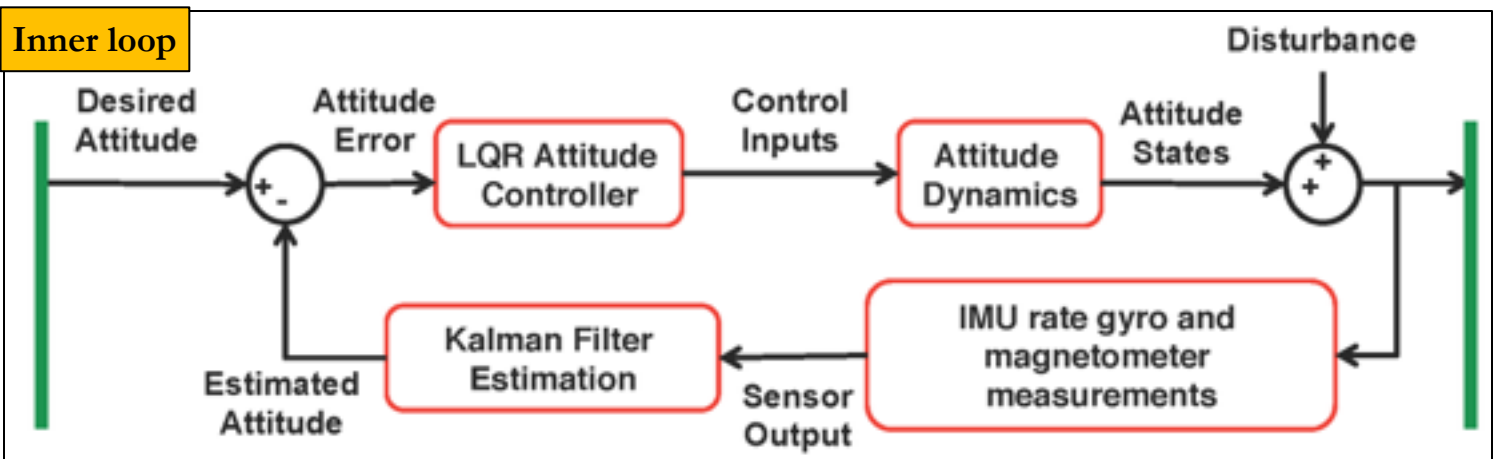

Autonomous waypoint navigation in conjunction with the avionics suite facilitate translating flight, and an optimized hovering controller provides stability in the presence of gusts.



# Rejecting Gusts

Gust tolerance is crucial for Elysium to hover precisely for the duration of the mission. The control strategy ensures station-keeping while staying within the 20 m radius sphere.

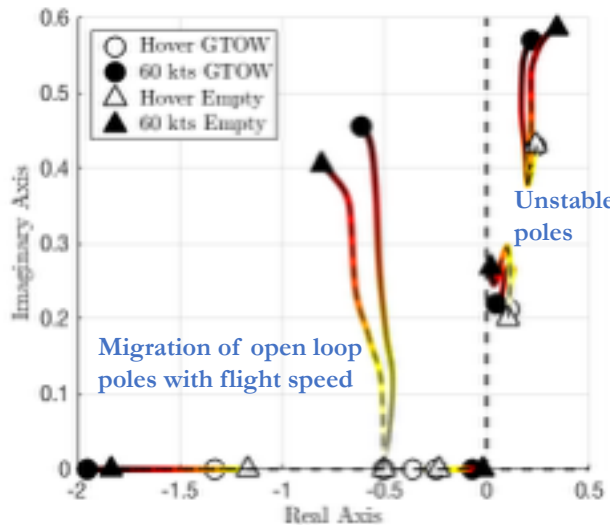

Open Loop Stability

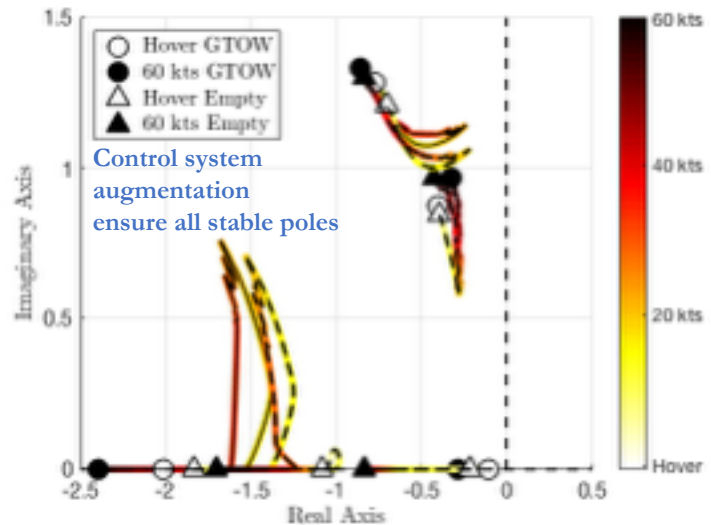

Closed Loop Stability

Open loop stability indicates unstable modes, which are stabilized through the implementation of the control system, indicated by the closed loop poles.

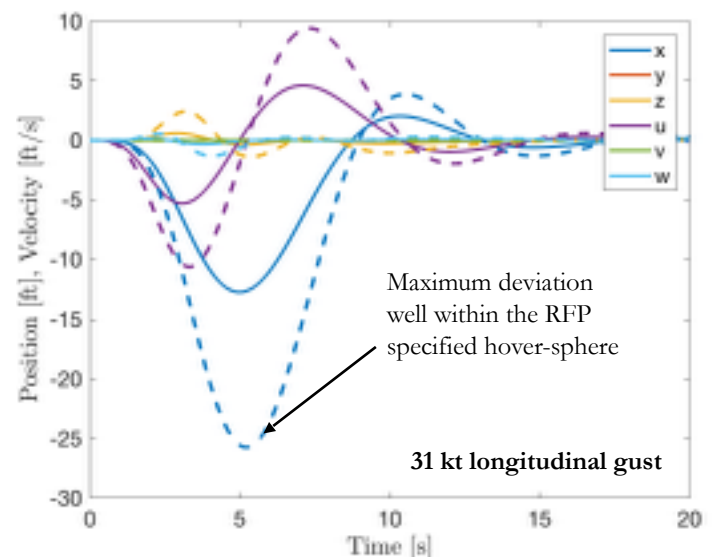
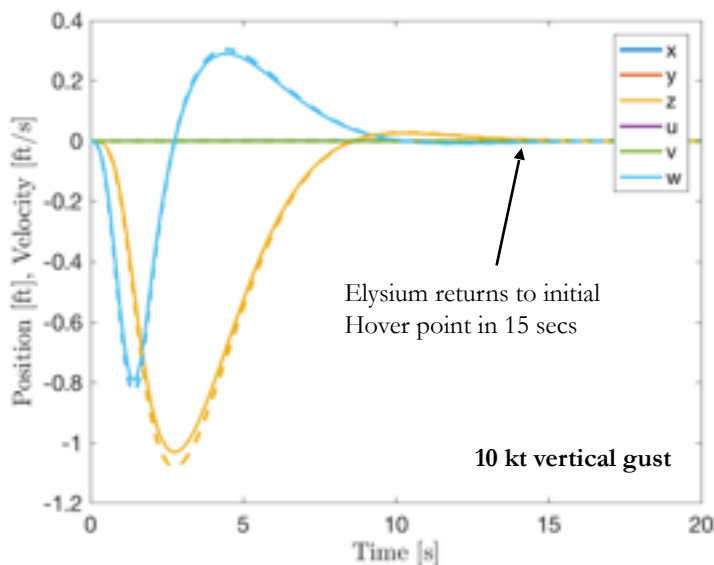

Time varying response to gust reveals that *Elysium* can both maintain attitude stability and return to the desired location inside the hover station.

Component	Max value
Longitudinal gust	31 knots
Rotational gust (pitch)	23.5 rad/s
Vertical gust	10 knots



# Safety in Numbers

Safety, redundancy and simplicity are entrenched in *Elysium's* design philosophy from the initial conceptual stage to the assembly of specific components for the various sub-systems.

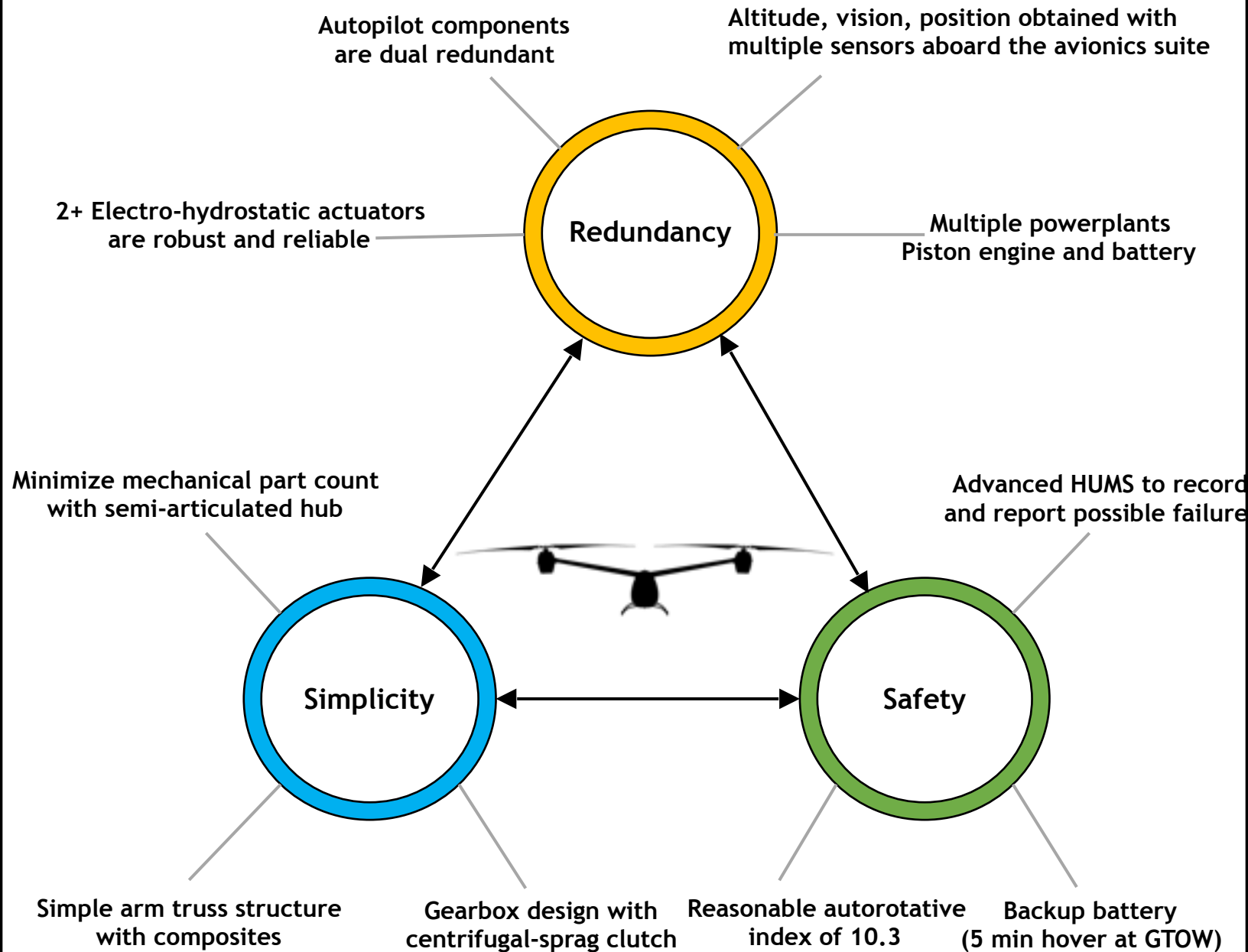

The safety driven system design allows *Elysium* to perform a challenging 24 hour hover with unprecedented performance and capability.

# Comprehensive Avionics Suite

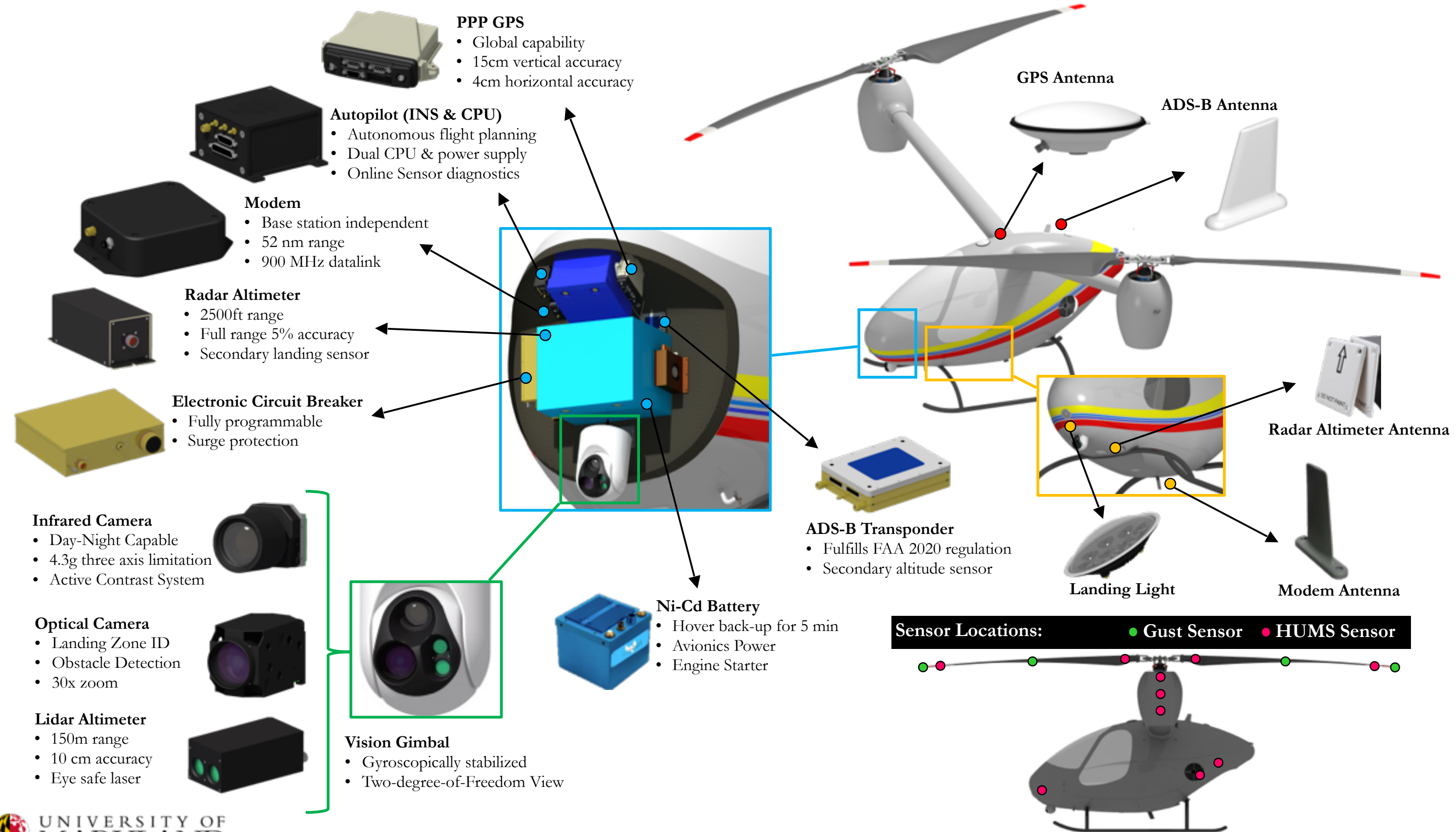



# Swashplate and Hub Design

Compact **semi-articulated hub** provides articulation through elastomeric bearings, therefore eliminating mechanical hinges, while maintaining favorable flap loading

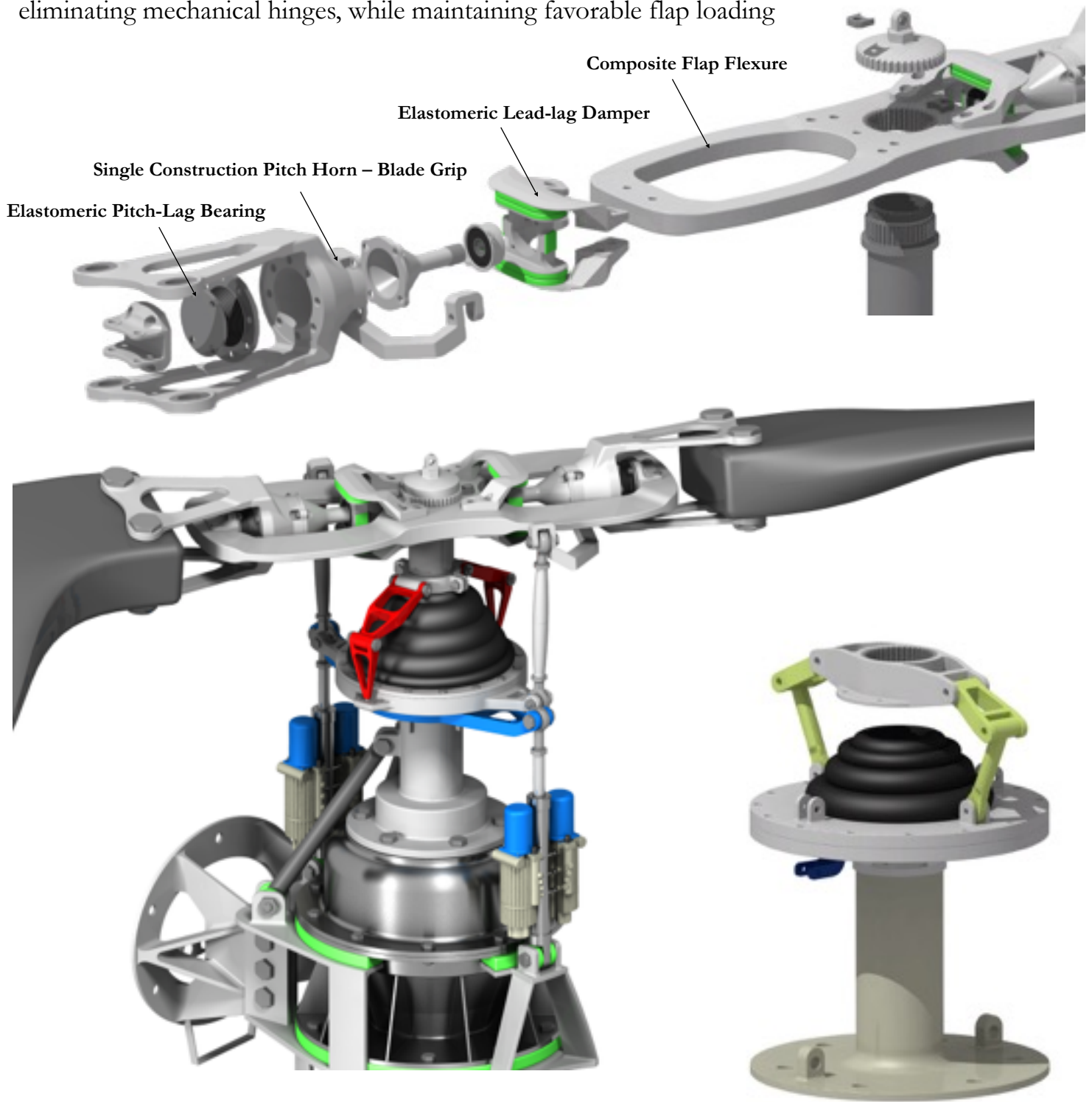

**Half-cyclic** control reduces system weight and part-count, through limiting the swashplate to a single degree of rotation, while satisfying gust response requirements



# Hovering Aerodynamics: Vortex Signature

*Elysium's* rotor design choices in hover were substantiated through the use of higher fidelity in-house numerical tools. Careful consideration of vortex signature is key to the high efficiency of the helicopter in hover.

Focus area	Methodology	Outcome
Effect of anhedral tip-shape	3D RANS	<ul style="list-style-type: none"> <li>Distributed vorticity</li> <li>Diffused tip-vortex</li> <li>Increased vortex-miss distance</li> <li>Minor increase in required power</li> </ul>
Fuselage download	Free-vortex wake	<ul style="list-style-type: none"> <li>Wake does not interact with fuselage</li> <li>Eliminates fuselage download</li> </ul>

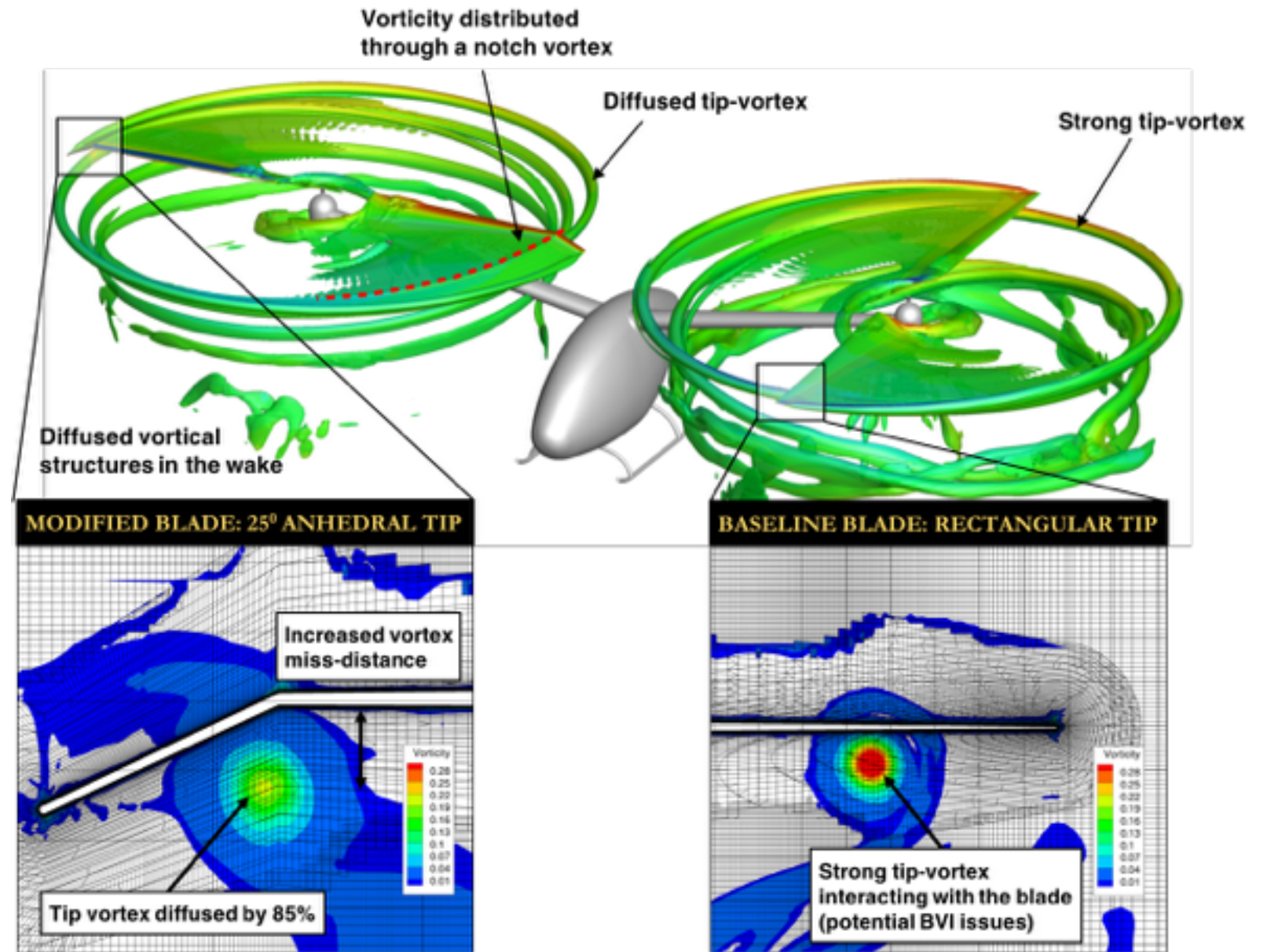
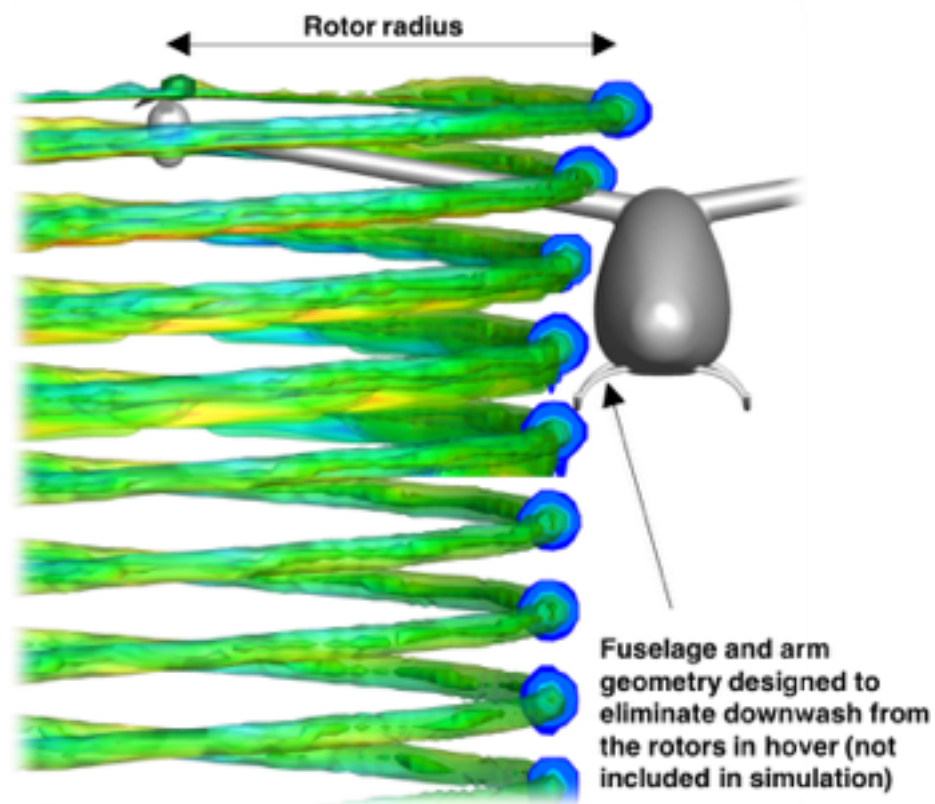

NOTE: Each rotor solution executed in isolation without fuselage

Lateral Rotor Placement

Eliminates rotor-rotor and rotor-airframe interference

25° Anhedral tip

Alleviates potential BVI vibration and noise



# Hardware Validation: Motor Testing

As a 24 hour endurance aircraft, *Elysium* must demonstrate superior reliability and safety. Elysium's design team tested the effects of liquid and air cooling on long endurance DC Brushless Electric motor operation

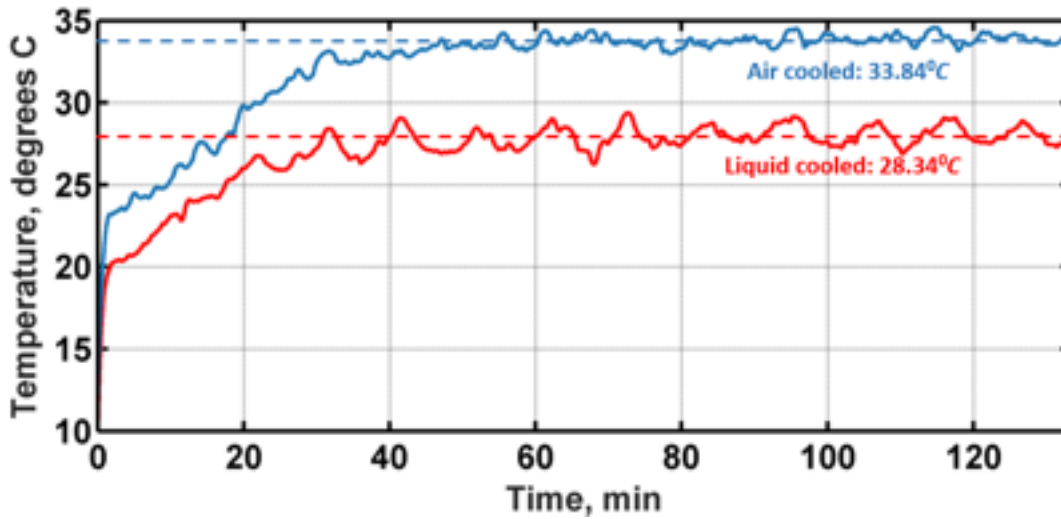

As predicted prior to testing, the liquid cooled motor was capable of maintaining a more efficient temperature as compared to the air cooled, which validates *Elysium's* design choice to include liquid cooling for electric motors and generator, for efficiency and reliability benefits.

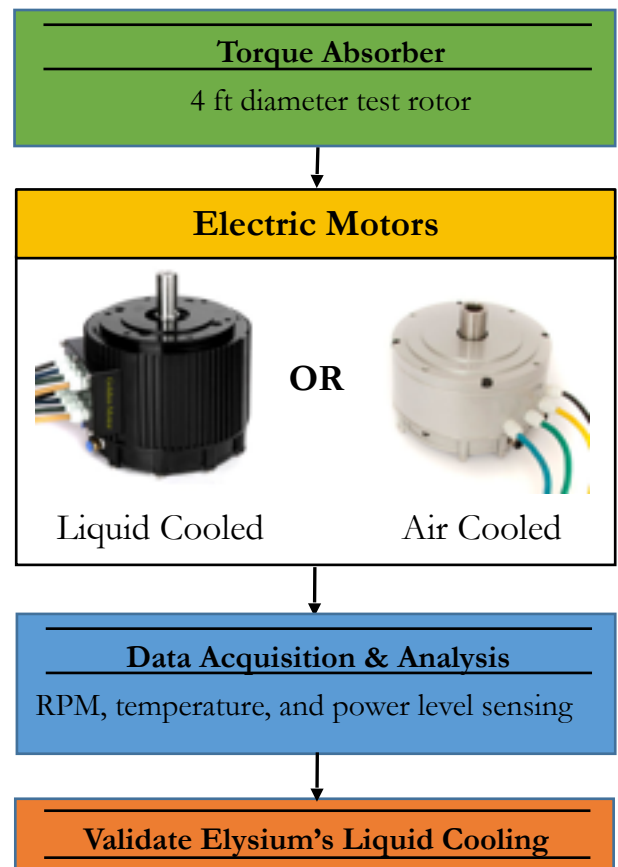
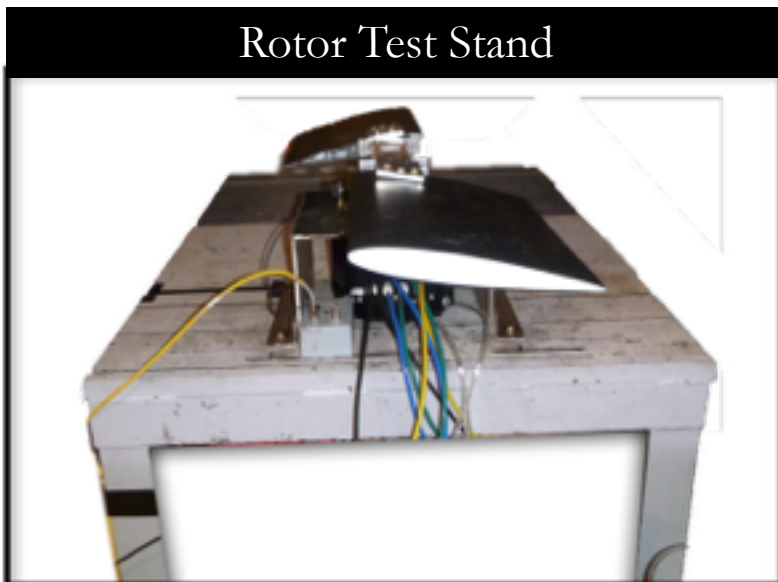



# Summary

Developed in response to the Request for Proposal for the 2016 AHS Student Design Competition, *Elysium* is a complete system solution that is efficient, reliable, safe and redundant, designed specifically to accomplish the Sikorsky 24 hour hover challenge. Guided by a comprehensive in analysis of aerodynamics, structural dynamics and rotor aeromechanics at the University of Maryland; including tools that were developed during the design process, *Elysium* meets and exceeds the requirements specified in the RFP.

- Twin non-overlapping rotor configuration to **minimize gross take off weight** and fuel weight
- Variable rotor RPM scheduled through 24 hours to ensure **constant blade loading coefficient**
- Exceptional **figure of merit of 0.847** through the mission
- Novel reflex airfoil developed to **minimize pitch link loads**
- Overall simplistic design philosophy to **enhance reliability**
- **Semi hingeless** two-bladed rotor
- Piston-electric hybrid propulsion allows for electric aviation **expansion in the future**
- Synergetic avionics suite and autonomous control system to **hover under gusty conditions**

