



Alfred Gessow Rotorcraft Center
Department of Aerospace Engineering
University of Maryland
College Park, MD 20742

Matthew Arace
Graduate Student (Team Lead)
marace@umd.edu

Peter Ryseck
Graduate Student
pryseck@umd.edu

Paulo Arias
Graduate Student
pariasj@umd.edu

John Soong
Graduate Student
jsoong1@umd.edu

Akinola Akinwale
Graduate Student
aakinwal@umd.edu

Eric Greenbaum
Graduate Student
egreen98@umd.edu

Dr. Inderjit Chopra
Faculty Advisor
chopra@umd.edu

Dr. Vengalatore Nagaraj
Faculty Advisor
vnagaraj@umd.edu

Dr. Anubhav Datta
Faculty Advisor
datta@umd.edu



Alfred Gessow Rotorcraft Center
Department of Aerospace Engineering
University of Maryland
College Park, MD 20742

To the Vertical Flight Society:

The members of the University of Maryland Graduate Student Design Team hereby grant VFS full permission to distribute the enclosed Executive Summary and Final Proposal for the 39th Annual Student Design Competition as they see fit.

Thank you,

The UMD Design Team



39th Annual VFS Student Design Competition

All-Electric Accessible VTOL Air Taxi

Sponsored by Bell



UNIVERSITY OF
MARYLAND

Alfred Gessow Rotorcraft Center
Department of Aerospace Engineering
University of Maryland
College Park, MD 20742



Starling: Sound of the City

First introduced by Shakespeare enthusiasts in Central Park, New York in the late 19th century, the European Starling is one of the most common birds encountered in the city. As an accomplished mimic capable of copying the sounds of other birds and animals, even replicating a car alarm or ringtone, it has made the city its home.



Inspired by these versatile vocalists, the *Starling*, designed by the University of Maryland Graduate Design Team, is an **all-electric, highly efficient air taxi** with **acoustics that blend with urban soundscapes** unlike a traditional helicopter.

The *Starling*, a 2,495 kg (5,500 lb) 5-seat **quad tilt-rotor**, is specially designed to navigate through dense and dynamic, obstacle-prone cities and **transition** to an airplane quickly to travel **far and fast**.

The **streamlined** aircraft is elegantly designed for **robustness** and **fault tolerance**, making clever use of onboard electrical systems to provide a **comfortable** flight for passengers. The *Starling* is intentionally crafted as a **passenger first** vehicle using the principle of **universal design**. **Accessible** and **equitable** features elevate *Starling* from just another taxi service to one that is **attentive** of all and any potential passengers, particularly for those who will require additional care. With a **high payload capability of 25% gross weight**, *Starling* is ready to carry you wherever you want to go, whenever you want to go, cleanly, quietly, and peacefully, whoever you are.

Specified 161 km Air Taxi Mission Profile

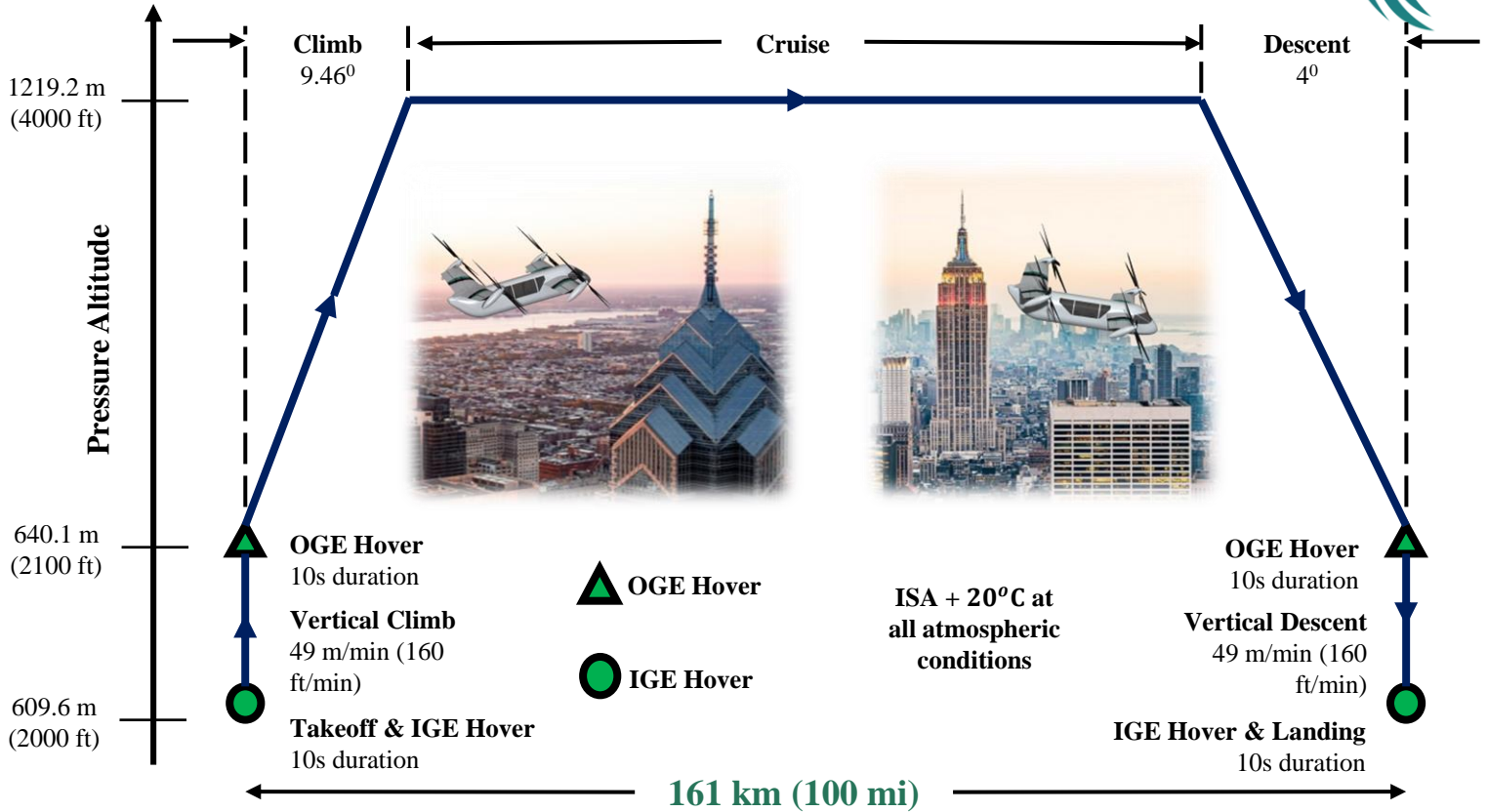

Starling capability while carrying max payload of 590 kg (1,300 lb)

	RFP Requirement	Starling
Range	161 km (100 mi)	175 km (108.7 mi)
Compactness	≤ 15.24 m (50 ft) length & width	9.1 m (30 ft) x 14.6 m (48 ft)
Rotor Radius	-	2.6 m (8.5 ft)
Re-configurable Cabin	-	✓

Vehicle Configuration



Configuration Generation from the Ground Up

Wing	Number of Hubs	Rotor Type	Shaft Type
Fixed Wing	Single Hub	Stacked Rotor(s)	Fixed
Tilting Wing	Multiple Hubs	Single Rotor(s)	Transitioning
No Wing		Combination	Combination

No Wing + Single Hub + Single Rotor + Fixed Shaft =



SMR



Driving Criteria

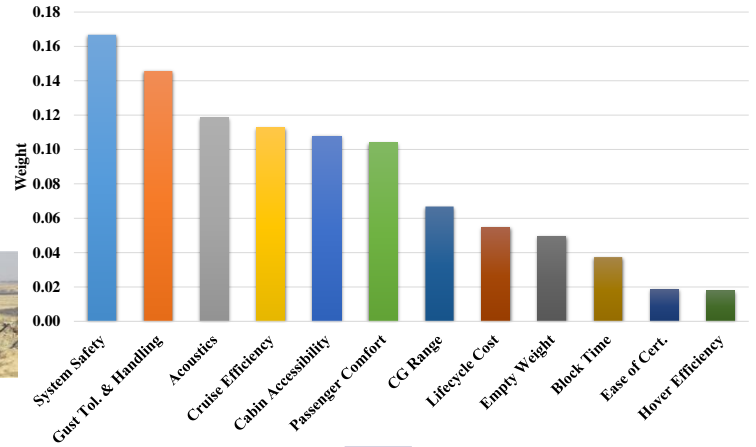

Downselect

Multicopter Tilt-Rotor "Stopped" Rotor



Comprehensive Trade Study



Quad Tilt-Rotor

- Distributed electric propulsion
- Superior cruise efficiency
- Low-profile, low acoustic signature
- Fault tolerant power architecture
- Low downwash
- Accessible cabin
- Reconfigurable seating
- Autonomous G&N

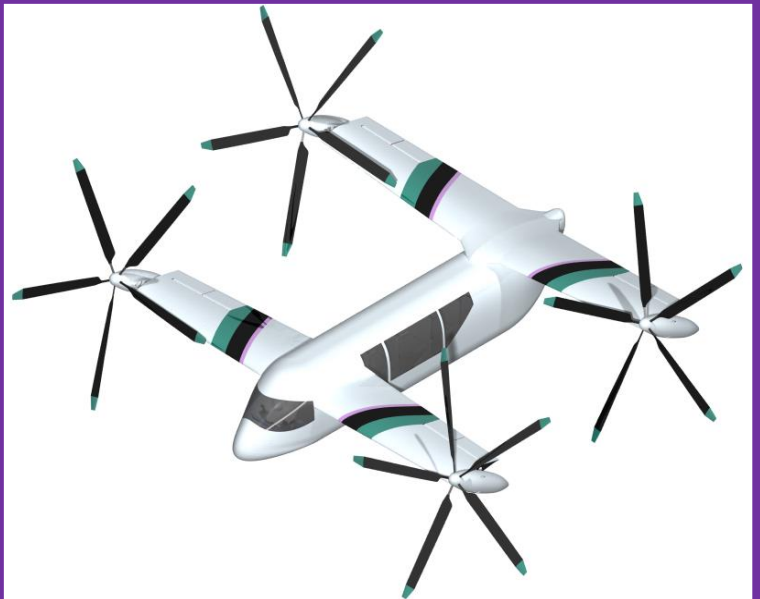



Variable Speed Proprotor Design

The *Starling* blades are carefully crafted for an exceptional combination of hover and forward flight efficiency without swashplates. Distributed electric propulsion enables variable rotor speed to achieve high propulsive efficiency increase. In house CFD-based blade element analysis is carried out to determine optimal aerodynamic design.

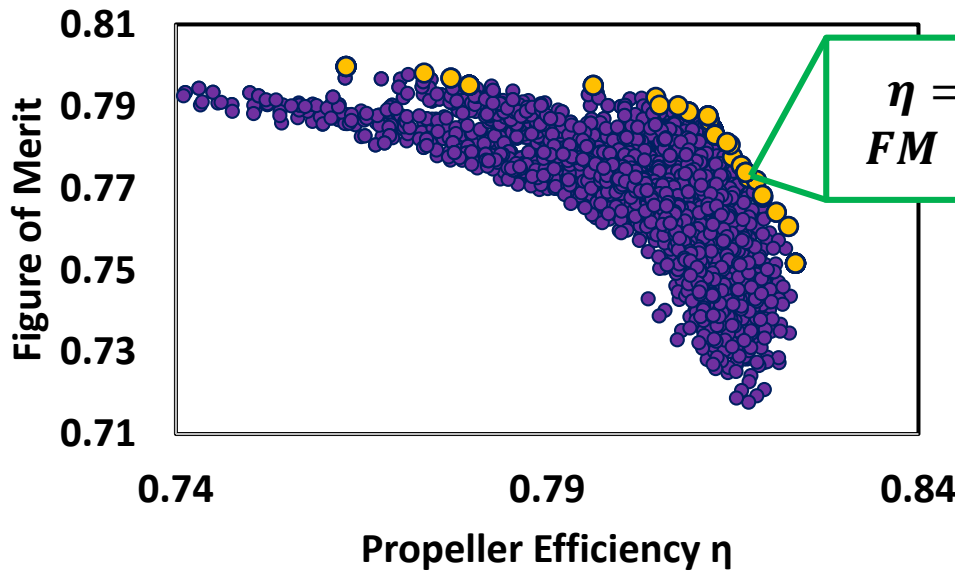
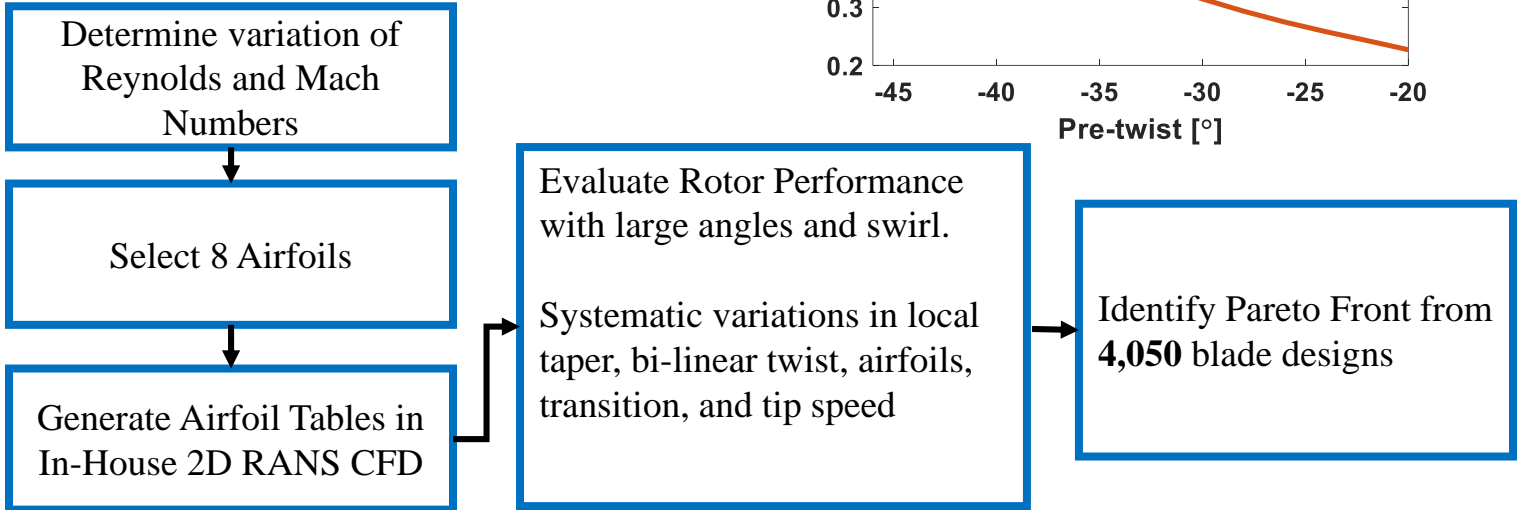
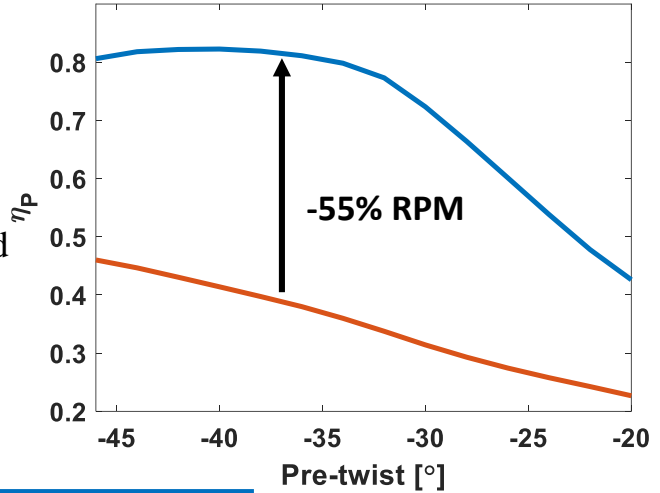

Hover RPM: 507
Cruise RPM: 225

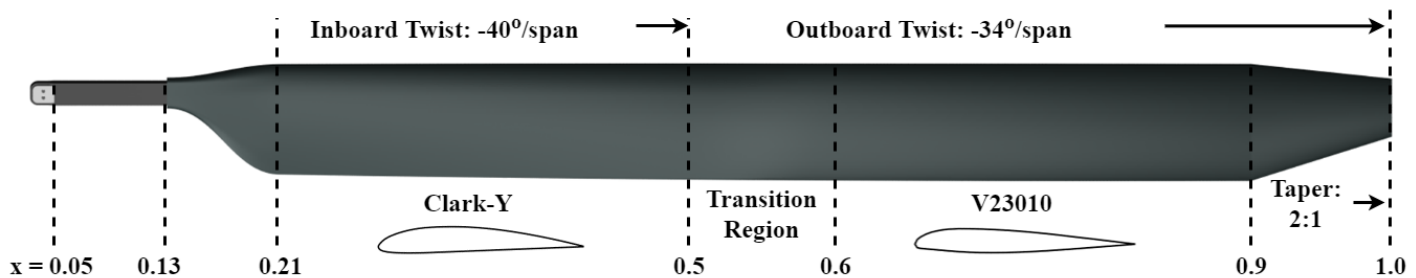



Hub Design

Hingeless hub and **simple** swashplate for **compact** nacelle

Only collective control needed with four rotors

*pylon skin removed

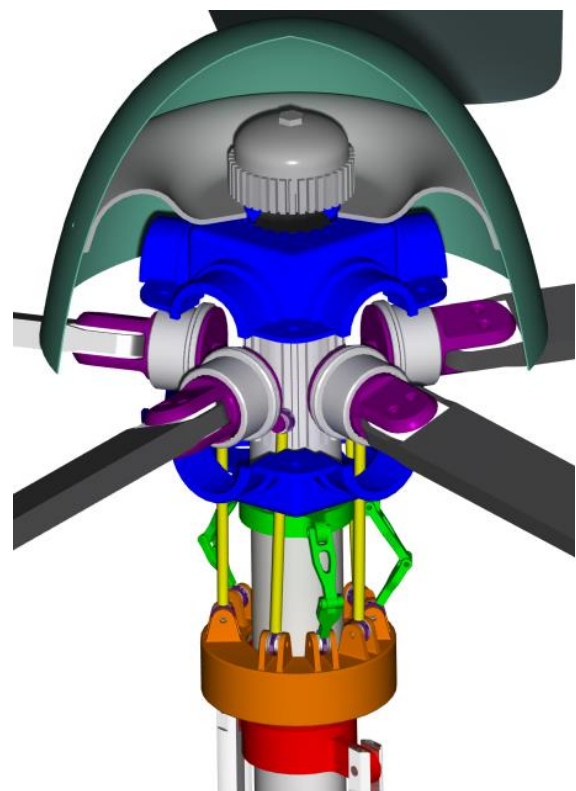
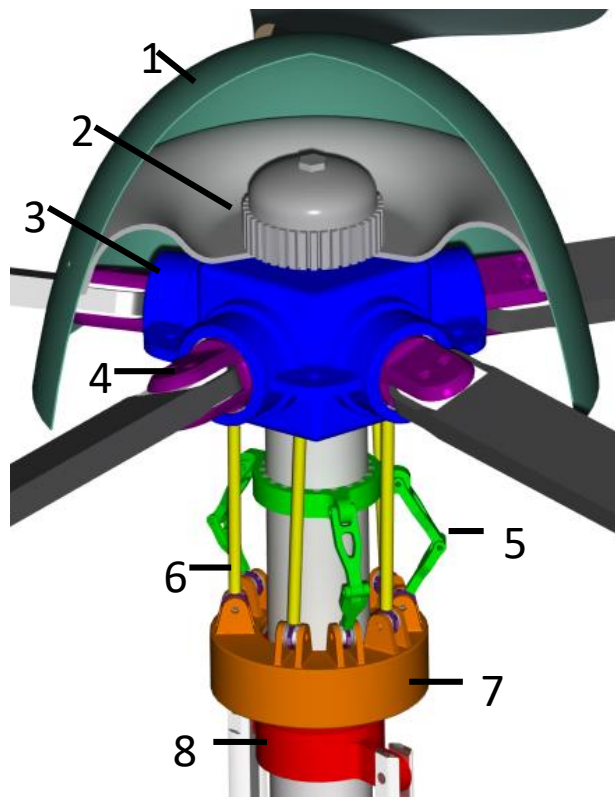

- 1. **Spinner**
- 2. **Mast Retention Nut + Spinner Mount**
- 3. **Titanium Hub + Bearing Housing**
- 4. **Titanium Blade Grip**

- 5. **Rotating Scissor Links**
- 6. **Pitch Links**
- 7. **Rotating Swashplate**
- 8. **Non-rotating swashplate**

- **Stiff in flap** reduces blade flapping
- **Soft in lag** reduces chordwise load
- 65° collective range

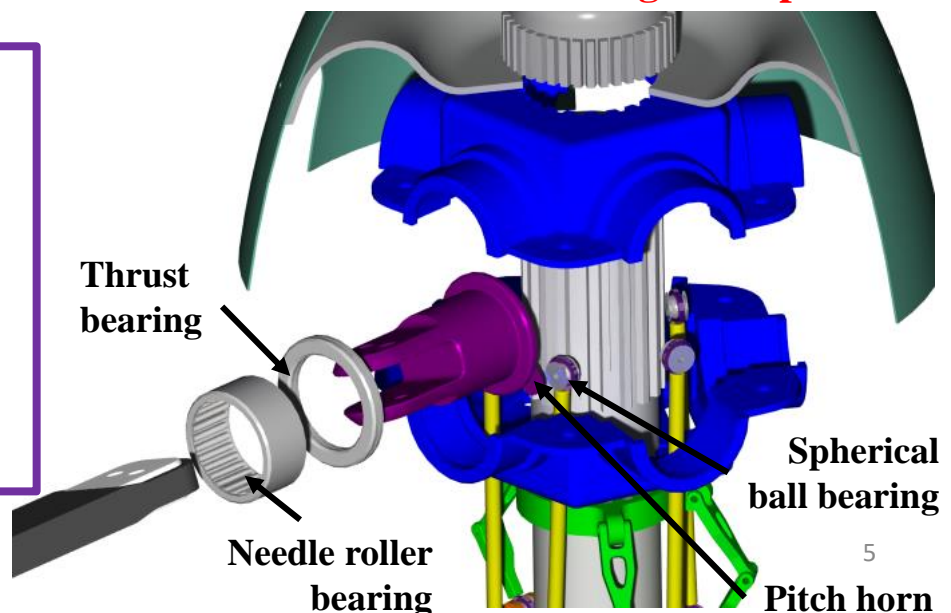

Blade Structural Design

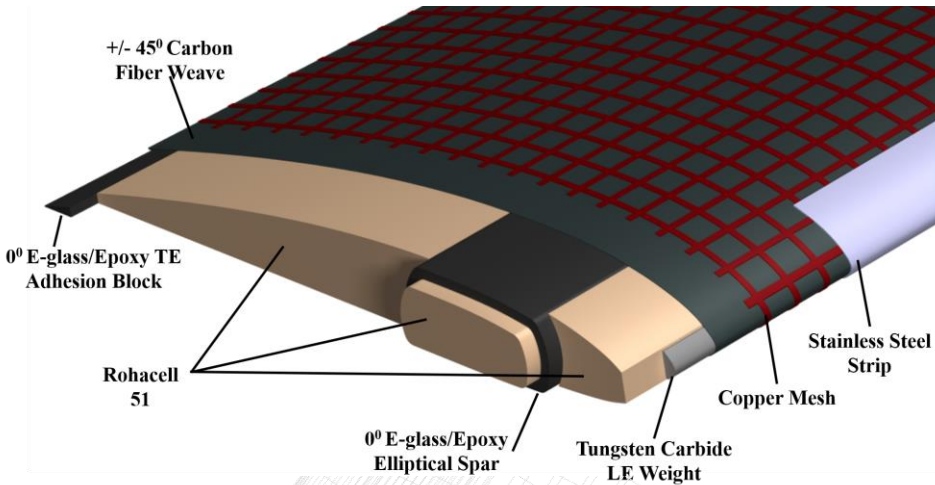

E-Glass spar for **high fatigue life**

Carbon Fiber skin for **high torsional stiffness**

Composite fiber wrapped root insert for load transfer

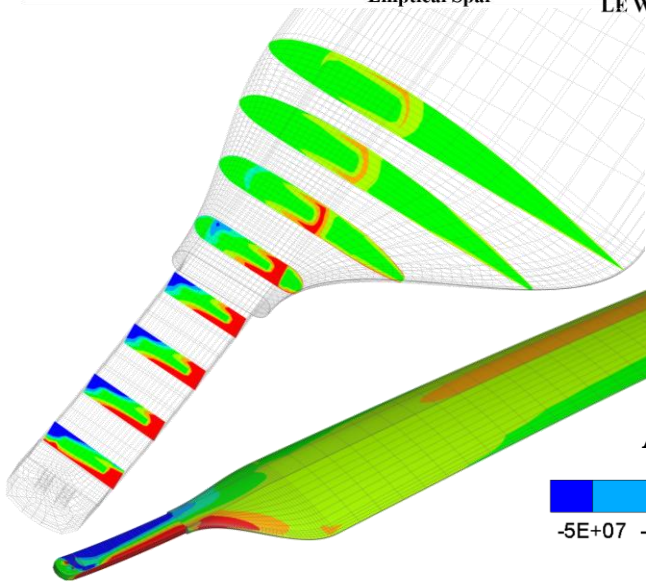

$\mu = 0.3$
FS = 1.6

Full 3-D aeroelastic stresses in rotating frame under oscillatory loading (pure edgewise)

Axial Stresses [Pa]



Hover: $\theta_{75} = 13.5^\circ$, RPM = 507

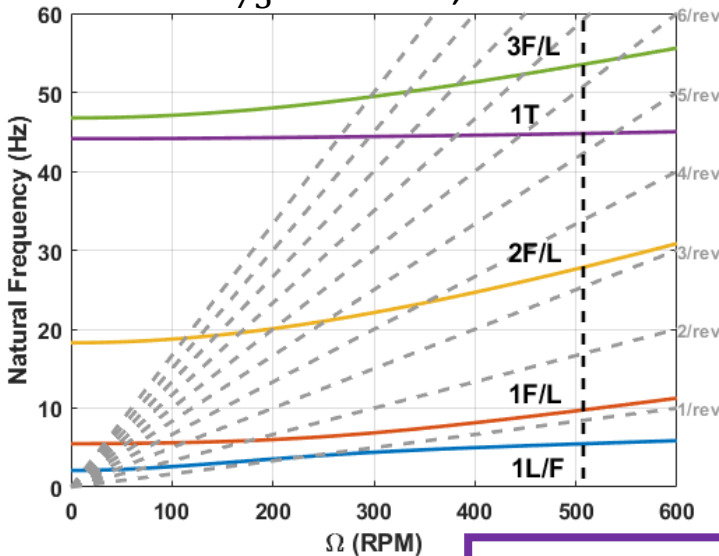

Flap: 1.15
Lag: 0.65

Cruise: $\theta_{75} = 54.1^\circ$, RPM = 225

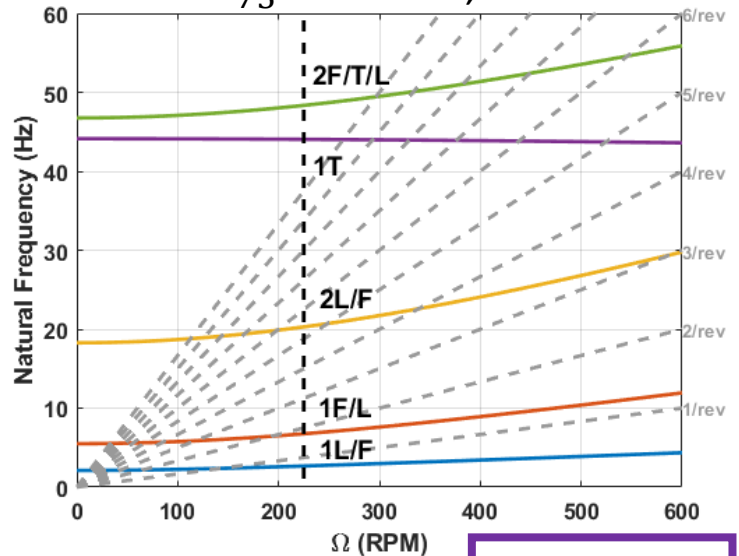

Flap: 1.8
Lag: 0.71

Power Transmission

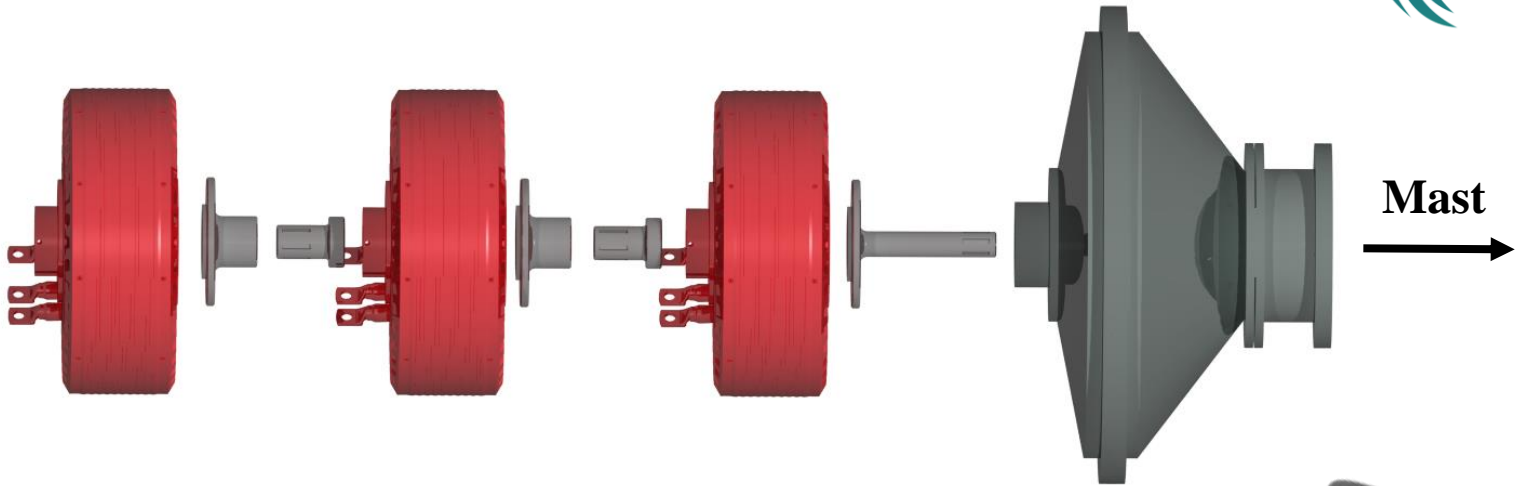

- **Three** stacked motors **per rotor**
- **Fail-safe** motor design allows loss of one motor per rotor with **no impact** on functionality
- Motor **weight minimized**
- **94%-95%** motor efficiency
- **Compact** 7.9:1 planetary reduction **reduces nacelle diameter and drag**
- 225 mm (8.85 in) nacelle radius for minimum hub drag

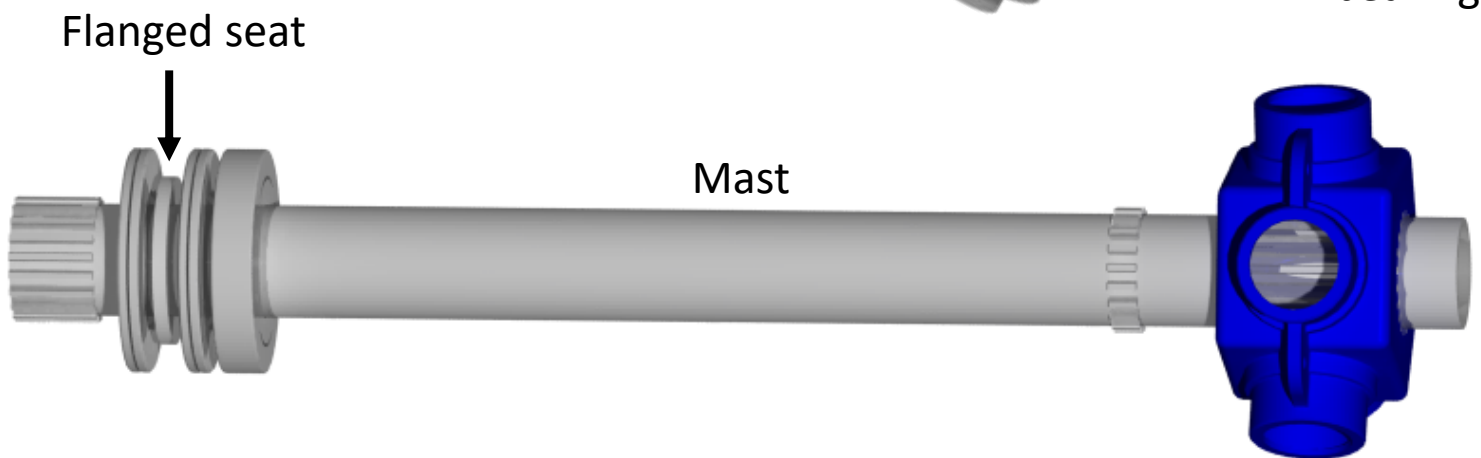
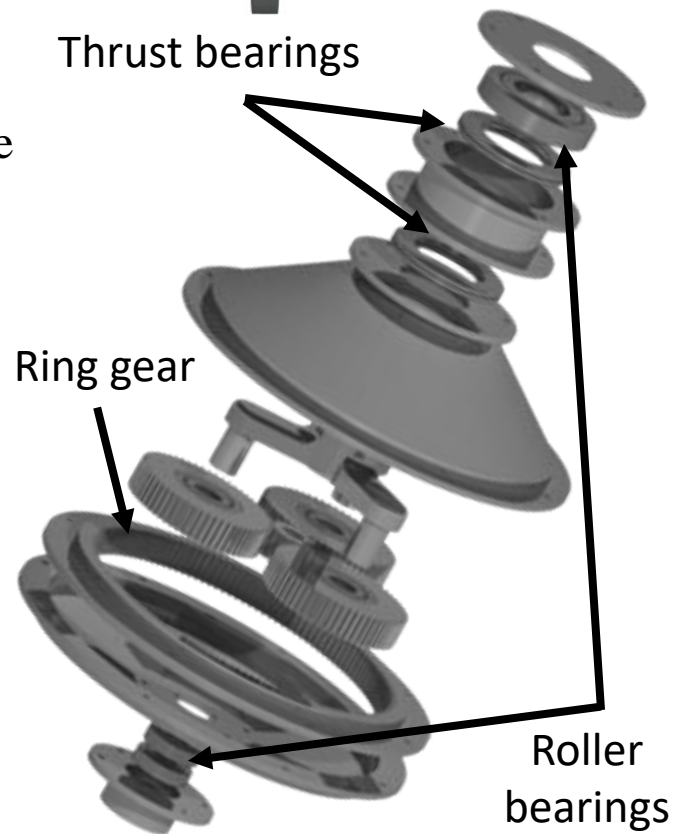

Torque evenly transferred to top and bottom housing

Nacelle and Pylon Tilting Mechanism

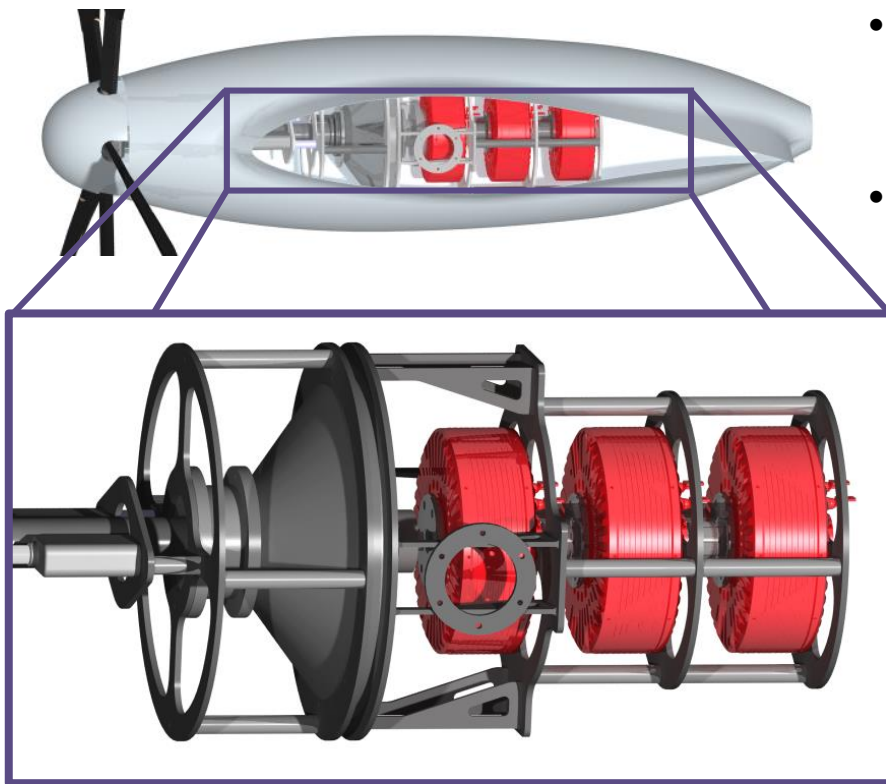

- Smooth skin transition to wing tip airfoil
- Pylon C.G. placed 56 mm (2.2 in) 2% R behind hub

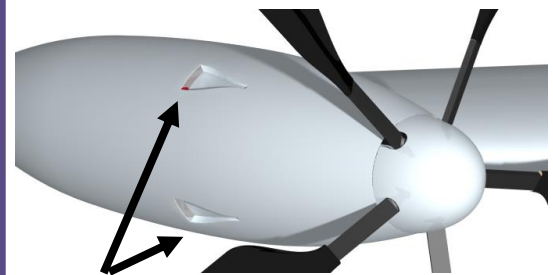

NACA ducts direct airflow for motor cooling

- **Innovative pylon tilting mechanism**
- UMD modified Bell patented technology
- Fitted within wingbox without compromising wing structure

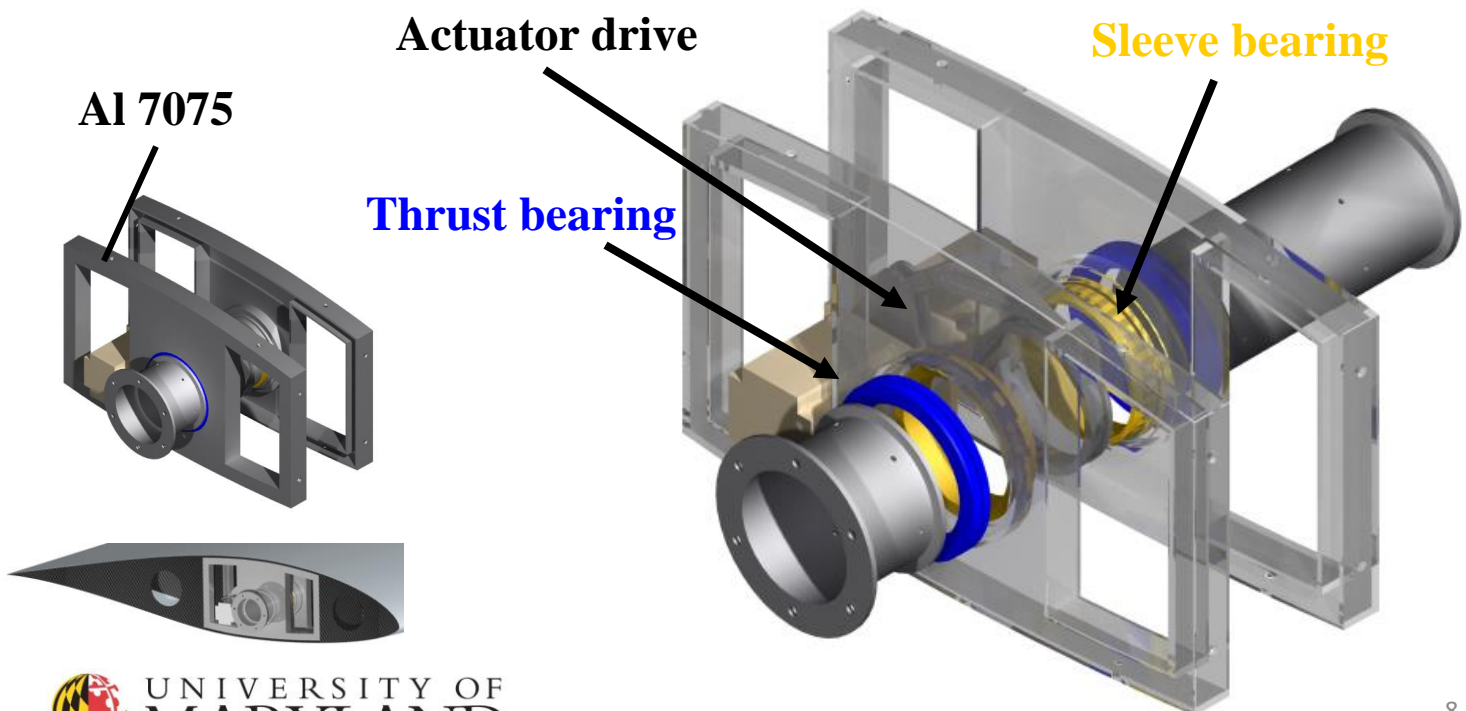



Fault Tolerant Power Transmission

Fast charge 18650 Lithium-Ion battery modules
 3C continuous discharge
 480-680V DC Bus

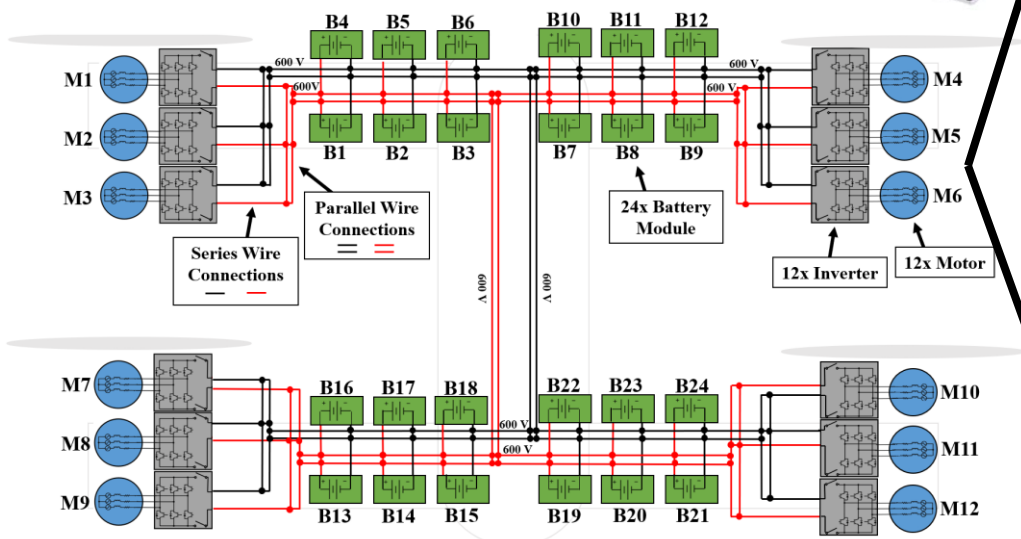
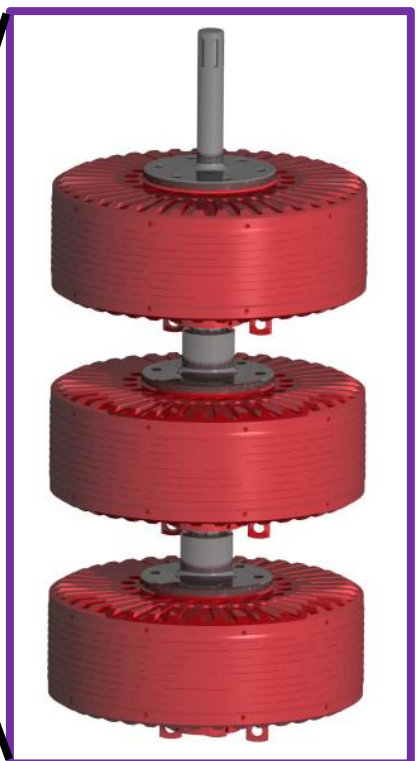
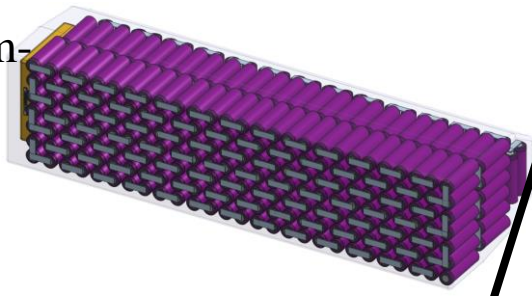

- Redundant systems for **continued safe flight** in failure scenario:
- 3 motors per rotor
 - 24 battery modules
 - Redundant actuation
 - Fly-by-wire architecture
 - Parallel wiring
 - Structurally integrated

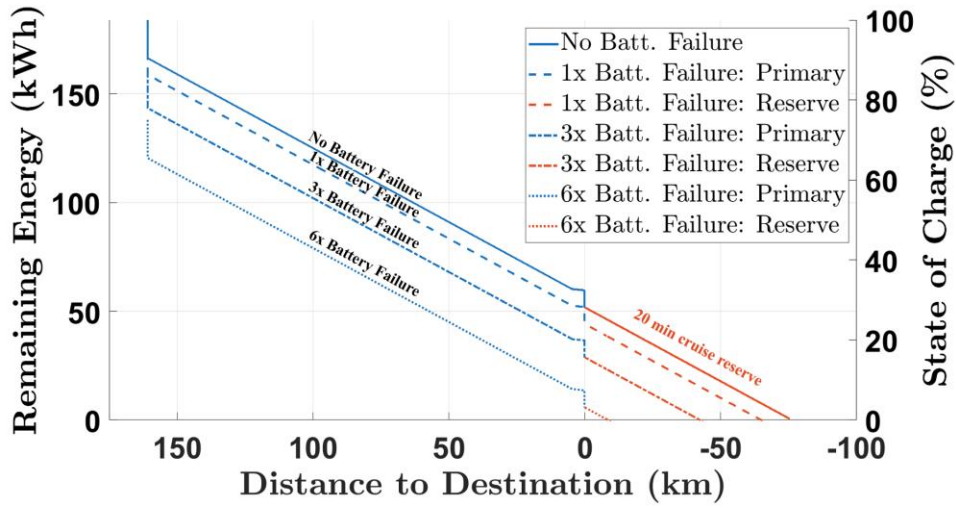

Can even lose one motor per rotor and **maintain full vehicle capability** in each mission segment

Wing Aerodynamic Design



Distributed Thrust and Lift:

The *Starling* wings are designed for optimal wing share for transition and cruise. With identical planform areas, the wings share the lift equally, 50/50.

- **Low wing loading** to maximize L/D at cruise speed
- **NACA 2418** selected for **low pitching moment** and **high C_l/C_d**
- Slightly cambered to generate lift at $\alpha < 0^\circ$ (allowing for body pitch nose down)
- **5° dihedral** added to **rear wing** for natural roll stability
- Split flaps for precise control in cruise

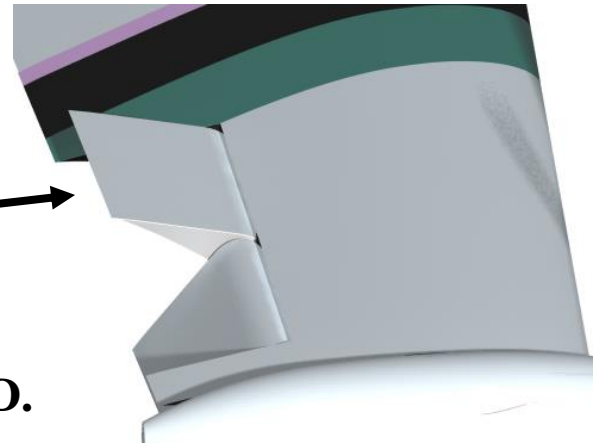

Loss of dynamic pressure on rear wing is predicted with **high fidelity 3D RANS CFD**.

Front Wing: 0° Incidence

Aft Wing: 2.50° Incidence

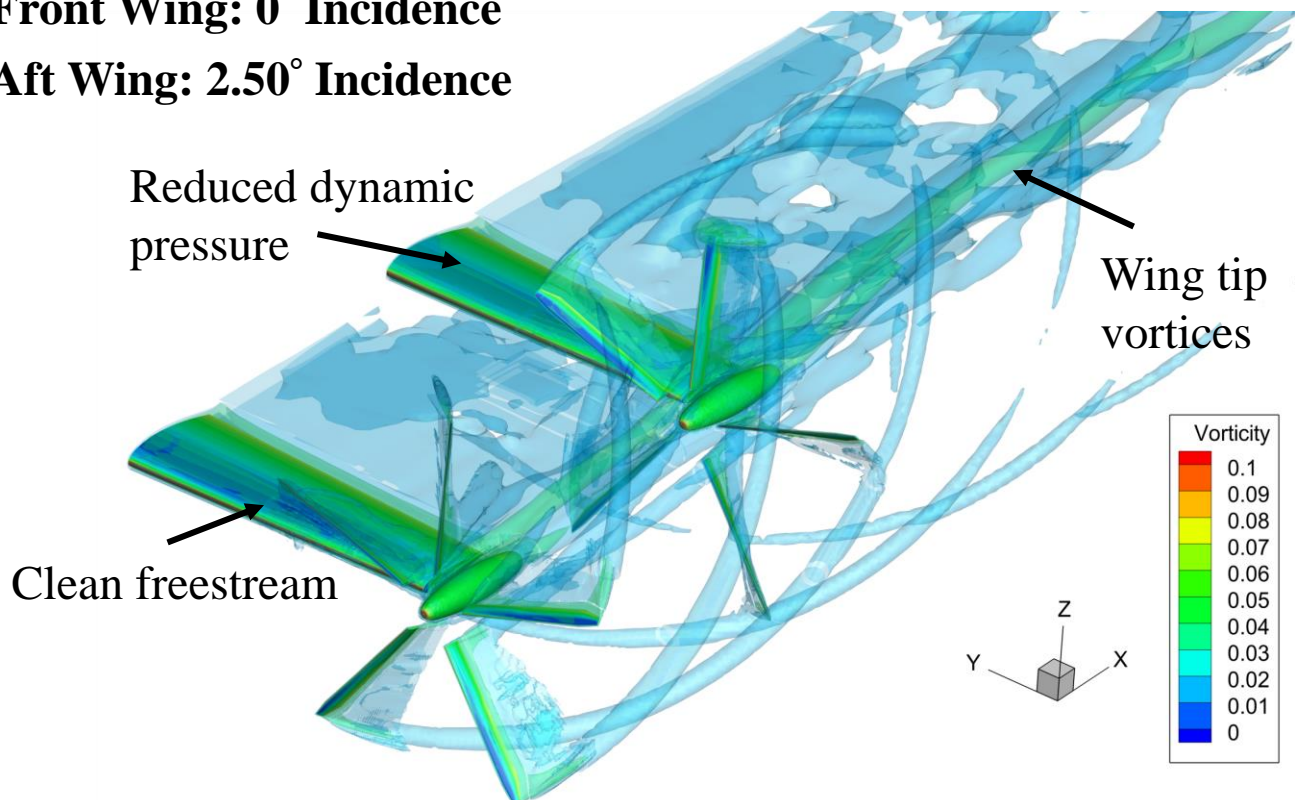

Wing Structural Design



The wing structures are designed to satisfy 14 CFR 25.337. A single torque box design provides structural and manufacturing simplicity with high torsional stiffness. A total of 26 plies of carbon fiber provide stiffness in wing beamwise, chordwise, and torsion to **prevent aeroelastic instabilities up to 315 km/hr (170 kts)**

- 18% t/c thin wings
- Designed for minimum loading at fuselage bulkheads
- Supports integrated battery storage

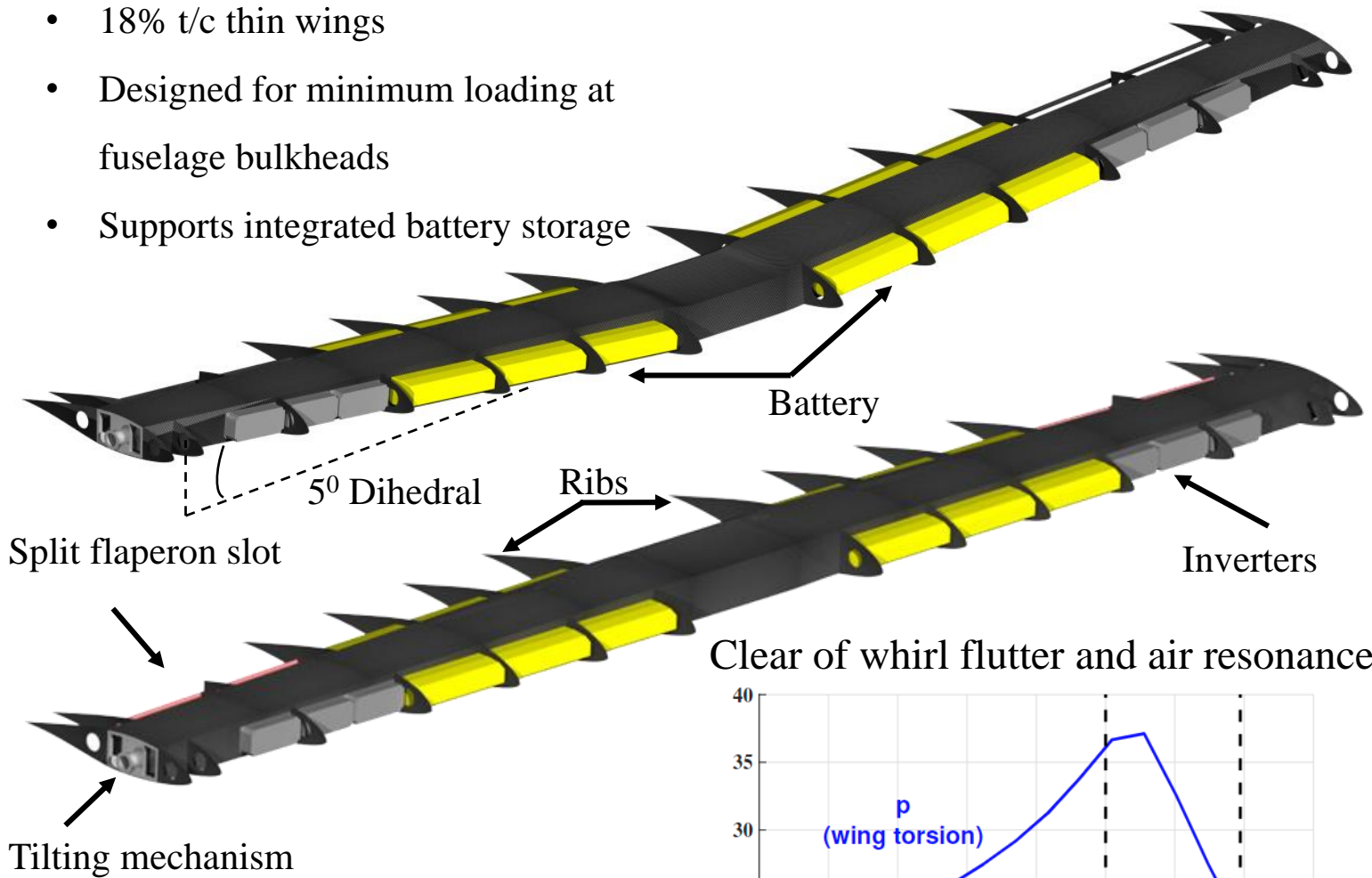

The wings house all the main electrical power and power distribution components, separating them from passengers

Clear of whirl flutter and air resonance

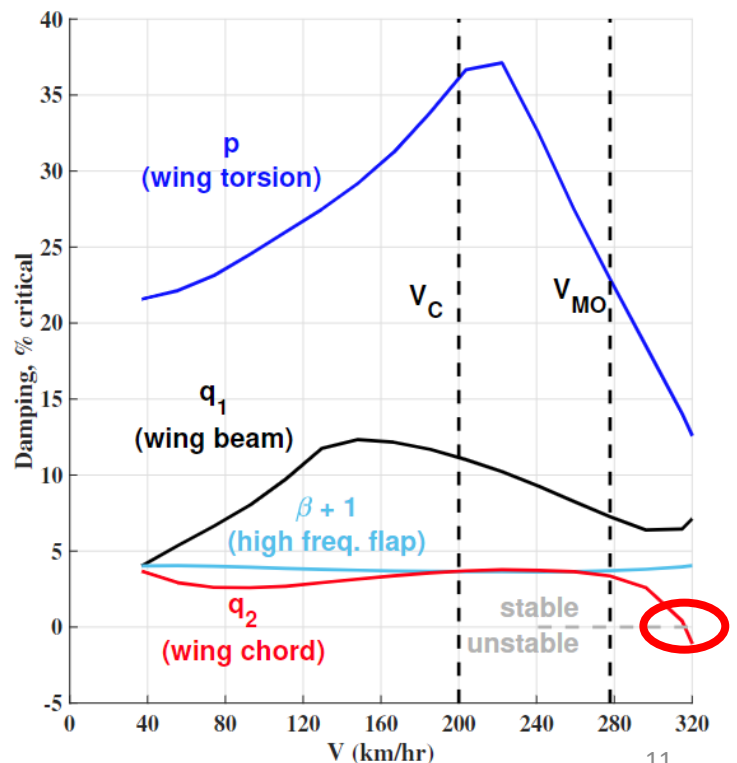

Airframe & Landing Gear Design



The *Starling* airframe is designed to be slender and is sized for limit loading conditions in accordance with 14 CFR 29.341 and 25.241. High fidelity FEA was carried out on the most highly loaded members of the airframe: the bulkheads securing the wing to the fuselage.

Special torque box and bulkhead for large sliding doors for special needs passengers

Symmetric pull-up load case

Wing torque box is fastened to structure by rivets

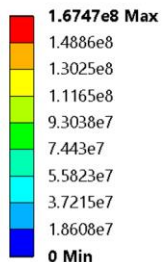

Structure has a factor of safety of 1.672

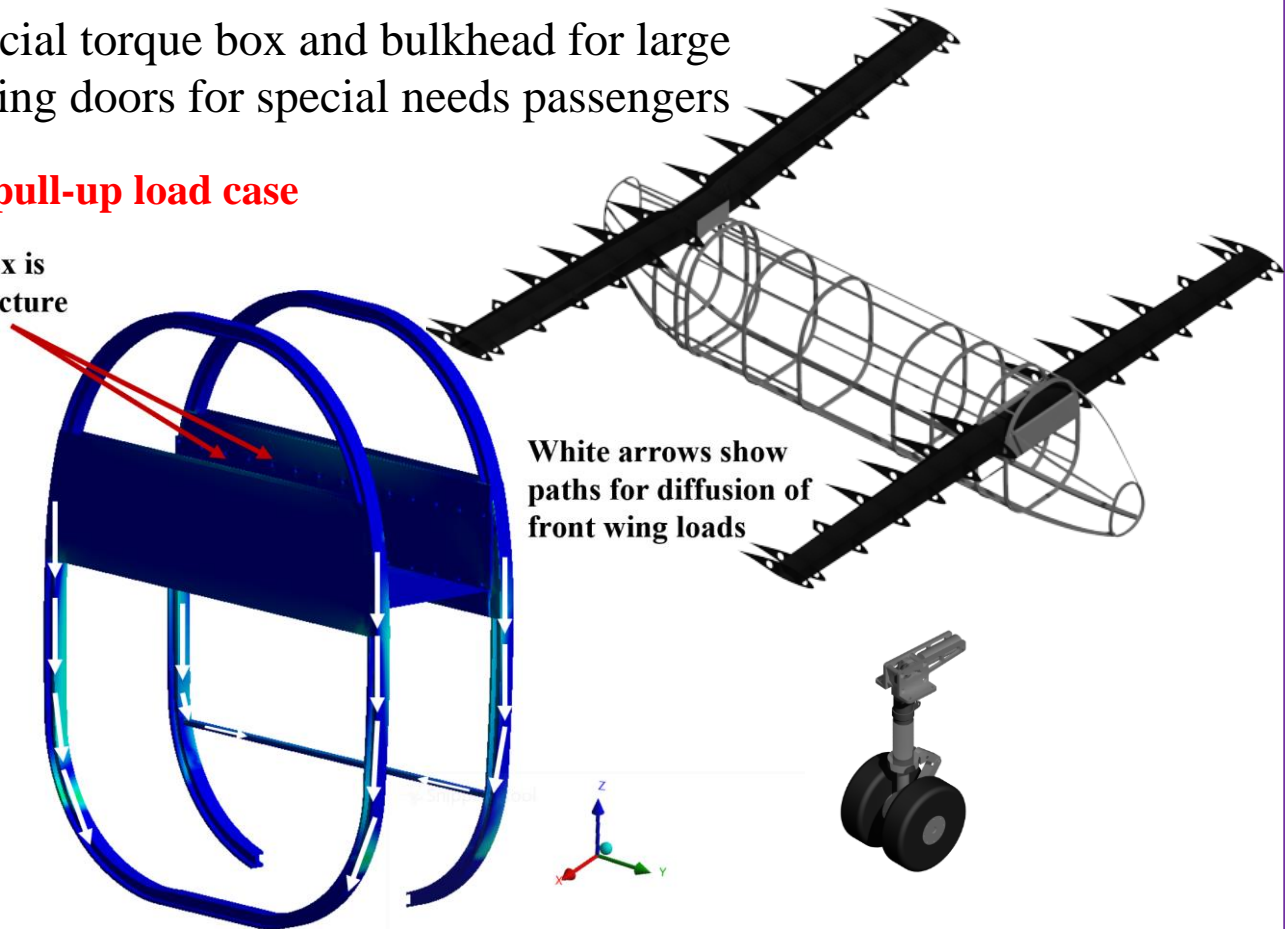

- Retractable landing gear to minimize drag in cruise
- Oleo struts sized to 2 m/s (6.55 ft/s) drop velocity

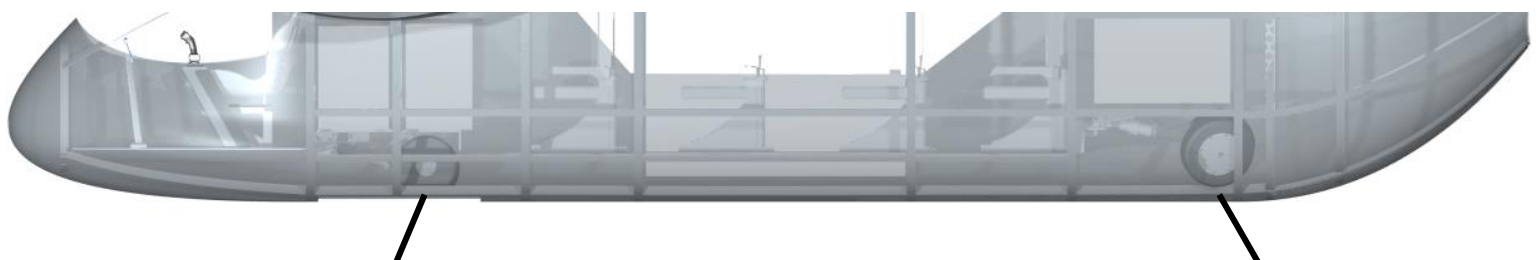

Nose landing gear

Aft landing gear

Avionics & Flight Controls



Starling features **state-of-the-art**, innovative flight control systems and avionics technology catered to reduce pilot workload and provide excellent field of vision:

- Triple redundant Stability Augmentation System (SAS)
- Four-axis Automatic Flight Control System (AFCS)
- Flight Management System (FMS)
- IMX490 automated vision sensors for fiducial landing
- Triple redundant electrically heated pitot-static tubes
- Inertial measurement units (IMU)
- Contoured, reflection resistant windows

Intuitive Unified pilot control system removes the pilot from stabilization process, allowing full focus on the mission and reducing pilot induced errors.

GNSS free landing capability with fiducial and feature-based autonomy prevent jamming, spoofing and other cyber threats

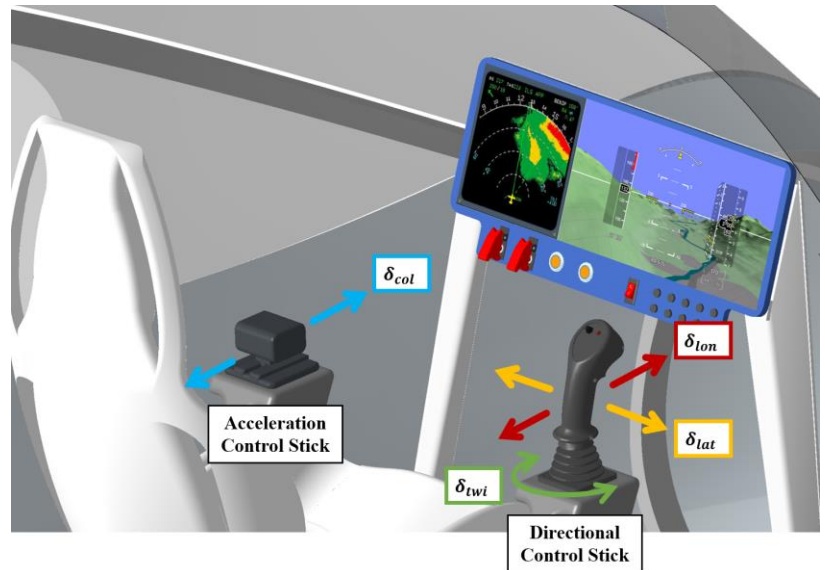

Hover Control Mixing

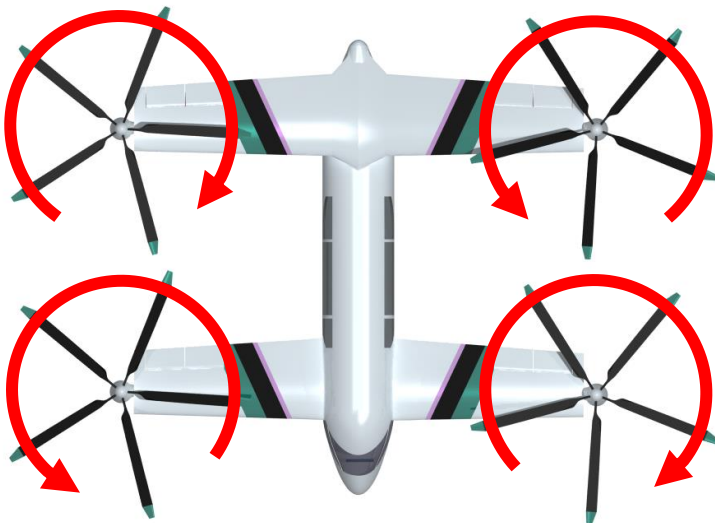

Direction of rotation

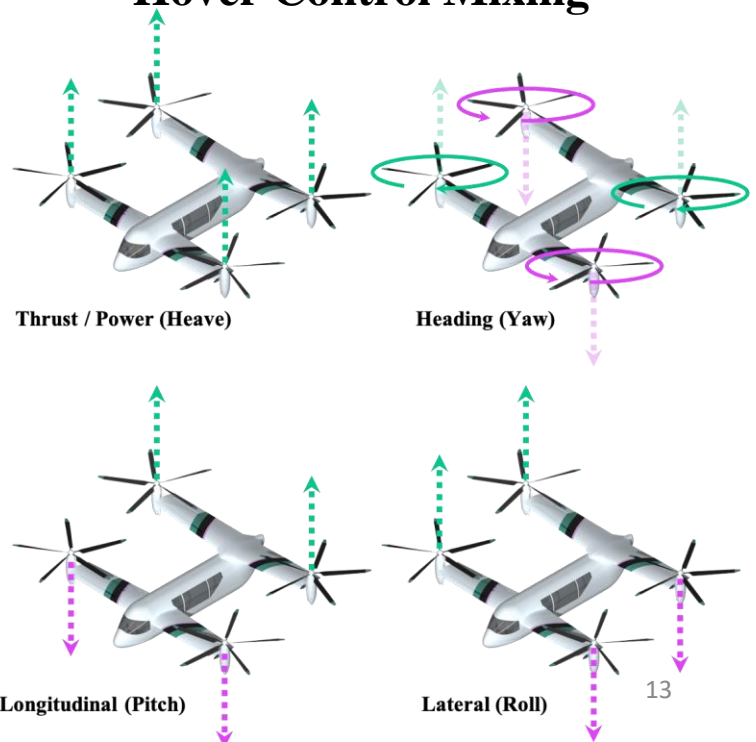

Acoustics



Specially tailored to blend in to urban environments, the *Starling* maximum noise generated in hover at 91 m (300 ft AGL), from an observer is **only 52.2 dBA**, under the noise threshold of a conversation (60 dBA) 1m (3 ft) away. City traffic ranges on the scale of **70-80 dBA**, making the *Starling* barely noticeable as it enters and exits the skyline. The *Starling* signature is so low it is barely noticeable in a suburban residential neighborhood at the same distance.

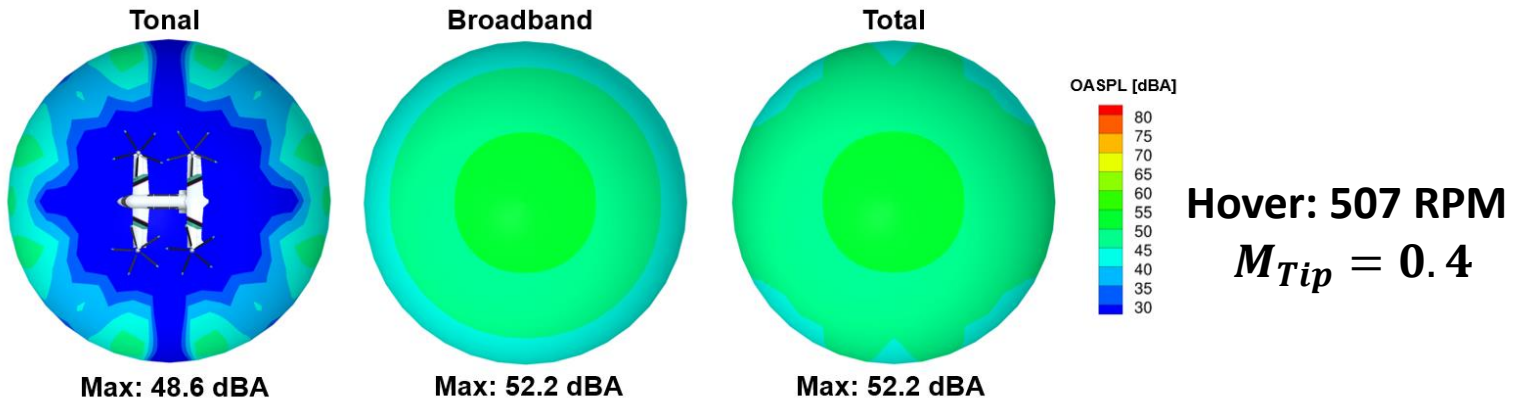

Acoustics considered at the early stages of conceptual design:

- **Low tip speed:** 137 m/s (450 ft/s)
- Odd number of blades
- $M_{Tip} = 0.4$
- Higher number of blades: 5
- Distributed thrust: 4 rotors
- Hingeless hub avoid δ_3

Noise around cabin in **cruise**

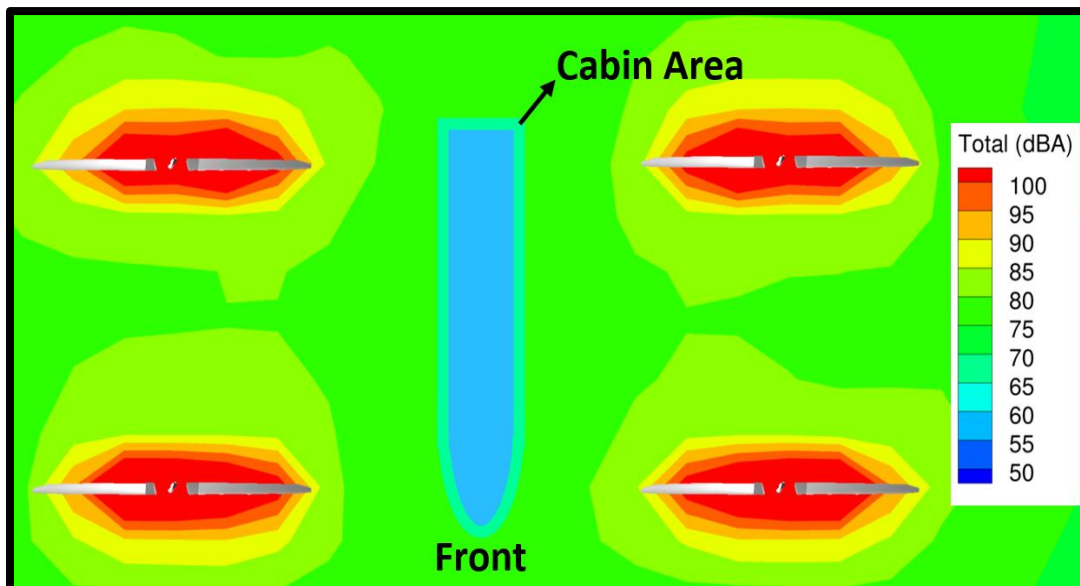

Sound pressure reducing material lines the fuselage for a **quiet, comfortable ride.**



Performance

Unprecedented hover and cruise performance for all-electric VTOL. Low disk loading, high power loading, high Figure of Merit. Variable speed prop-rotor enables high cruise L/D, significantly reducing power required.

Helicopter Mode:

- DL = 32.9 kg/m² (6.74 lb/ft²)
- PL = 5.94 kg/kW (9.77 lb/hp)

Airplane Mode:

- **Max L/D = 10**
- **137 kW cruise power**
- Cruise ROC = 7.58 m/s (24.9 ft/s)
- Hover ROC = 15.45 m/s (50.7 ft/s)

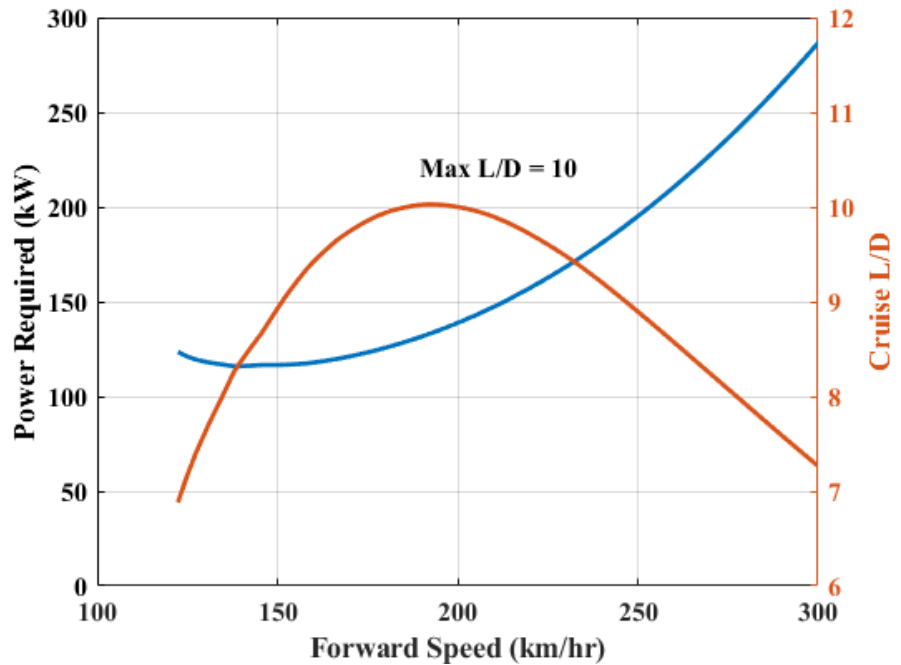

Performance enhancements:

- Rounded fuselage nose to reduce drag (-6.7%) and downforce (-13.6%)
- Large flaperons to reduce download in hover
- Blended **compact** nacelles into wing for decreased interference drag
- Total flat plate area in cruise = 0.64 m² (6.88 ft²)
- Thinner wings enabled by hingeless rotors

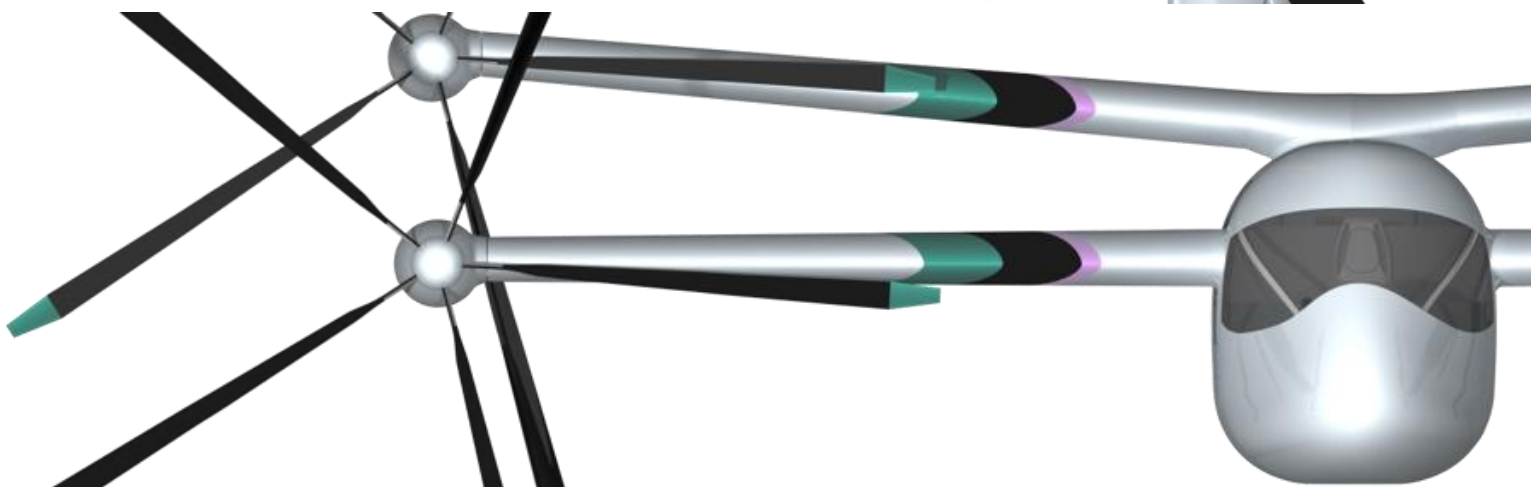
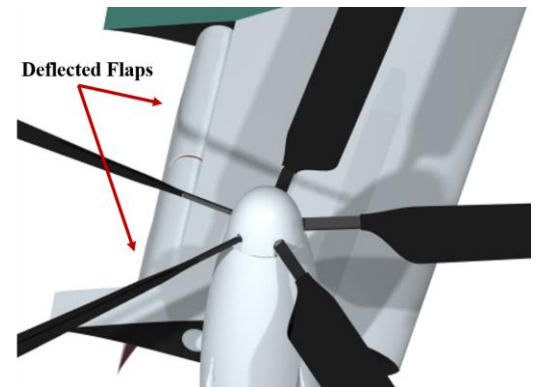



Transition

The *Starling* is designed for precision maneuver within the city and transition away to an airplane for high efficiency climb and cruise. Transition can occur at lower speeds because of the large wing area, providing low stall speed. This reduces the power earlier in the mission and extends the vehicle's range and reserve for safety.

- Rotors and wings share lift in transition

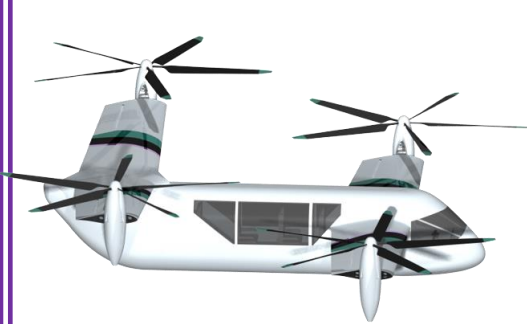

$V = 0 \text{ km/hr}$

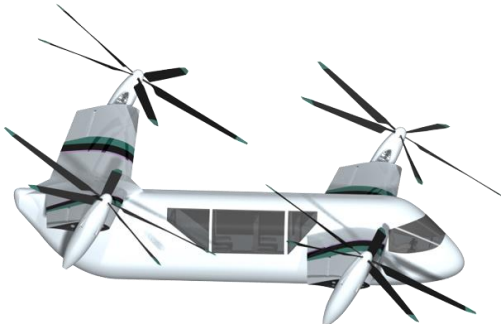

$V = 135 \text{ km/hr}$

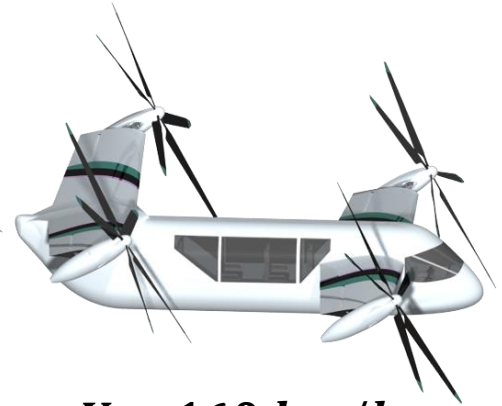

$V = 160 \text{ km/hr}$

- Safe ground clearance up to 40° pylon angle (cruise 0°)
- Pylons **transition** from helicopter to airplane mode in **20s** avoiding prolonged loading at high advance ratios
- RPM reduced quickly at the end of pylon transition to bypass high loading at per rev crossings

Climb as an airplane

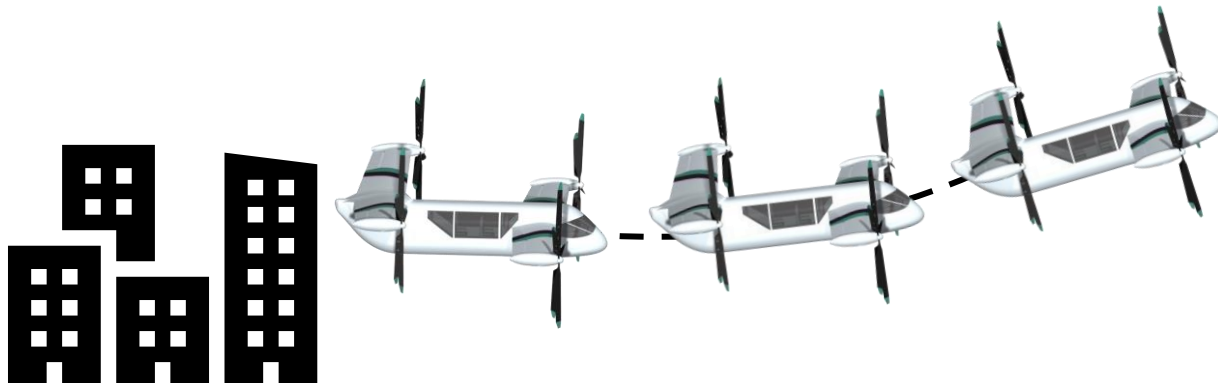

Universal Interior Design



Intelligently crafted for **accessibility** and **equity**, universal design practices are incorporated from the ground up. The *Starling* caters to everyone and gives all passengers the ability to make the ride experience memorable.

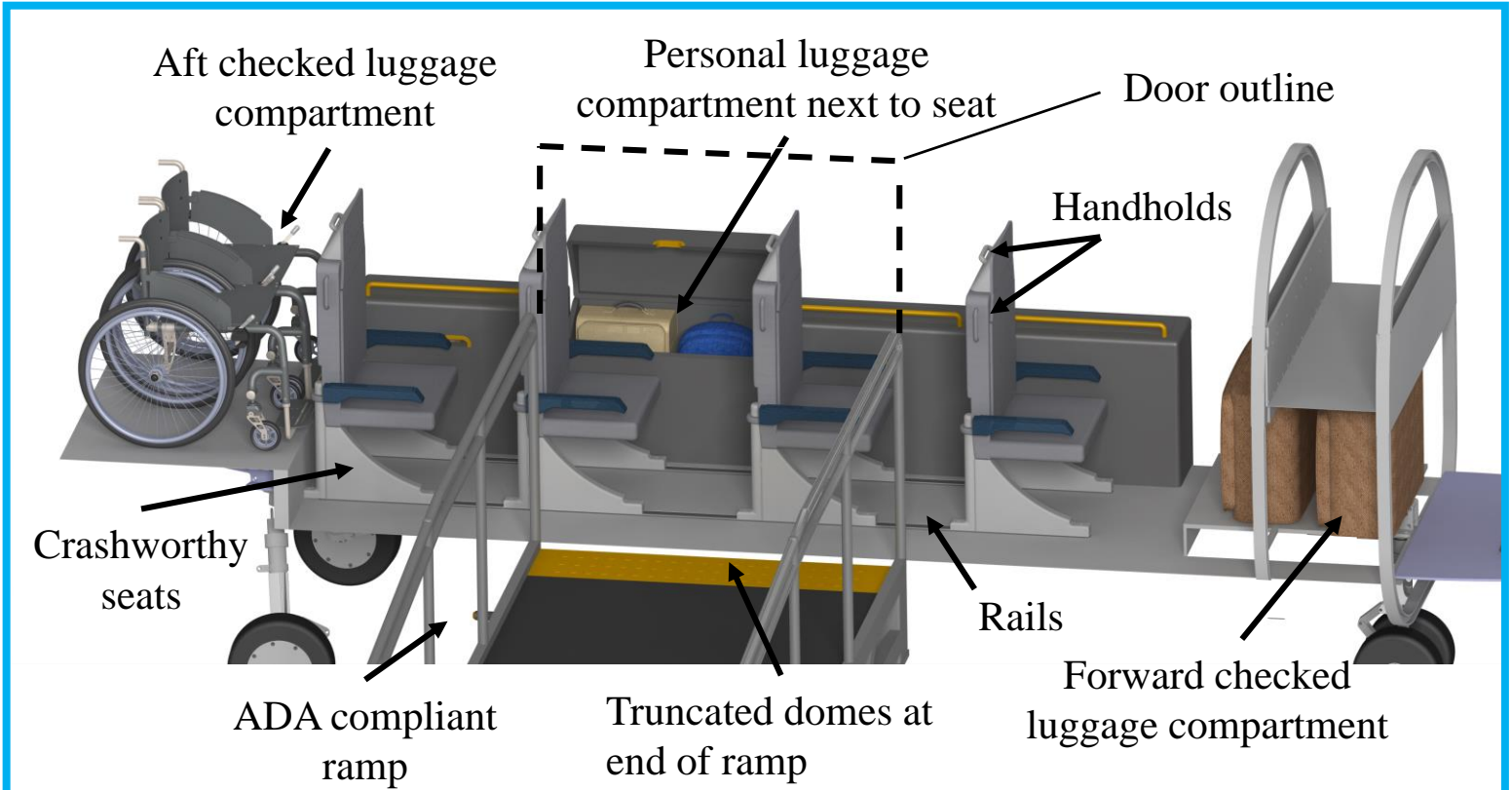

- Aft luggage compartment sized to **fit two wheelchairs as checked baggage**
- Aft luggage compartment also accommodates walkers, crutches, and other required durable medical equipment
- Two seats directly accessible from 1.52 m (5 ft) wide sliding door eases process of wheelchair transfer **without transferring into aisle chairs**
- Seats aligned on one set of rails provide high level of customization to seating arrangement
- Every seat is a window seat and an aisle seat
- Aisle space doubles as available space for a service animal
- Each seat designed to carry up to a 112 kg (246 lb) person.



Reconfigurable Cabin

The *Starling* cabin is **highly modular** and **customizable** to support any special need no matter how unique.

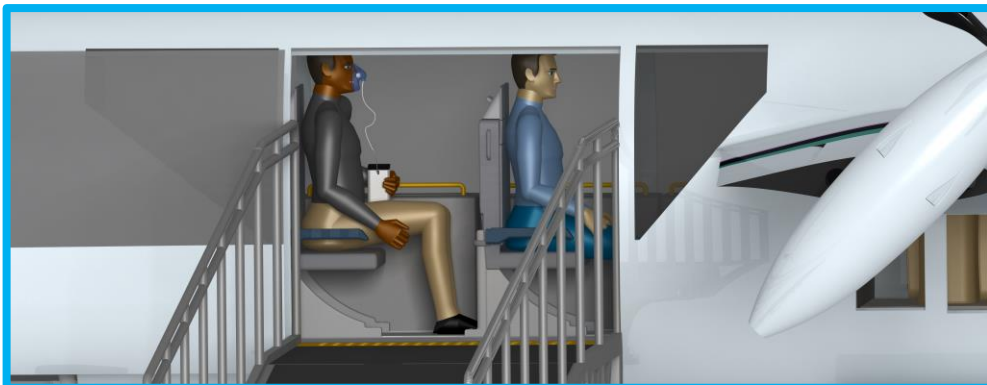
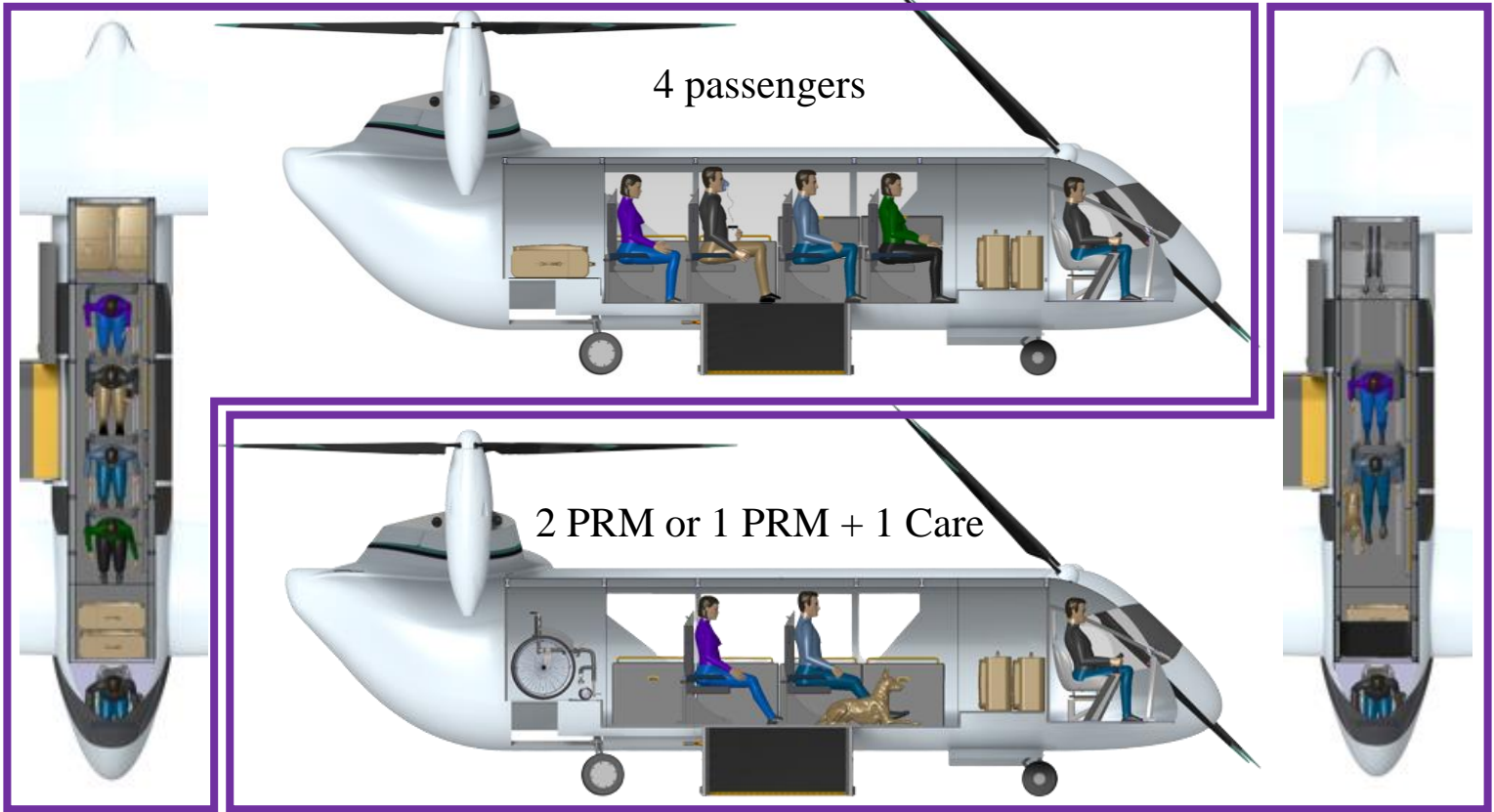

- Seats removable to provide more space to passengers with reduced mobility (PRM)
- Wide ramp and door support **simple ingress and egress** in any configuration
- Seats can be arranged back-to-back or face-to-face
- Caregiver to face client



Safety Driven Design

High wing keeps rotors away from passengers

Rotors canted when boarding to clear from passengers

Low disk loading reduces downwash increasing safety of passengers and ground personnel on landing pad

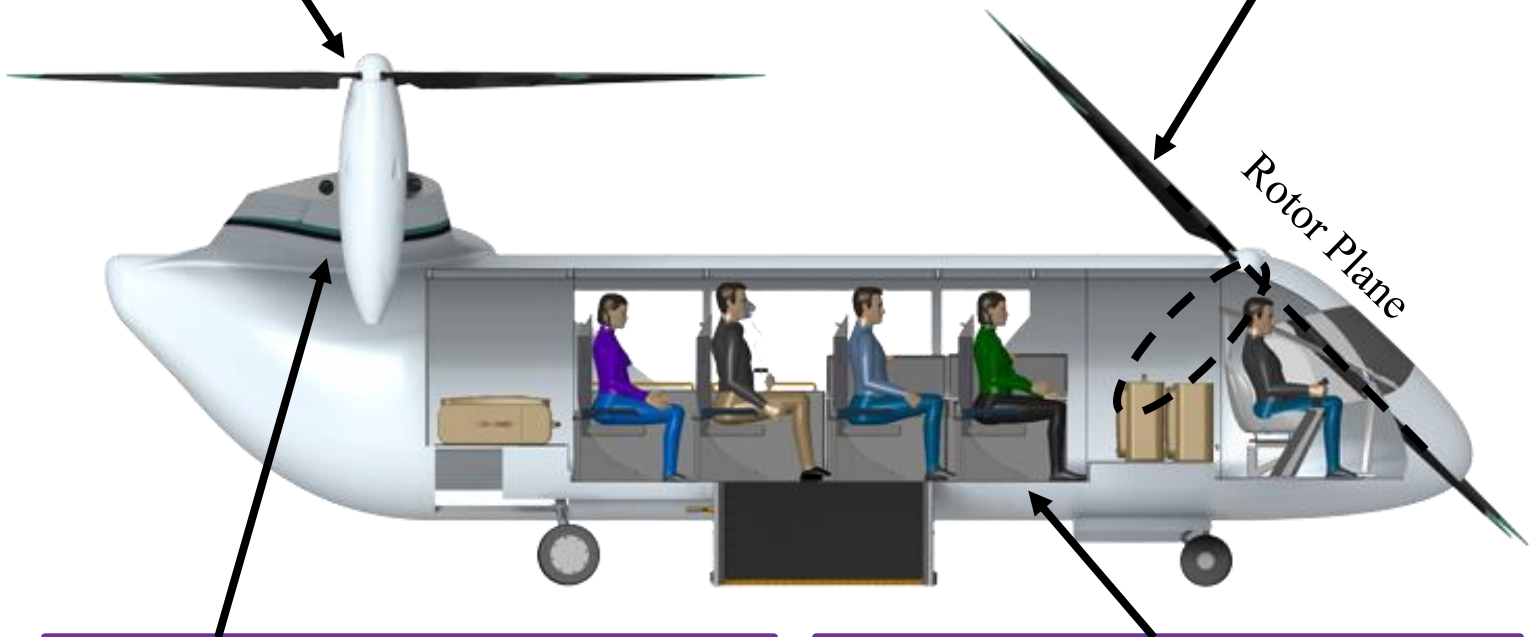

Batteries in wings separates passengers from potential hazards

Low fuselage keeps passengers close to ground when boarding

The *Starling* is tolerant to any single point of failure and in the extremely rare case control is entirely lost to all rotors, the *Starling* can glide to safety and land as an airplane with the pylons tilted 45°

Can lose one motor per rotor and still retain full vehicle capability!

- High voltage buses away from cabin
- 14 CFR 29.785 compliant crashworthy seats
- All passengers within 2 ft of exit

Summary



High payload capability

- Max 590 kg (1,300 lb)
- MGTOW of 2,518.79 kg (5,552.97 lb)
- Accommodate folding power wheelchairs

Optimized for maximum range and efficiency

- L/D = 10 @ 200 km/hr (108 kts)
- Range = 175 km (109 mi)

Good hot and high performance

- HOGE altitude of 2,400 m (7,874 ft)
- Maximum operating altitude 2,438 m (8000 ft) set by 14 CFR 25.841
- Operable in every major city in the continental U.S., Hawaii and US territories

Fast

- High speed flutter free civil transport up to 278 km/hr (150 kts)
- Mission completion in **50 min**

Affordable

- **US \$2.91 per passenger mile**
- US \$2.45 M flyaway price

Designed **exclusively** for air taxi operators, **intuitively** for airline pilots, **attentively** for all potential passengers with special needs, **mindfully** for the community, **safely** for those onboard and on the ground, and **responsibly** for the environment, the *Starling* is as unique and inclusive as the bird.

Leading the pack in payload capability

