



| **MG-76 Catacopter**

Executive Summary

Penn State Flying Lions Design Team



Nathan Brewer – Jacob Davis – Sami Grazioli – Joshua Oslon
Thomas Hydro – Timothy Nelson – Jack Scully – Peter Jurlina
Ryan Peterson – Tyler Holcomb



Introduction

The MG-76 Catacopter is an electric vertical take-off and landing (eVTOL) tandem helicopter. As an air taxi, the MG-76 Catacopter carries its passengers to their destination efficiently, traveling 100 miles in less than an hour. With accommodations for a wide range of disabilities, the MG-76 Catacopter is capable of transferring all passengers to their destination with ease.

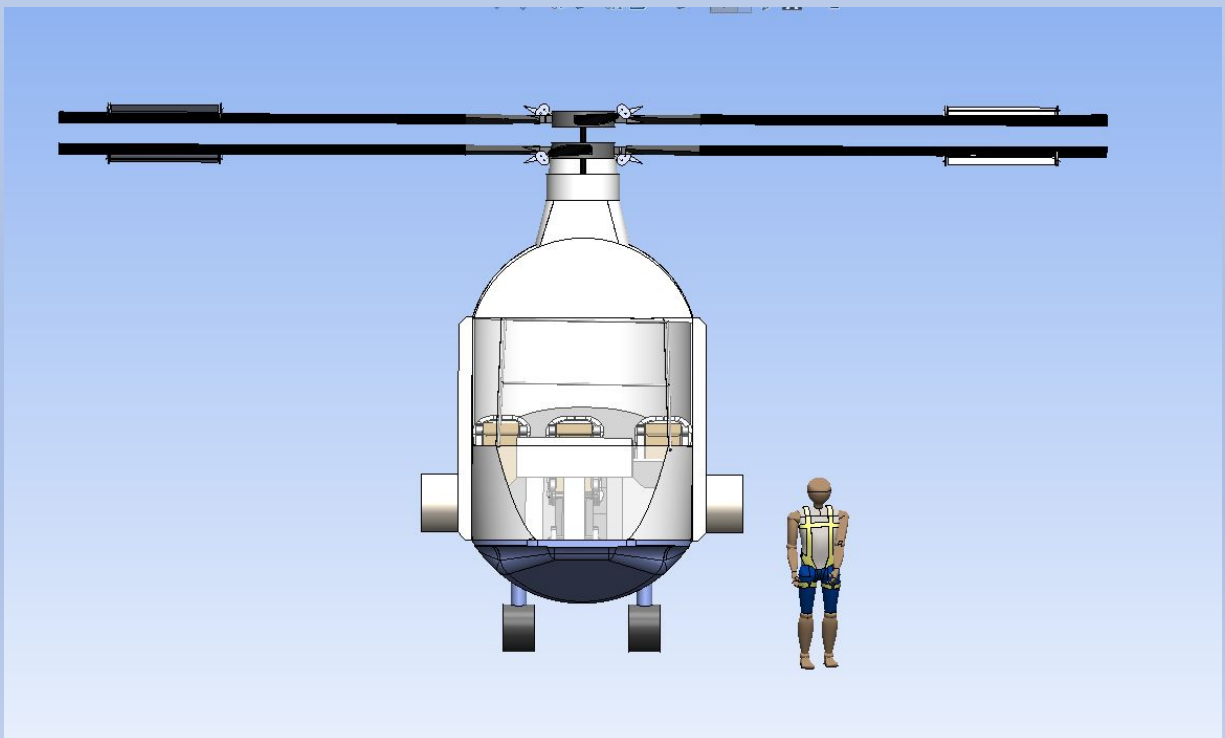

Vehicle Overview

The utilization of a tandem helicopter maximizes the available interior cabin volume. The MG-76 Catacopter is designed for a versatile and reconfigurable cabin layout to accommodate a wide range of passengers.

Gross Weight	6789 kgs (14967 lbs)
Empty Weight	6147 kgs (13551 lbs)
Cruise Speed	93kts (107 mph)
Climb Speed	72kts (83 mph)
Passenger Layout	4 without Disabilities 2 with Disabilities

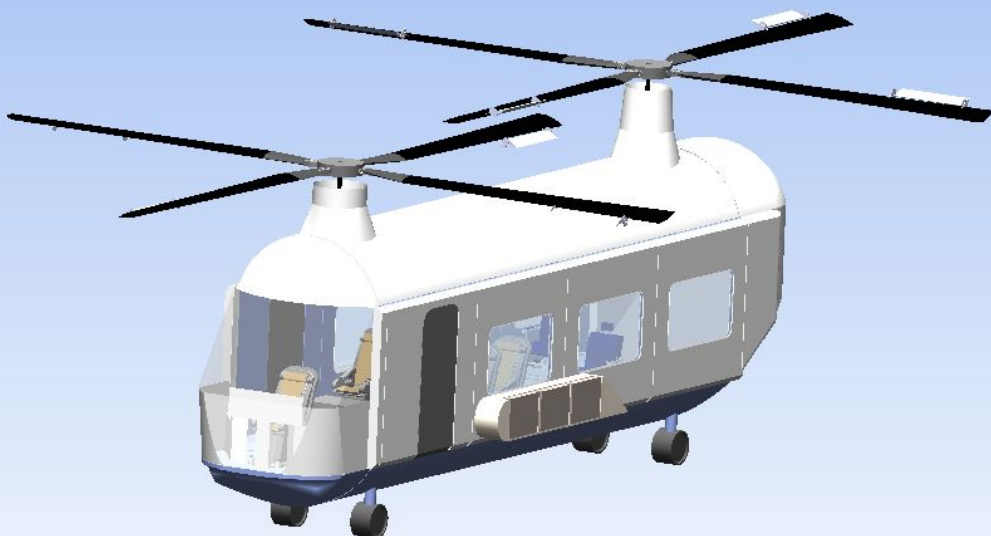



Available Accommodations

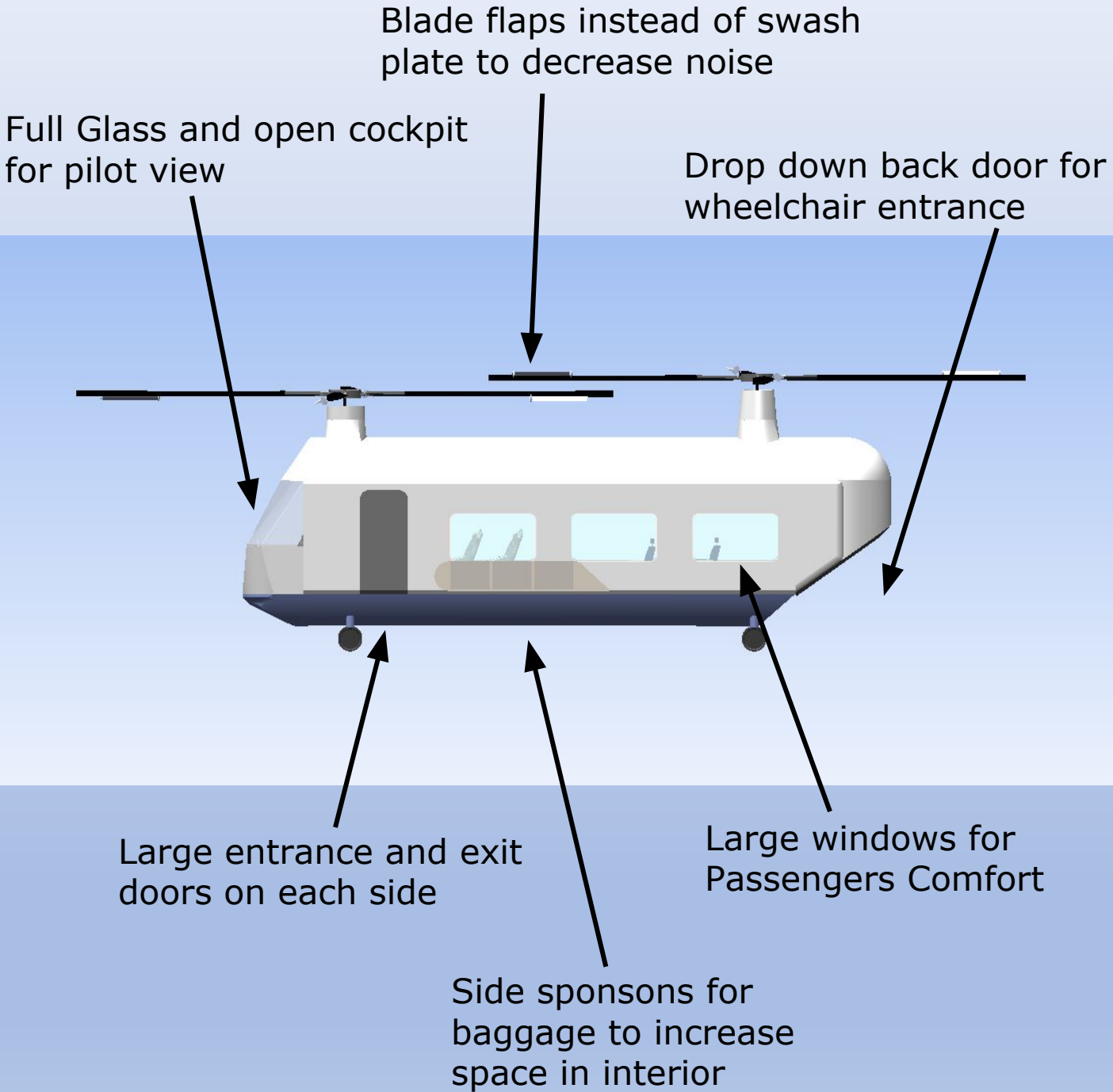



3D Sketches

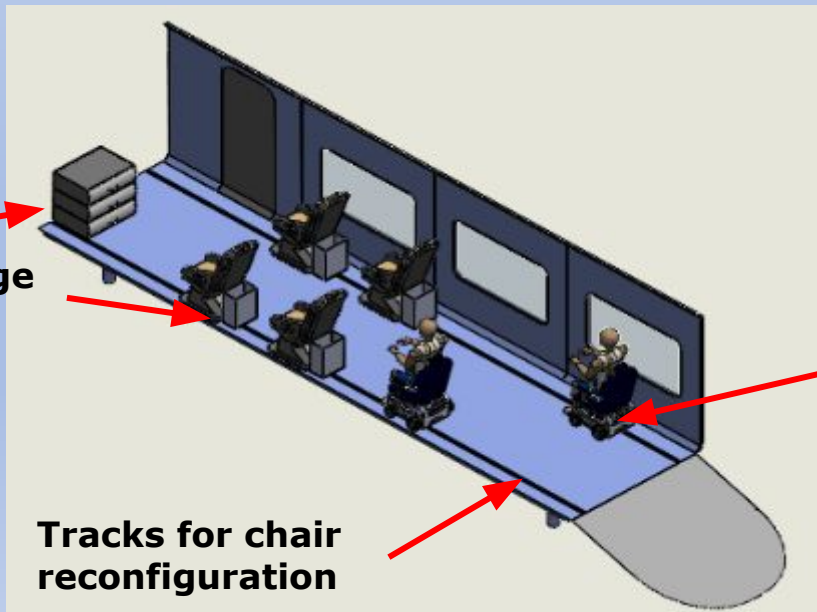
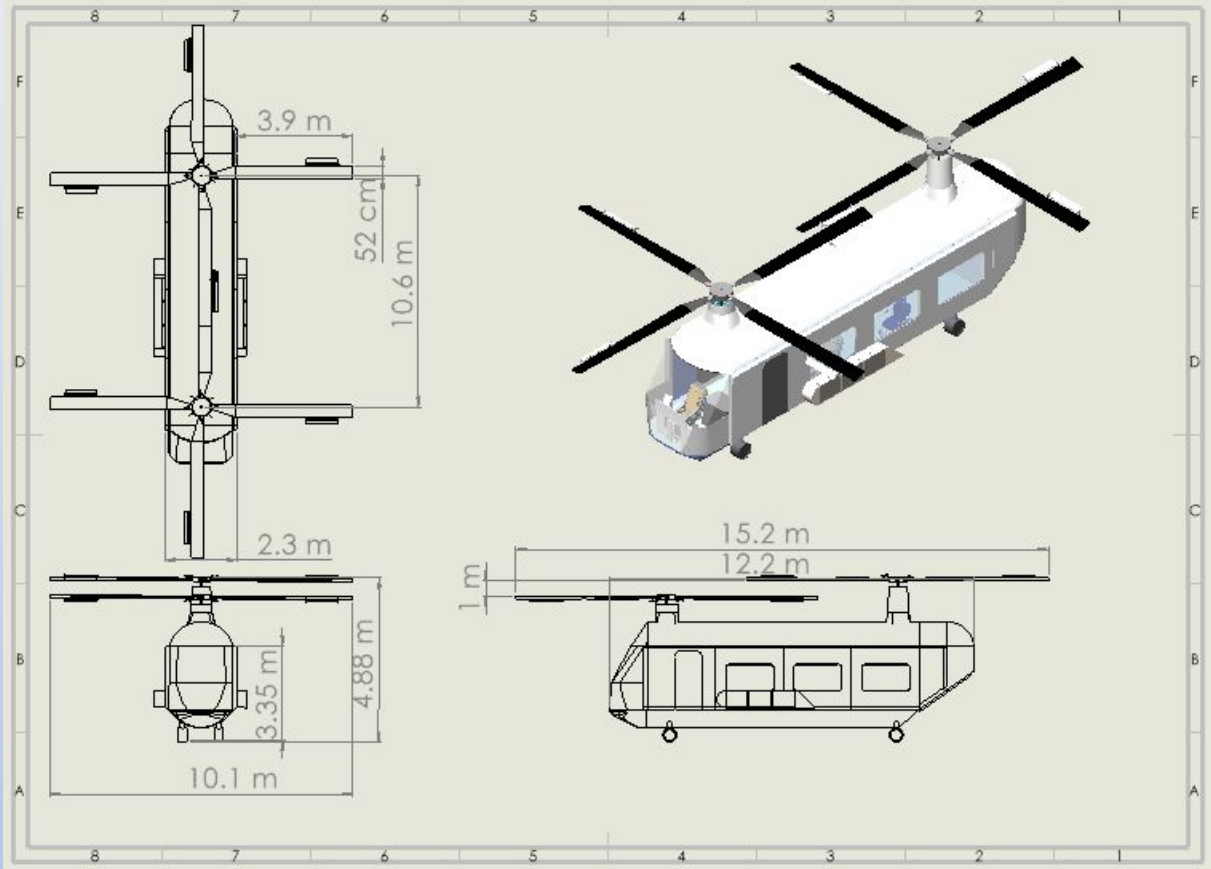

Interior luggage compartments

Designated wheelchair securement locations

Tracks for chair reconfiguration

Mission Profile

Per the RFP, the mission was broken down into the following segments:

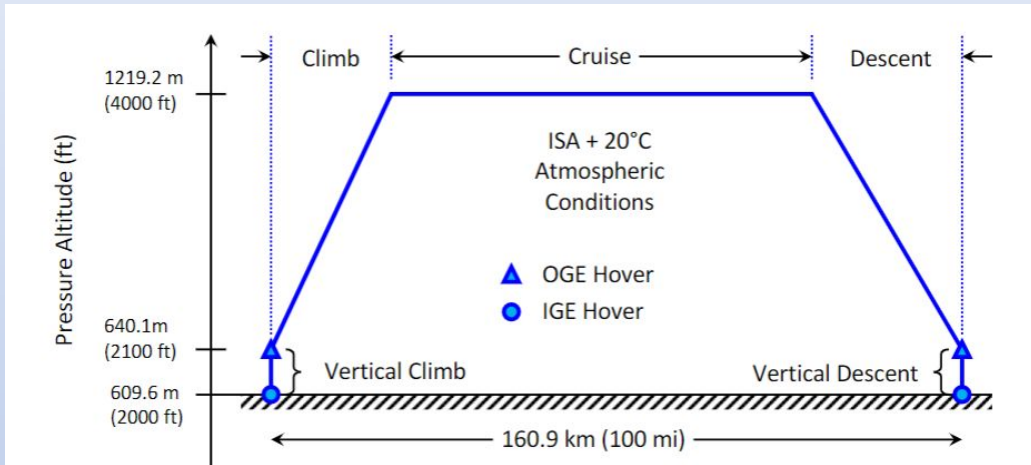

Mission Segment	MG-76 Segment Durations
1) Vertical Takeoff to Hover	5 seconds
2) IGE Hover	10 seconds
3) Axial Climb	38 seconds
4) OGE Hover	10 seconds
5) Forward Climb	1 minute 10 seconds
6) Cruise	53 minutes 20 seconds
7) Forward Descent	1 minute 10 seconds
8) OGE Hover	10 seconds
9) Axial Descent	1 minute
10) IGE Hover	10 seconds
11) Vertical Landing from IGE Hover	5 seconds

Concept of Operations

Facility Requirements:

- Sufficient landing zones for multiple aircraft
- Charging stations at take off and landing sites
- Hangars and maintenance facilities
- Located nearby transportation hubs for passengers to easily move between the air taxi and ground transportation (buses, trains, automobiles)
 - Especially important for passengers with disabilities who may require accommodations only available on public transit

For Physically Disabled Passengers:

1. Ramp will be open for wheelchair/limited mobility access
2. Passengers will board through ramp, ground crew will fix wheelchairs to hardpoints in cabin, place belongings in respective storage bins
3. Crew will deboard and ramp will be raised into closed position

For Able-Bodied Passengers:

1. Passengers will place luggage in sponson storage and board through side doors
2. Passengers place carry-on and personal items in respective storage locations and take their seats
3. Crew will ensure everything is secure before shutting doors



Trade Study/Design Selection

An initial trade study was conducted to determine the MG-76 Catacopter performance, motor characteristics, battery requirements and mission parameters. The ARL Trade Space Visualizer (ATSV) utilizes power equations, energy equations, mission time calculations, and battery sizing calculation. This includes 25 Monte Carlo simulations and then 10,000 iterations run using a minimization goal set on the calculated battery weight throughout the flight. Feasibility constraints were applied which included max C_L in hover, tip mach number in forward flight, and the useful load fraction, μ .

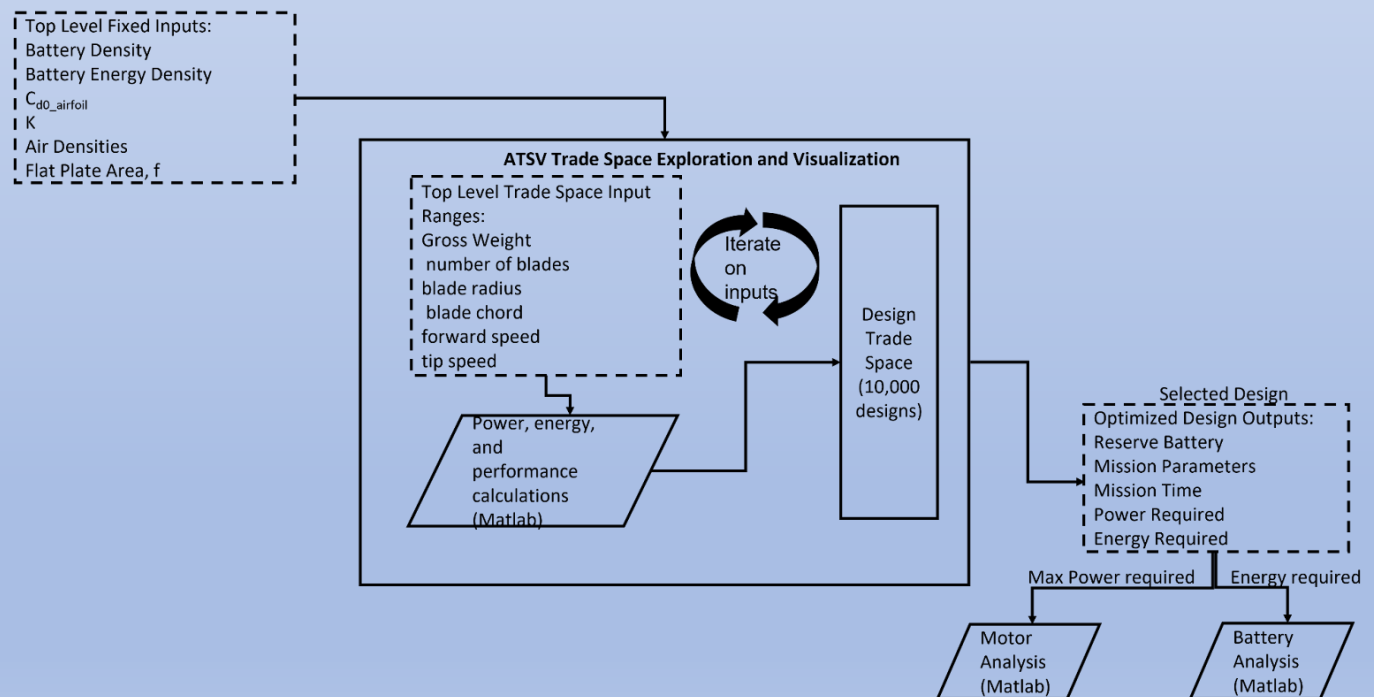



Trade Study Results

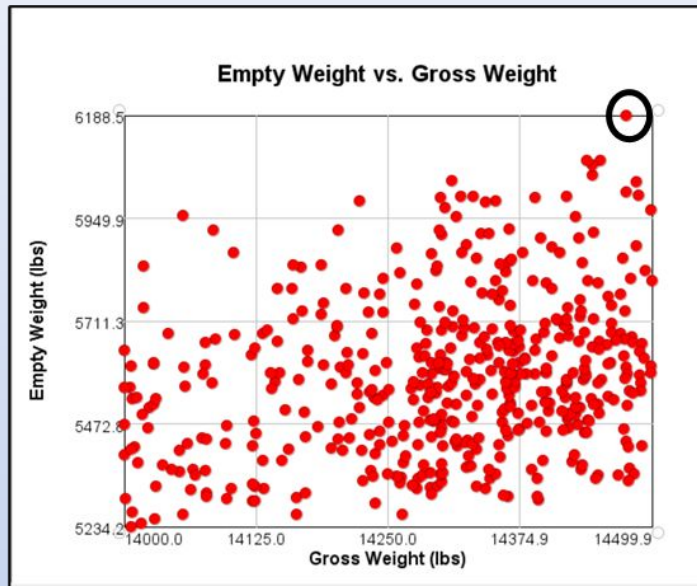
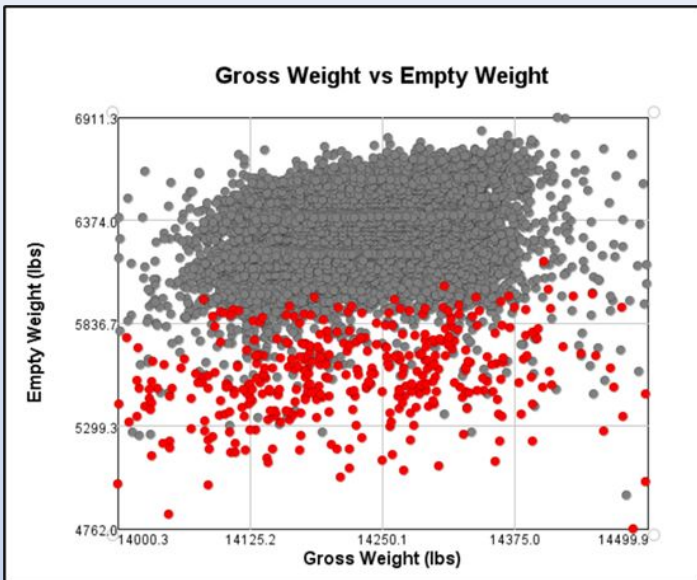

Feasible solutions are shown in red, with each point on the graph representing a single, unique point in the tradespace. Infeasible points were removed from the graph to increase readability which can be seen on the right. Based upon feasible solutions, a gross weight and empty weight were selected for further calculations.

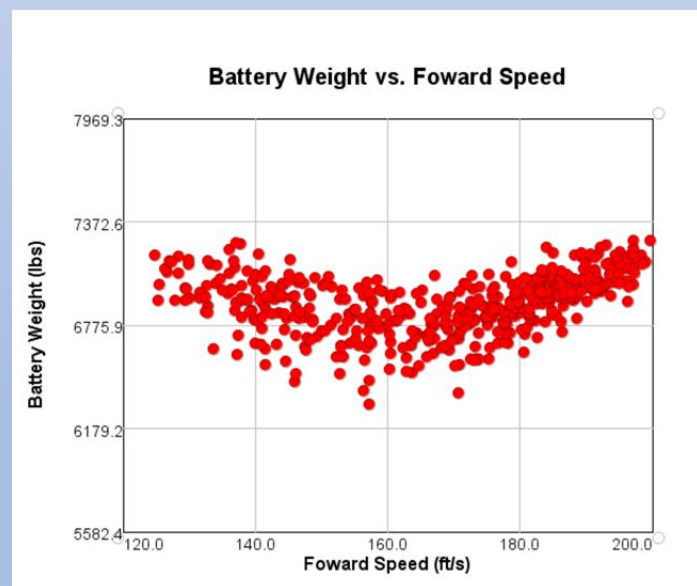

From the trade study simulation, it can be concluded that as the tip speed decreases, the battery weight decreases as well. This causes an increase of coefficient of lift in hover which is shown by the color gradient scale. It was determined that the tip speed can be decreased from the maximum stated in the RFP while also having sufficient stall margin.



Vehicle Performance

The team performed an initial calculation of the flat plate area, taking into consideration the fuselage, sponsons, pylons, and landing gear. It was determined that the equivalent flat plate area was 36.78 ft². Verification of the flat plate area was conducted through a comparison of different operational helicopters and their flat plate area. The table below shows the MG-76 equivalent flat plate area and published values for commercial helicopters of similar size/shape. Based upon the results of the comparison, it was verified that the flat plate area of the MG-76 Catacopter was feasible.

Helicopter	Flat Plate Area (f)
MG-76 Catacopter	36.78 ft ² (3.42 m ²)
CH-47 (RAF HC Mk2)	50 ft ² (4.65 m ²)
UH-60	35.14 ft ² (3.26 m ²)
S-58	37 ft ² (3.44 m ²)
EH-101 (Civilian)	32 ft ² (2.97 m ²)
SA 321	41 ft ² (3.81m ²)

An analysis of the tradespace as completed for the design cruise speed of the vehicle. With the rotor dimensions and gross weight of the vehicle fixed, a study was completed to minimize the energy used in flight. There was a minimum in battery weight found at 158 ft/s. This minimum battery weight is then utilized to further calculate the battery volume necessary for the MG-76 Catacopter.



Battery

- Electric car batteries were used as inspiration for weight and volume estimates due their operational use and higher TRL level over batteries used in current aircraft
- Review of electric car batteries indicated that the Chevy Bolt possessed the highest density and lowest packing volume.
 - The team determined this was representative of a future, idealized 400 W-hr/kg battery technology

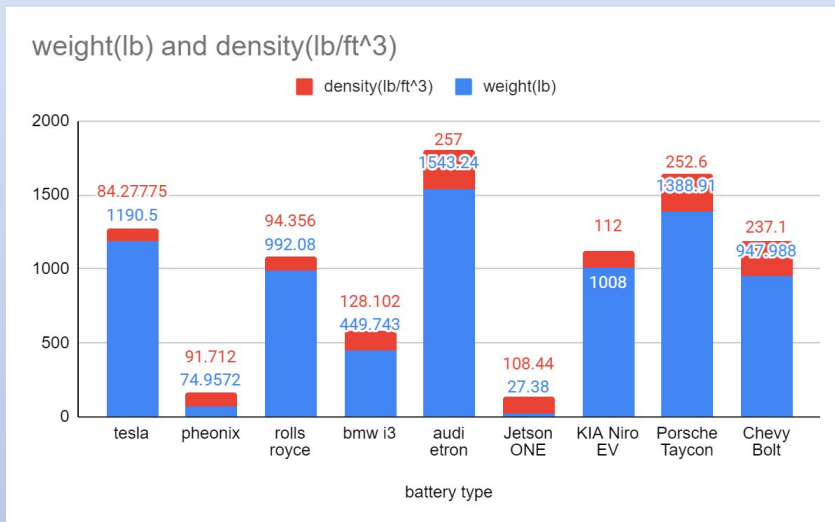

- Includes 20 minutes of continuous reserve power in case of failure
- Battery located below cabin floor
- Utilizes firewall of 14 gauge titanium around battery
 - Each cell group wrapped in aluminum foil and glass cloth as an additional safety feature

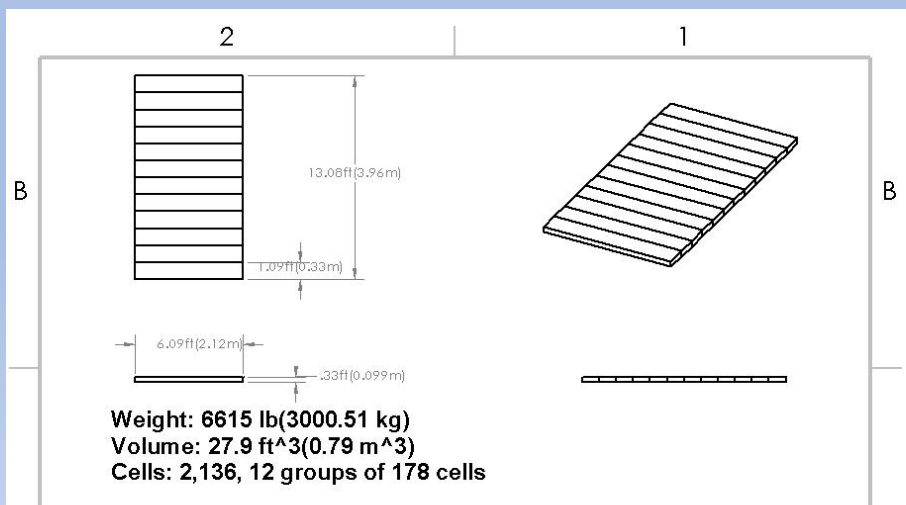



Motors and Speed Controllers

The MG-76 Catacopter is capable of continued safe flight following any single failure of the electrical power distribution system (motor, motor controller, etc.). The team performed a trade study on nine number of motors and selected six EMRAX 348 for MG-76 Catacopter's propulsion system. The motor specification are given in the table below:

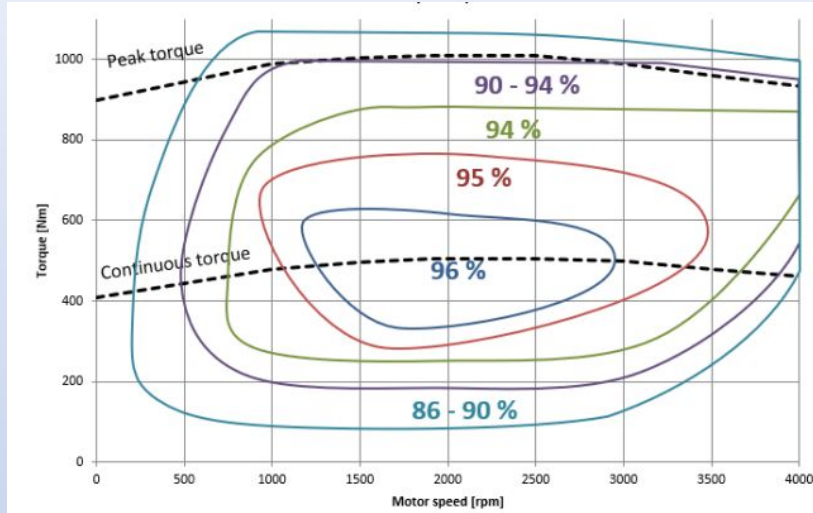

Peak Power	380 kW (509.6 Hp)	Total Peak Power	2280 kW (3057 Hp)
Continuous Power	210 kW (281.6 Hp)	Total Continuous Power	1260 kW (1689.7 Hp)
Peak Torque	1000 Nm (737.6 lbf ft)	Mass	41.5 kg (91.5 lbs)
Continuous Torque	500 Nm (368.8 lbf ft)	Diameter	348 mm (13.7 in)
Efficiency	92-98%	Axial Length	107 mm (4.2 in)

Each motor requires an electric speed controller ESC to regulate the output of the electric motors. The DTI HV-500 was selected for the MG-76 because of its low weight and volume.



ESC Specifications

Maximum Operating Voltage	800 V
Maximum Electric RPM	100,000
Mass	7.2 kg
Dimension	112x 213x 420 mm (4.4x 8.4x 16.5 in)



Synchronizing Drive System / Gearbox

The MG-76 Catacopter will include a gearbox to reduce the motor input speed to the speed required by the rotor and serve as a central location for the input of each three-motor set. The MG-76 will have a drive shaft to synchronize the two rotors, a requirement due to the tandem configuration.

- The first stage has a reduction ratio of 3:1
- The second stage is where the synchronizing driveshaft is connected to each rotor
- The driveshaft is hollow to reduce weight and be made of TI-64
- The third stage is a planetary gear stage with a reduction ratio of 2.33

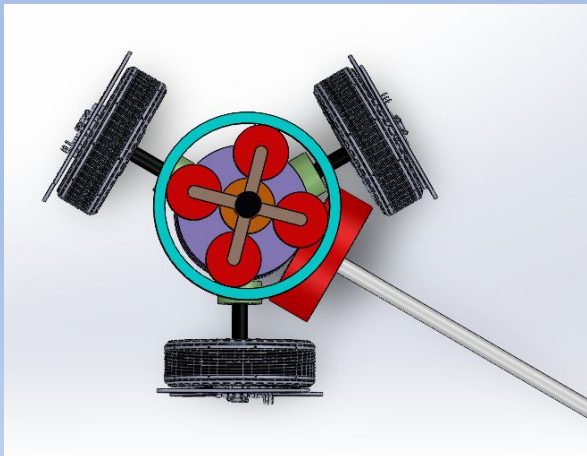
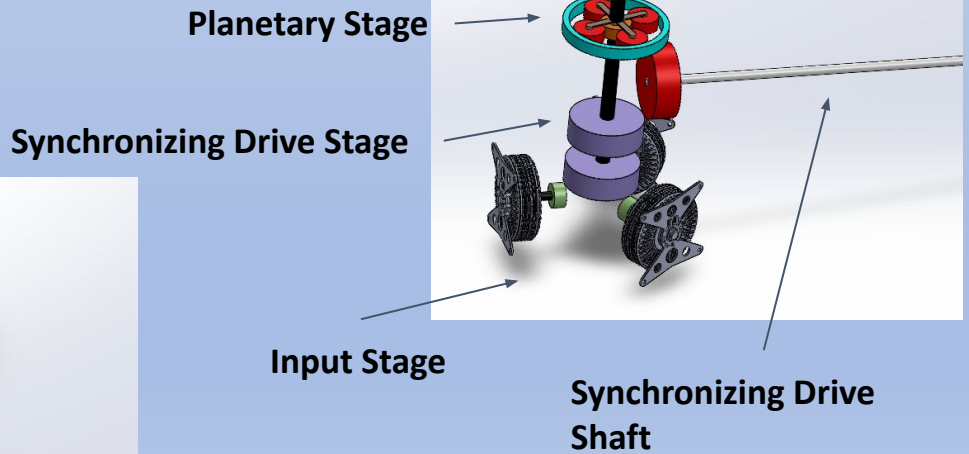
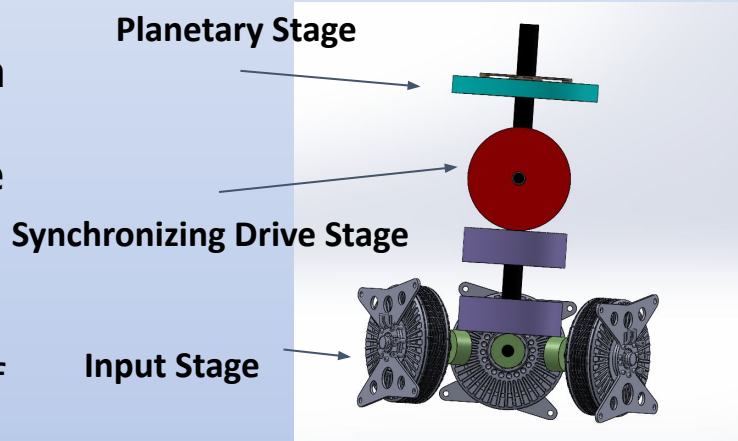

Trim Analysis/Airfoil Selection

Therefore, a MATLAB simulation of the longitudinal aerodynamic forces and moments for a given flight configuration was developed. This simulation was used to determine how the rotors could be optimized for the mission profile.

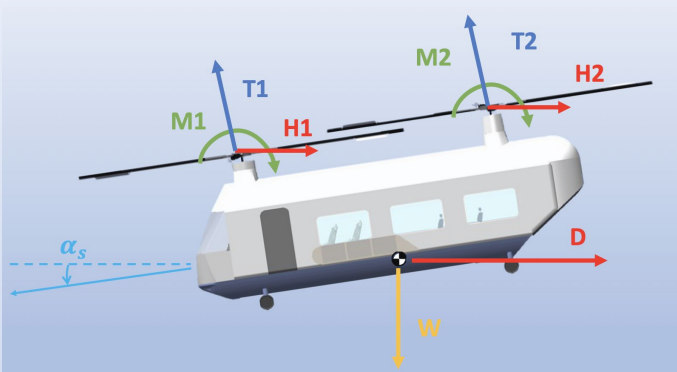

A hinge offset of 10% was used to reduce shaft angle to less than 4 degrees in cruise. This also minimized the blade flapping, decreased vibrational frequency and interior noise.

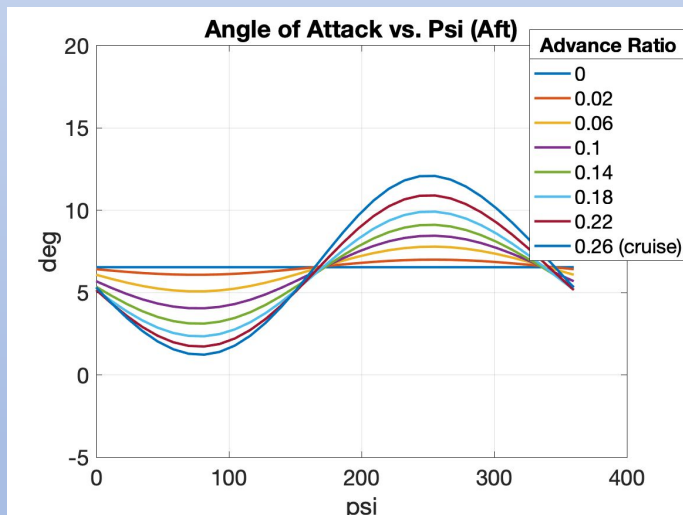
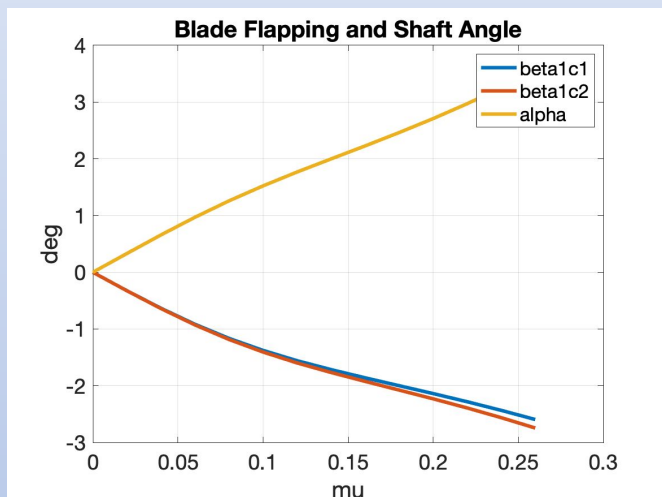

Angle of attack as a function of azimuth angle at the 75% radial position on the blade was calculated based on trimmed orientation of the aircraft. Using the simulation model as guidance the Sikorsky SC101R28 airfoil was selected based upon results from the simulations

Sikorsky SC101R28 Airfoil Shape

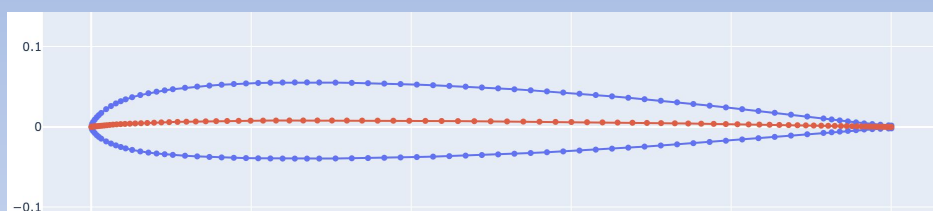

Structure

Sponsons Support - Utilizes carbon fiber graphite composite, used to support checked luggage, attaches to internal frame through bracket connection points

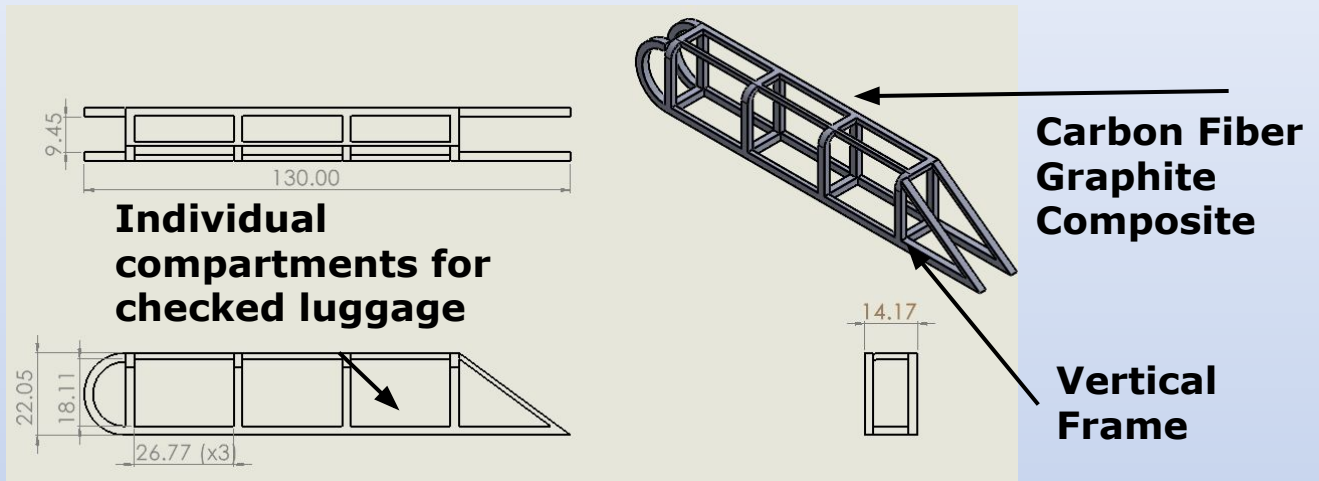

Motor Support - Utilizes Aerospace grade Aluminum 6061 T6 to withstand the torques applied by the motors, located in the pylons of the MG-76 Catacopter

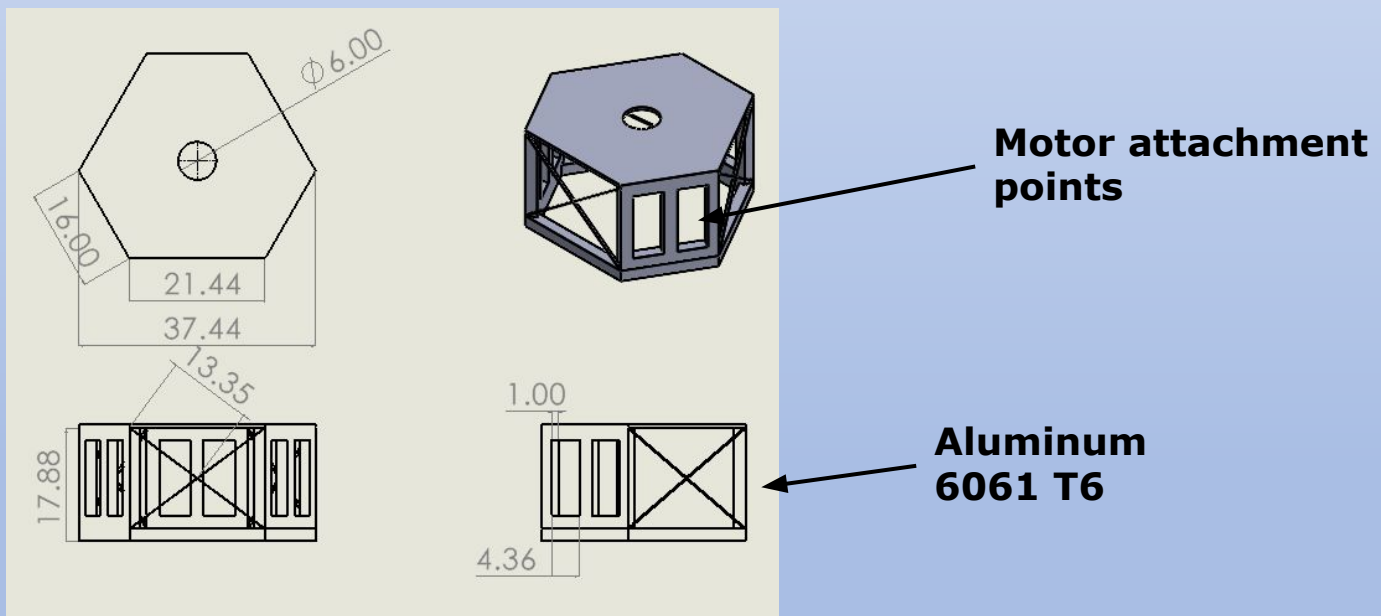

Battery Support (Not Shown) - Utilizes carbon fiber graphite composite placed below the floor of cabin. Includes latches to ensure batteries are secured during flight.

Internal Frame (Not Shown) - Utilizes carbon fiber graphite composite for horizontal stiffeners and vertical frames. Internal frame created with I beams.

Storage Compartments

Checked Luggage Storage

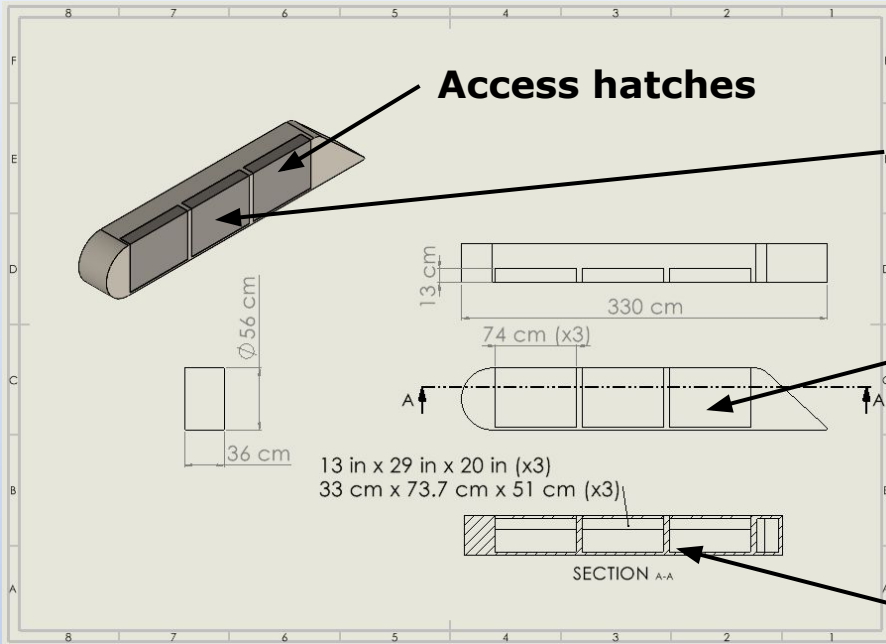

Carbon fiber graphite composite skin

Carry three checked luggage

Dividers between luggage as safety feature (ABS plastic)

Carry-on Luggage Storage

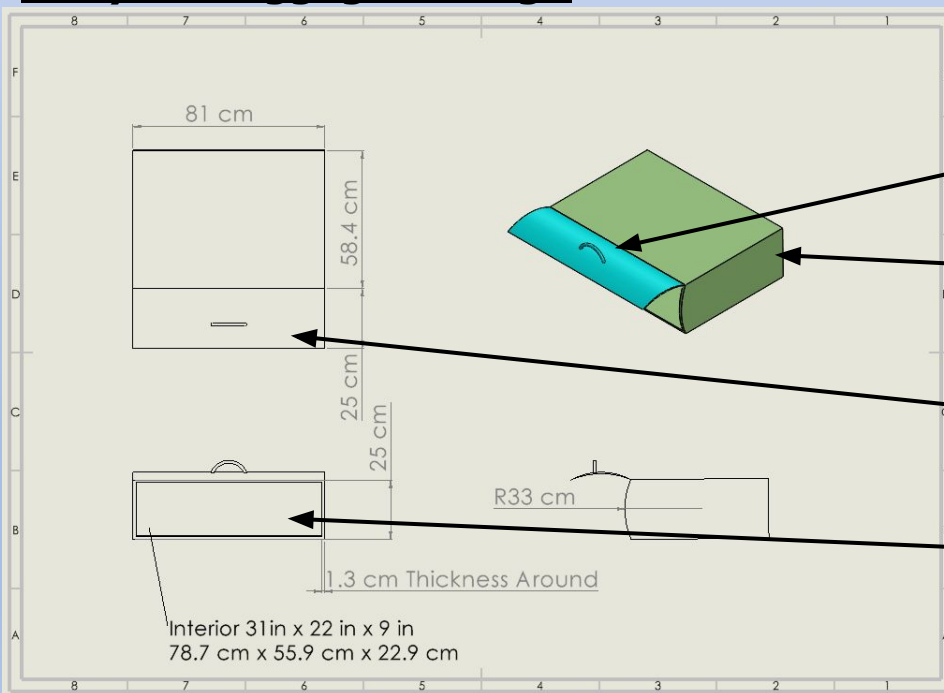

Accessible handles

ABS plastic

Dividers between luggage as safety feature



Carry two carry on items per container

Personal Item Storage (Not Shown)- Container designed to hold personal items and medical equipment. Velcro-latched lids as a safety feature, container made out of plastic and fabric.

Weights and CG

Component	Weight (kg/lbs)
Main rotor blades	82/180
Main rotor hub & hinge	30/67
Landing Gear	56/124
Engine Installation	35/76
Drive System	133/293
Cockpit Controls	14/31
Electronics	10/23
Instruments	38/84
Avionics	68/150
Furnishings and Equipment	141/312
Powerplant	49/109
Battery	3001/6615
Body	1285/2832
Luggage	188/415
People	454/1000
Weight Reserve (10% of Empty Weight)	559/1232

Total	Weight
Operating Empty Weight	6147 kgs (13551 lbs)
Operating Gross Weight	6789 kgs (14967 lbs)

CG Location (Distance from Nose)		
Average	Maximum Forward	Maximum Aft
7.41m (24.31ft)	7.05m (23.12ft)	7.68m (25.20ft)
		

Longitudinal CG flexibility allows for increased aircraft stability and versatility with passenger seating.

Center of Gravity of MG-76 Catacopter

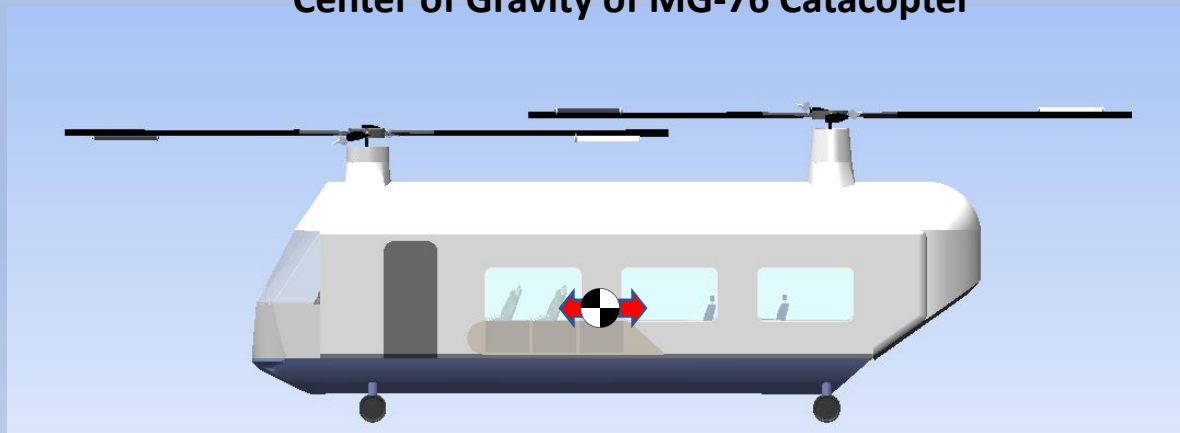



Single Pilot Cockpit Layout

3D Model of Cockpit

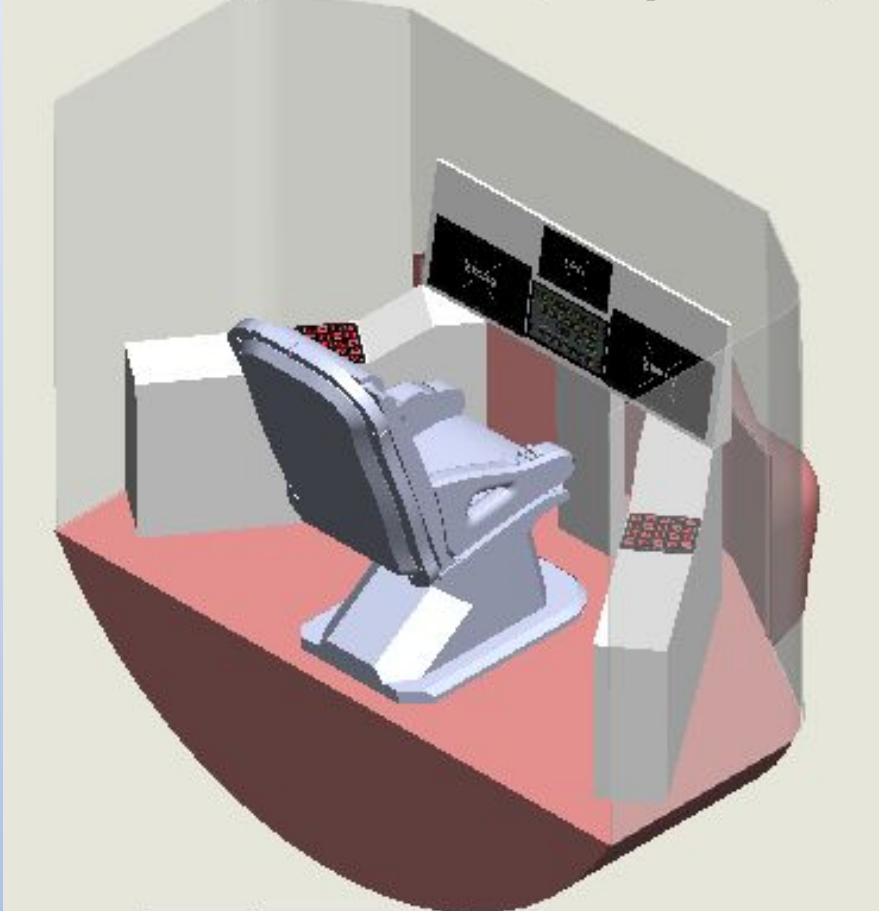

Advance Flight Display



Corporations, Universal Avionics Systems. "Universal Avionics Systems Corporation: EFI-890H: Advanced Flight Display." Universal Avionics Systems Corporation | EFI-890H | Advanced Flight Display, <https://uas.com/home/shop/avionics/efi-890h>.

Cyclic Stick



"Bell 525 Collective Grip." Essex Industries, 24 Nov. 2021, <https://essexindustries.com/products/bell-525-collective-grip/>.

With a centrally located chair and collective and cyclic sticks attached to the arm rests, the cockpit prioritizes ease of use. On the dashboard are three large, configurable displays, as well as a permanent artificial horizon. On either side of the pilot are angled panels with communications and system status screens. Chin windows are also located at the pilot's feet around the yaw control pedals to increase downward visibility on landing and takeoff.



Emphasis on Disability

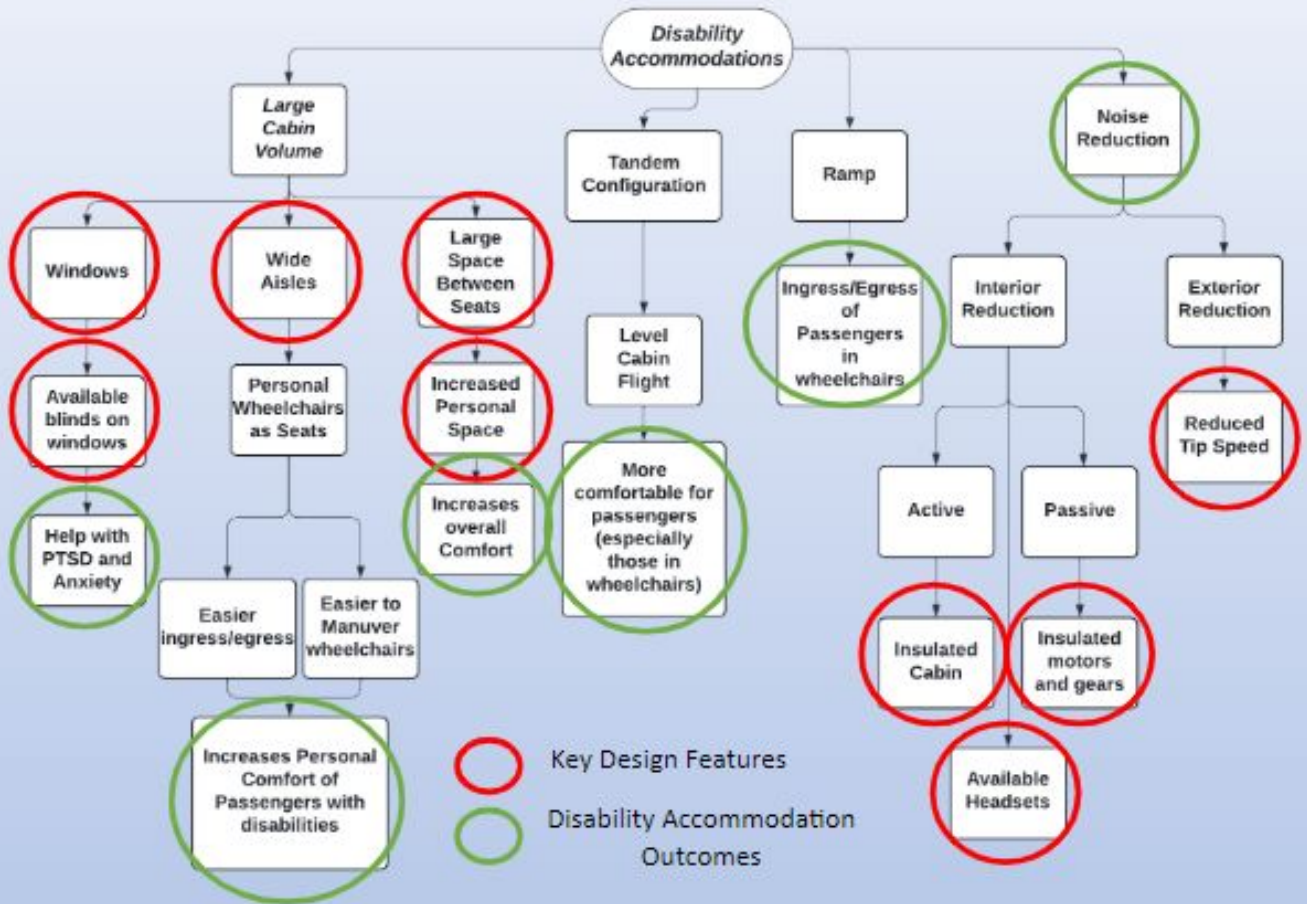

Usable Cabin Volume Comparison

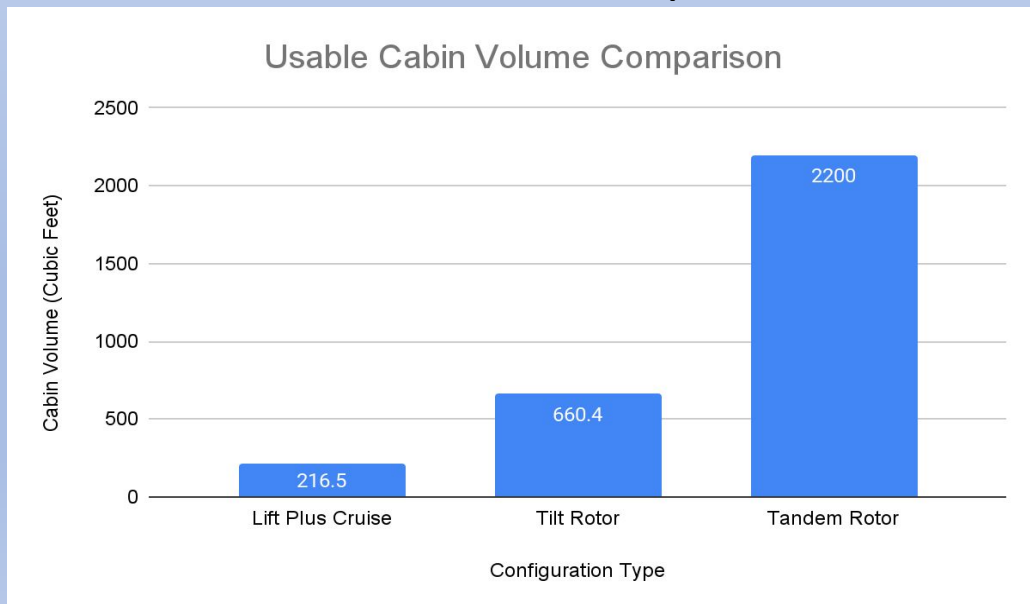

The large cabin volume of the MG-76 Catcopter configuration allows for the most disability accommodations when compared to the other configurations.



Summary

The MG-76 Catacopter air taxi optimizes cabin volume and mission efficiency, providing a comfortable, safe, and reliable transport for all passengers. The interior cabin of the Catacopter is designed to give passengers the most secure and safe flight possible, no matter their situation.

