

DEMIRKANAT HELICOPTER TEAM

istikbal göklerde dir...





CONFIGURATION SELECTION

	Parameters						
Design	Structural Integrity	Energy Consumption	Motor Location Noise and Inspection	Ride Quality	Ease of Board and Egress	Complexity	Final Score
	15	20	20	10	20	15	
Single Main Rotor	3	5	3	1	1	4	295
Quadcopter	3	4	2	4	3	3	310
Hexacopter	2	3	1	3	3	1	215

- Easily accessible entrance and exit for wheelchair passengers
- Large windows for claustrophobia
- Efficient aerodynamic design



REQUIRED PERFORMANCE RATINGS



- Performance calculations were made to calculate the thrust, torque and power requirements required for each design configuration and to select the controller accordingly.

Configuration	Thrust(kg)	Power (kW)	Torque (Nm)	Motor Model
4 Rotor (5000 ft)	2203	400.7	398.2	Yasa 750R
4 Rotor (Failure Mode IGE)	2190	398.5	376.6	
6 Rotor (5000ft)	2450	541.4	288.1	MGM Compro REB90
6 Rotor (Failure Mode IGE)	2510	554.6	297.2	
Single Main Rotor (5000ft)	2349	413.8	11723	EMRAX 348

Motor Model	MAX RPM	Power (kW)	Torque(Nm)	efficiency (%)	Drive Type	Motor Controller
YASA 750R	up to 3250	70	400	95	Direct	YASA Si400
MGM Compro	up to 4000	60-70	300	-	Direct	MGM Compro
EMRAX 348	up to 4000	210	500	92-98	Geared	EMRAX

WEIGHT BREAKDOWN



- Weight breakdown calculations were made using Prouty equations.
- As a result of the calculations made, the most advantageous in terms of weight is the quadcopter configuration.

Component	4 Rotor (kg)	6 Rotor (kg)	Single Main Rotor (kg)
Main Rotor Blades	99.59	77.87	87.80
Fuselage	80.91	86.33	119.71
Skid	40.00	40.00	40.00
Cockpit Controls	9.60	10.13	8.62
System Control	0.91	0.91	0.91
Furnishing and Equipment	42.87	50.91	29.81
Air Conditioning	16.69	19.05	12.62
Baggage	172.00	172.00	172.00
Passengers	400.00	400.00	400.00
Motors	296	264.00	84
Controllers	33.60	50.40	70.00
Battery	807.00	991.23	851.63
Invertor	60.84	91.26	62.00
Cables	5.10	6.02	12.70
Actuator	8.27	8.27	8.27
Avionics	115.90	115.90	115.90
Hub and Hinge	-	-	44.94
Horizontal Stabilizer	-	-	7.85
Fin	-	-	17.03
Tail Rotor	-	-	7.54
Transmission	-	-	92.23
Total	2190.21	2384.04	2245.58

MISSION PROFILE



- 79 minutes 56 seconds mission completion time
- 1166782 kJ total energy consumption

4 Rotor Configuration				
Altitude(ft)	Section	Power(kW)	time (sec)	Energy(kJ)
2000	IGE Hover	404.4	10	4044
2100	Vertical Climb	454.31	37.5	17036
2100	OGE Hover	430.99	10	4309
4000	Steady Climb	322.89	116	37408
4000	Cruise	243.89	3136.0	764980
2100	Steady Descent	163.84	207	33924
2100	OGE Hover	430.99	10	4309
2000	Vertical Descent	108.13	37.5	4054
2000	IGE Hover	404.4	10	4044
4000	Reserve Energy	243.89	1200	292674
Total			4774 (79.56 min)	1166782

FORWARD FLIGHT SPEED



- Required Power for Forward Flight : 260.2 kW = 448.9 HP
- Forward flight speed is maximum range speed to obtain low energy consumption

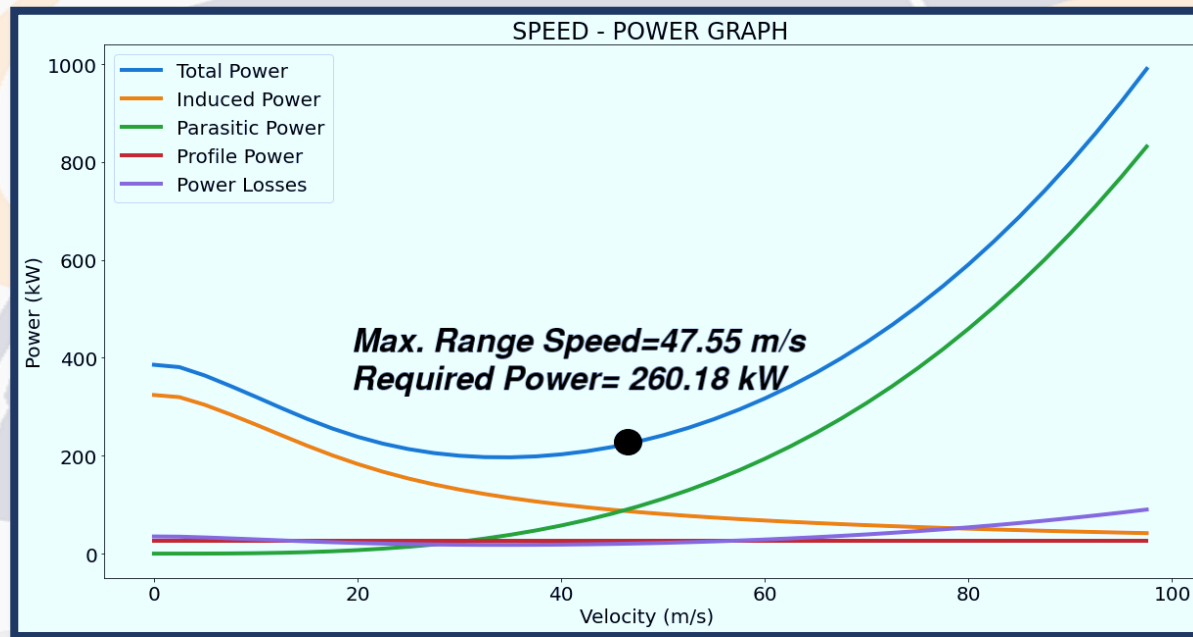

STRUCTURE HIGHLIGHTS



- **Semi-monocoque design**
- **Mighty Bulkhead**
- **Lightness**
- **Torsional Stiffness**
- **Frames at 50 cm intervals**

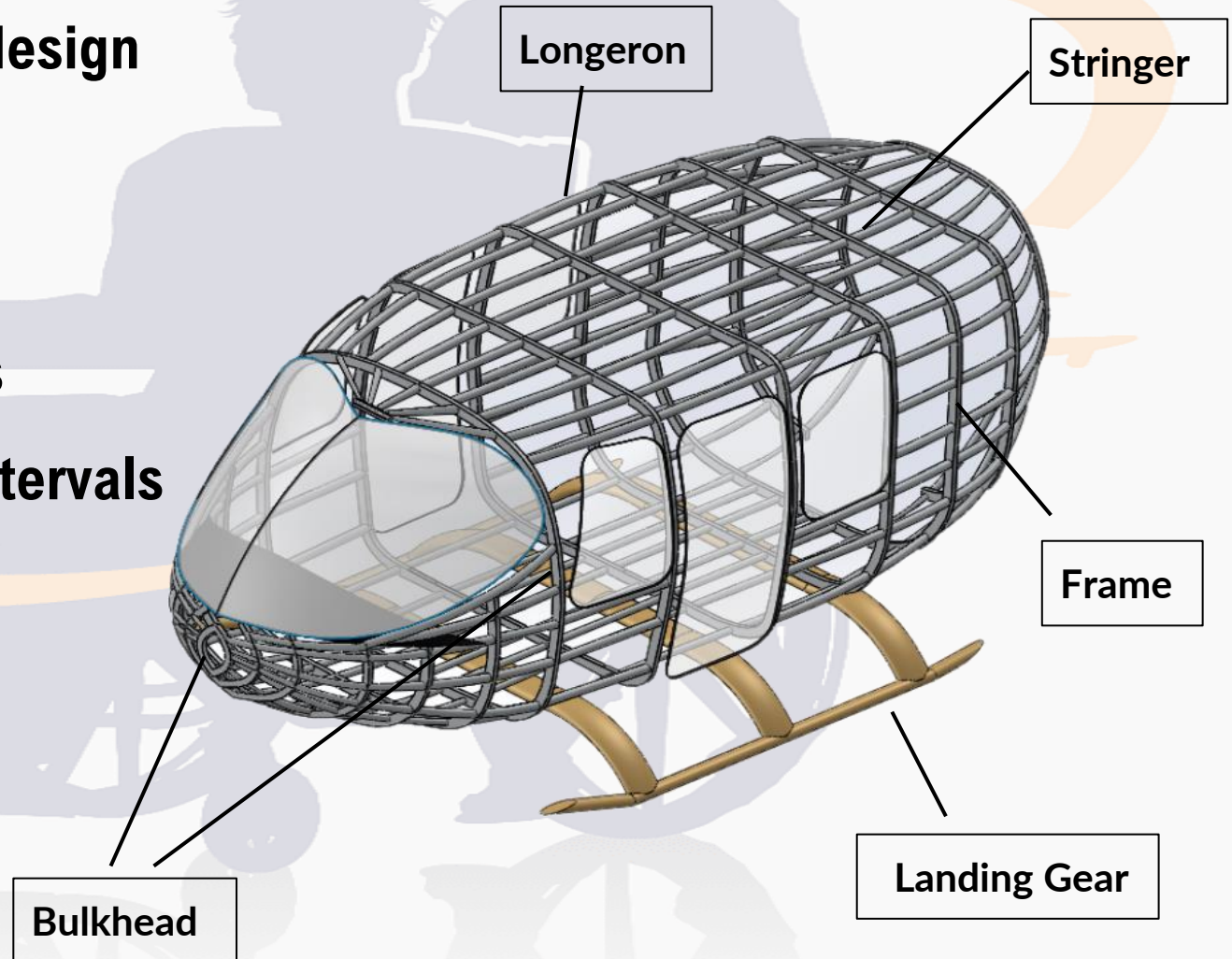

SUB-SYSTEM POSITIONING



No:	Vehicle Sub-systems
1.	Avionics Equipment
2.	Frontal Rotor Systems
3.	Battery
4.	Non-retractable Skid
5.	Baggage Compartment
6.	Pilot and Passenger Entrance Door
7.	Back Rotor Systems
8.	Emergency Exit Door
9.	Cockpit and Passengers Seat

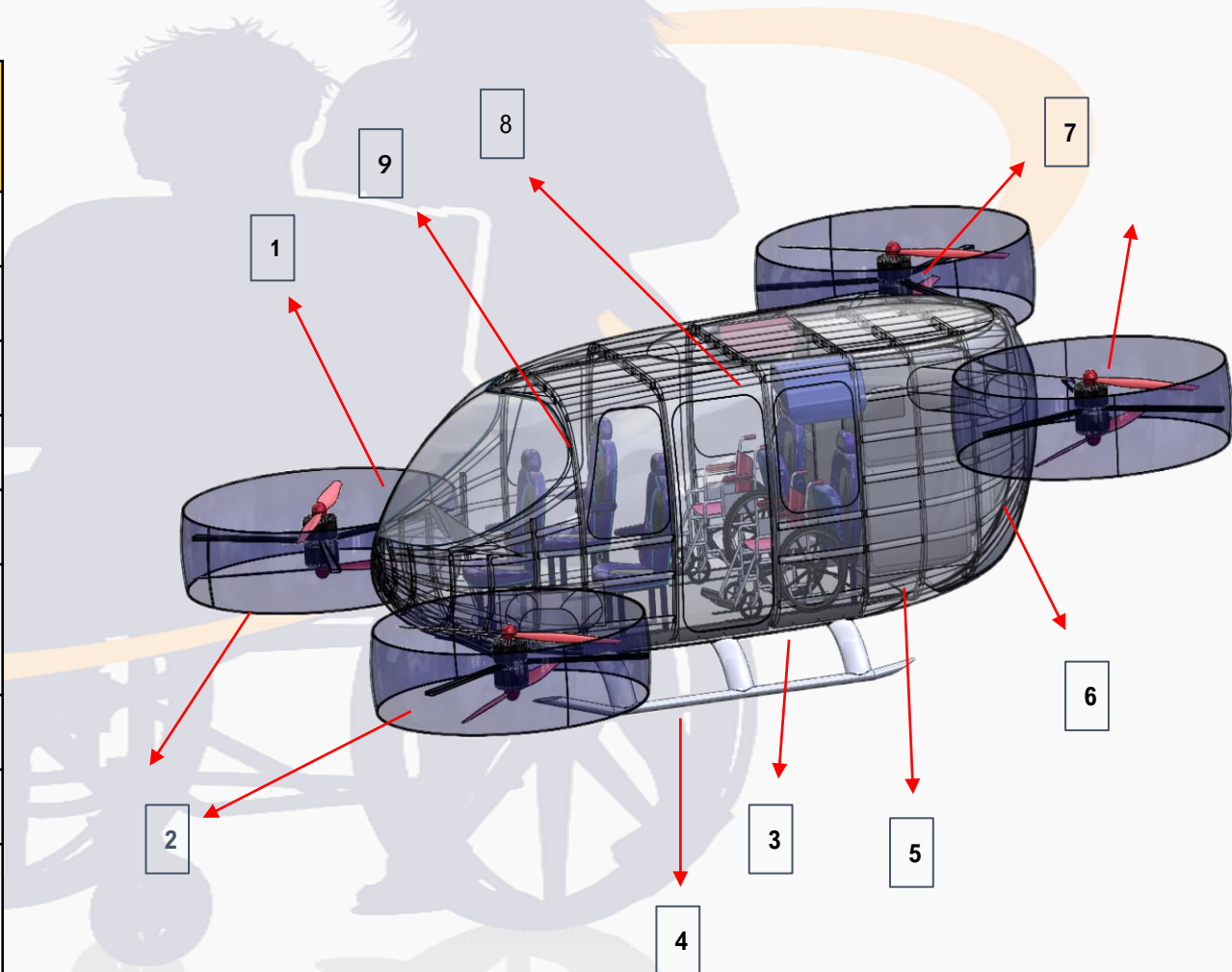

CENTER OF GRAVITY

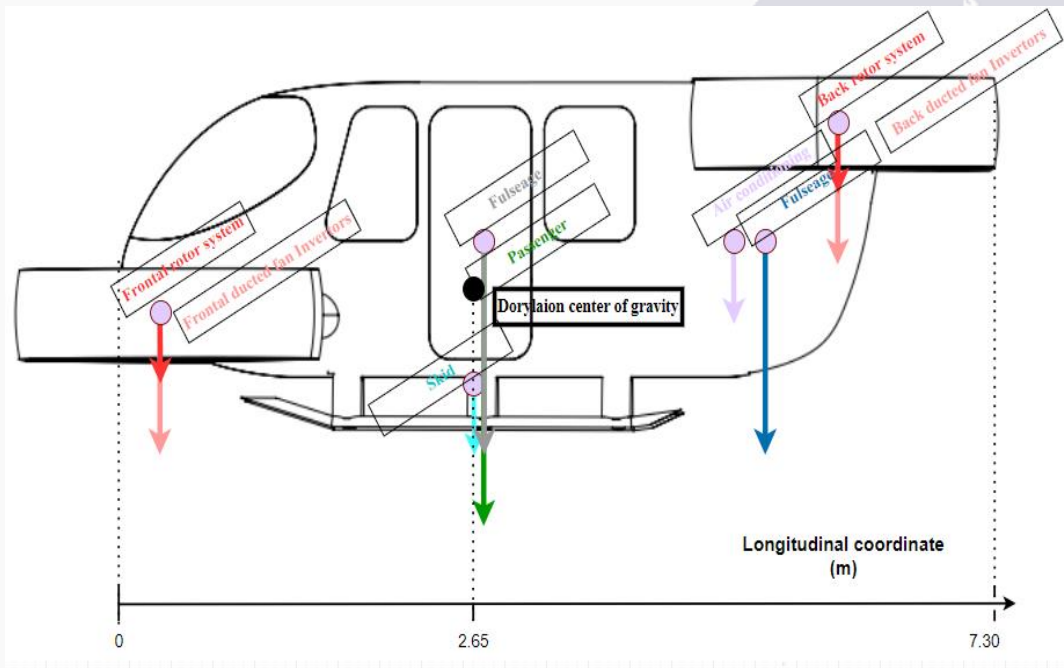

- Center of gravity calculations is measured from the center of the rotor hubs.

- Dorylaion performance was designed in GTOW with 2041.81 kg (4500.15 lb). Components with homogeneous distribution in the vehicle (cabling system etc.) are neglected.

- The Center of gravity is **2.65 m** away from the nose.

INSTRUMENT PANELS AND WINDOWS



DORYLAION'S INSTRUMENT PANELS



- Simplified easy-to-use panel interface as a result of that make flying easier for pilots.
- Flight safety is improved with auxiliary panels used as a backup.

DORYLAION'S WINDOWS

- Reduces infrared radiation
- Approximately 10% reduction in temperature
- Reduces fading of interior fabric and
- weathering of components
- Blocks 99.99% of UV Rays
- Features all the benefits of traditional windows including clarity, durability, ease of removal and replacement

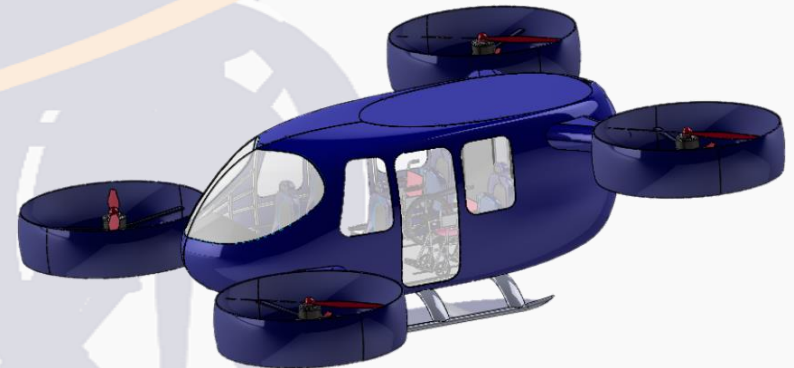

SEATING ARRANGEMENT

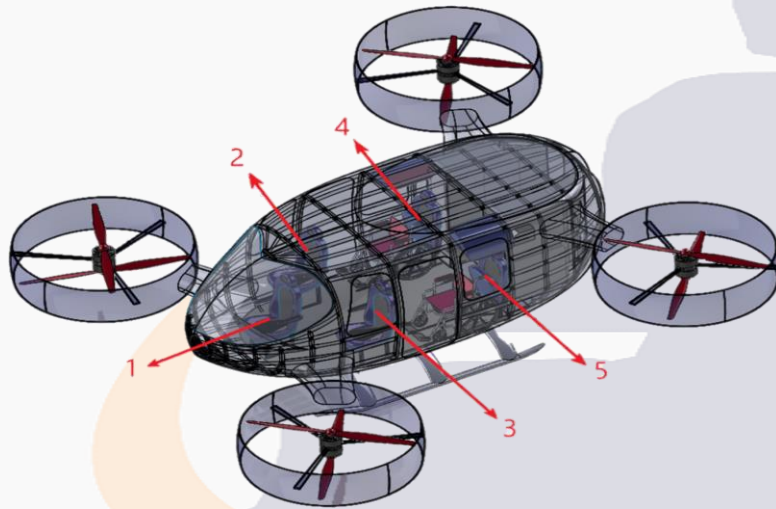

- A seat belt system fixed at 5 points was preferred for the disabled passengers to be fixed during the trip.

- Disabled passengers will travel in seats 4 and 5.
- In this way, they will be closer to the main gate and the emergency exit.
- Entry and exit will become easier for them.

OCCUPANT RESTRAINT SYSTEM

1-Floor attachment

2-Tie-down

3-Wheelchair attachment

4-Occupant belt

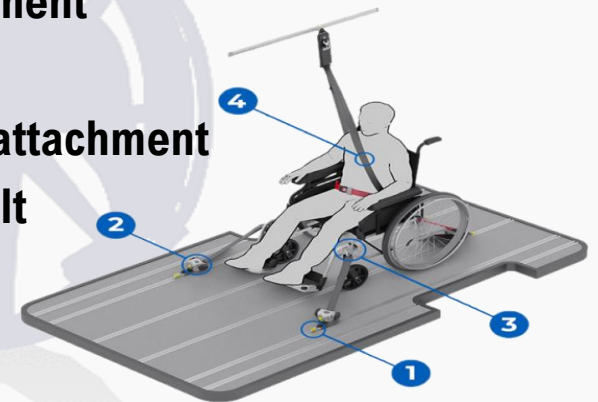

CABIN DESIGN



MAIN DOOR

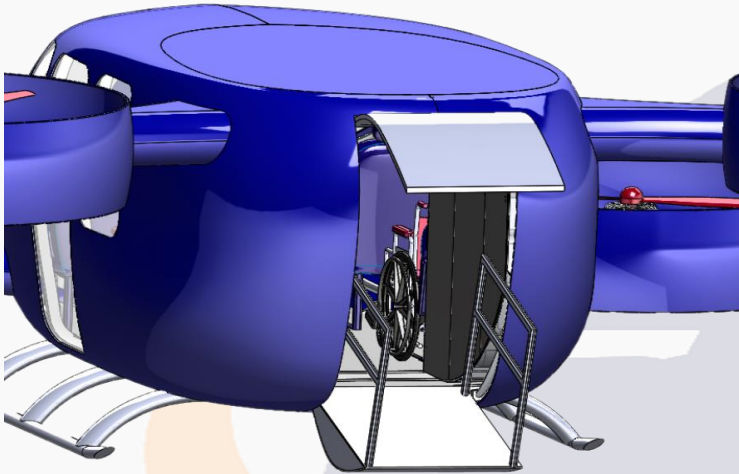

- The main door is located in the rear of the VTOL.
- It turns into a ramp when it is opened to facilitate the boarding and disembarkation of passengers.
- There are also hand grips on the sides.

EMERGENCY EXIT

- Large enough emergency exit doors are installed on both sides of the fuselage.
- It can be opened both from the inside and from the outside.

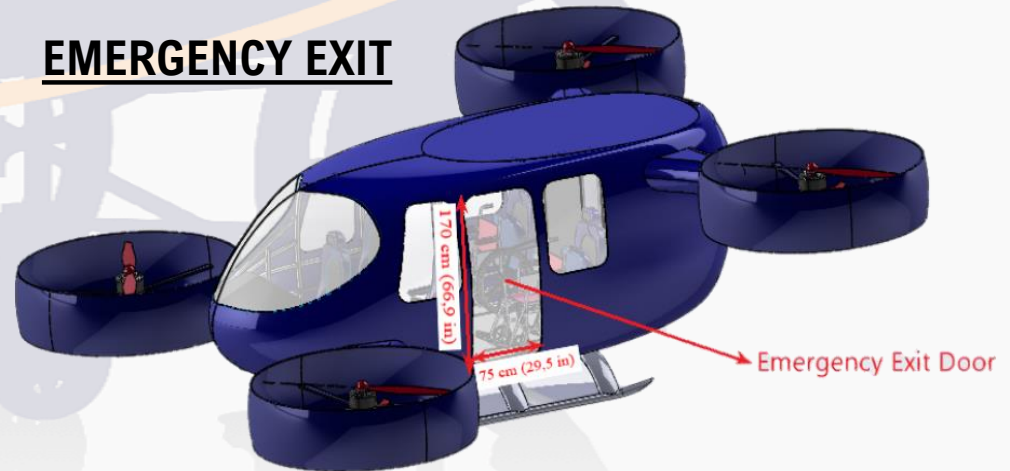

BAGGAGE COMPARTMENT DESIGN

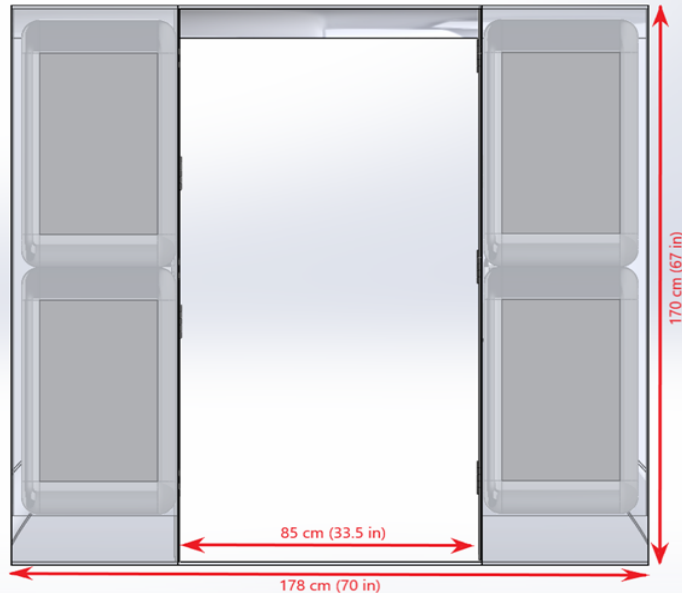

- The baggage load of the passengers was sized using their measurements.
- It is positioned in the rear of our vehicle.

- For the safety of the passengers, the suitcases are secured with safety straps.
- The folding luggage compartment lid was chosen due to the advantage of taking up less space.

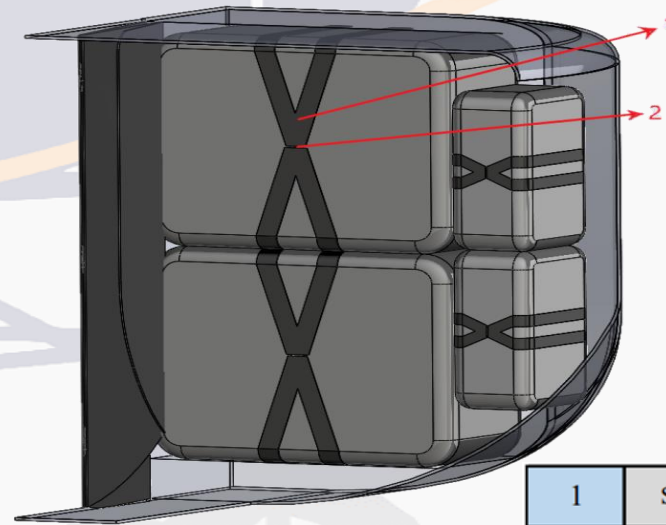

1	Safety Belt
2	Safety Belt Buckle

PROPULSION SYSTEM



MOTOR MODEL: YASA 750R

Peak Torque @ 450 Arms	790 Nm	Continuous Power @ 3000 rpm (40 °C coolant)	Up to 70 kW
Peak Power @ 700 V _{dc}	200 kW	Speed	0 – 3250 rpm
Peak Power @ 400 V _{dc}	100 kW	Peak Efficiency	>95%
Continuous Torque (40 °C coolant)	400 Nm	Mass	37 kg

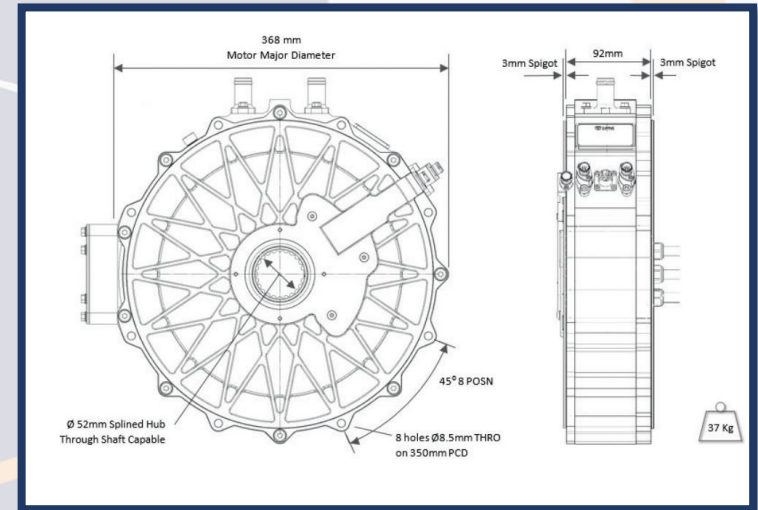

- 8 x 70 kW motors to provide the 400 kW power requirement for hover flight.
- Total installed power: 560 kW
- The ability to meet 398 Nm required torque requirement with a direct drive.
- High efficiency



DESIGN FEATURES



- While performing the performance calculations of the vehicle, optimizations were made with the BEMT method, and the design features were determined.

Design Features	
Rotor Radius	1,6 m
Number of Blades	4
Chord	0.1 m
Number of Rotor	8
Blade Loading	0.13
Twist Ratio	14 deg
Figure of Merit	0,652
Pitch Angle	0,46 deg
Induced Power Factor	1,43

CONTROL SYSTEM

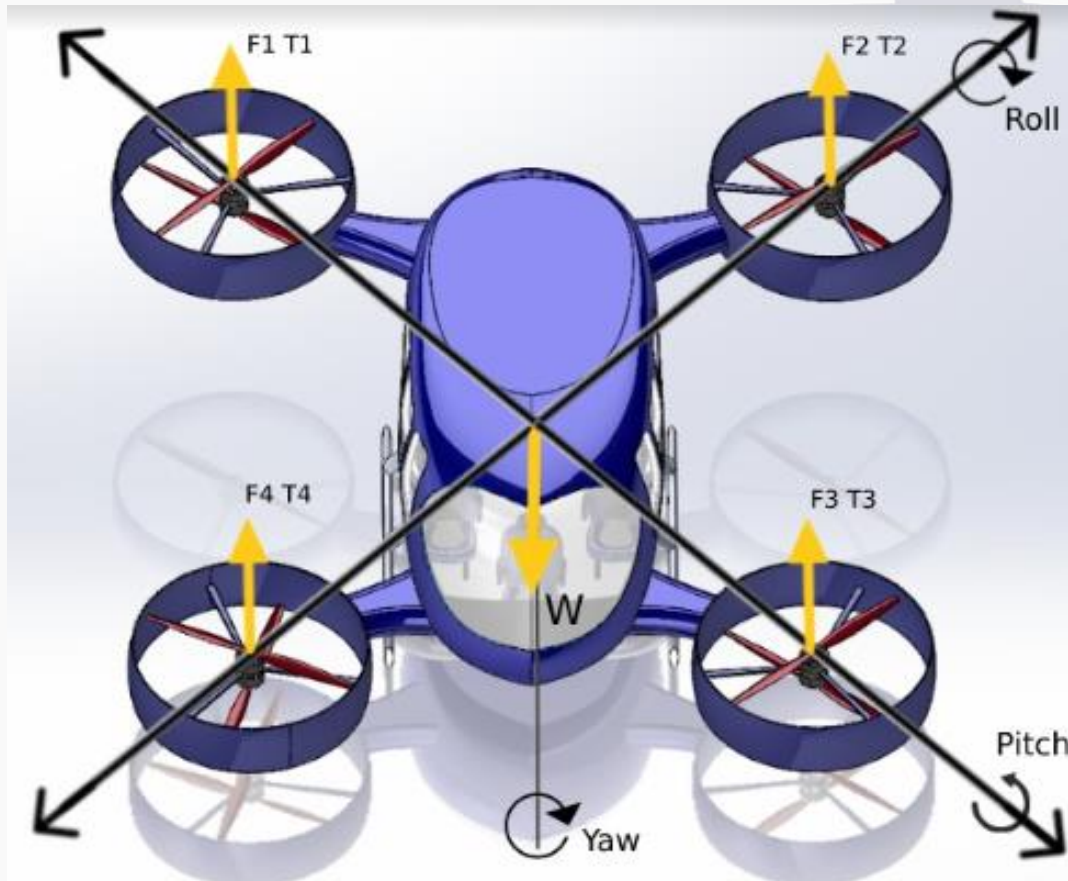

- This image can be called the free body diagram of our electric aircraft. Force and torque are in the same direction and the direction of the weight is opposite to the other two quantities.

CONTROL SYSTEM



- This Simulink image is the control diagram created. The control optimization suite is used to design a controller that meets handling quality standards while lowering actuator effort once a model has been identified.

