

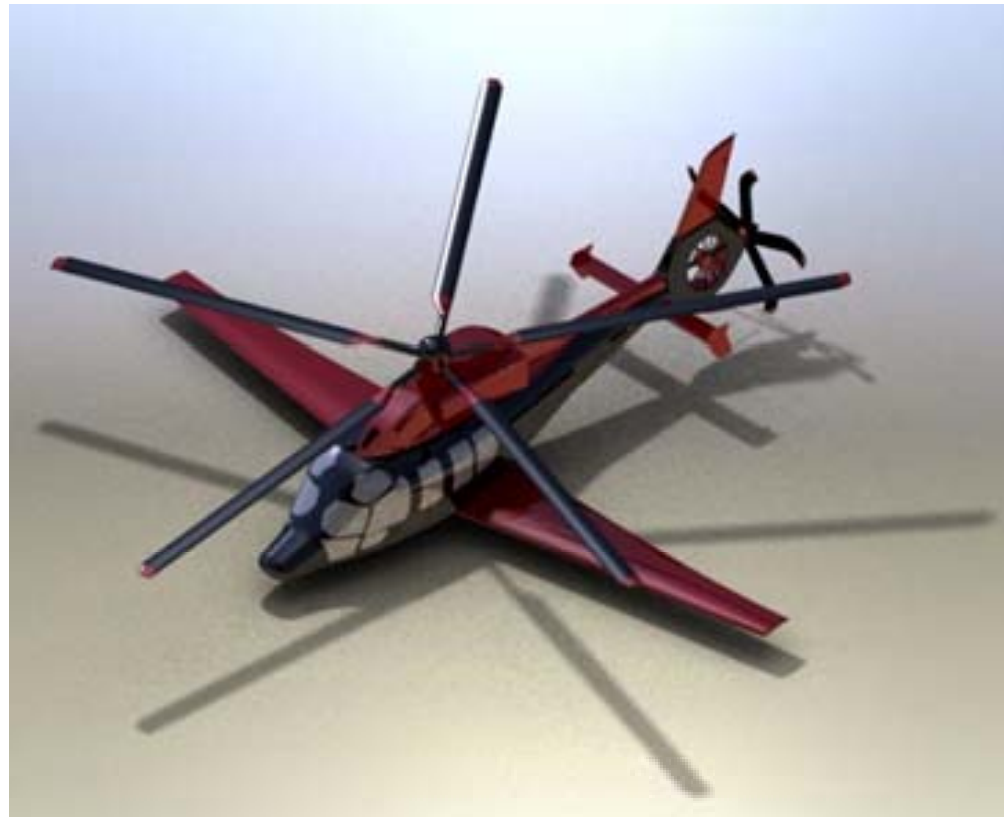

# Penn State Pegasus AHS Design 2009



Elise Baker  
Andrew Brookhart  
Scott Ford  
Michael Jostes  
Ryan Neely  
Peter Romano  
Chris Wilber





---

# Presentation Overview

- Design Selection
- Mission Selection and Overview
- Main Rotor Design
- Rotor Controls
- Transmission and Drivetrain
- Propeller Design
- Drag Buildup
- Weighting and CG location

# Design Selection



Tilting Co-axial Configuration with Jet Propulsion

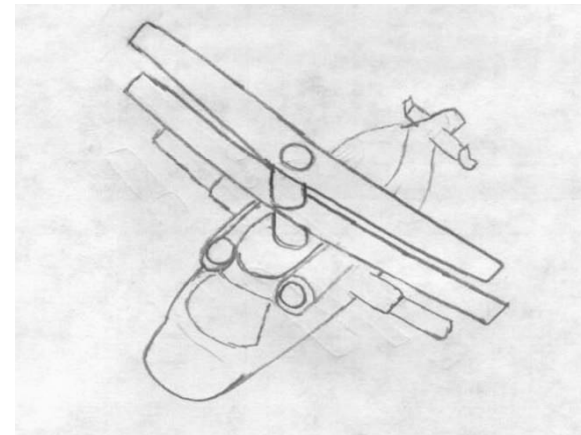

Co-axial Stopped Rotor

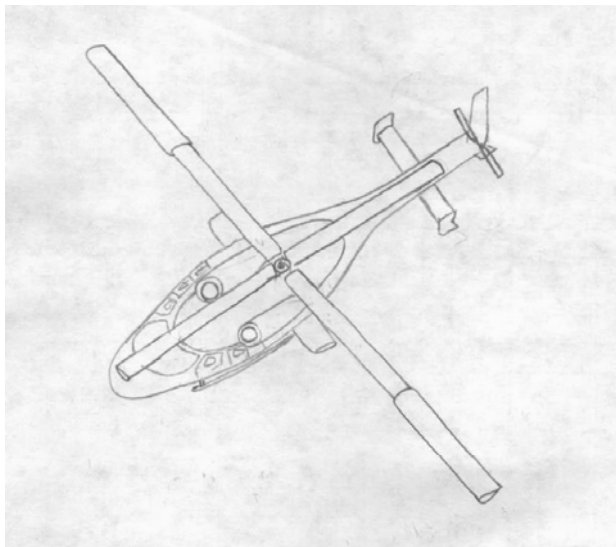

Standard Configuration with Variable Diameter Rotor

The Cheyenne configuration was chosen based on the successes of the design in the past, and the ability of the design's wing to take of lift at cruising speed.

The design, based of an existing EC – 155 airframe, provides unique improvements and new aspect to missions currently performed by this helicopter



# Mission Criteria & Capabilities

Type of Mission	Current Helicopter Commonly Used (US)	Weight class (Kg)	Range Requirements (Km)	Payload Requirements (Kg)	Top Speed Averages (Km/h)
Pegasus	N/A	5000	1300	N/A	554
Military attack	AH-64A Apache	1,000 – 7,000	200 – 700	700-3,000	200-325
Reconnaissance	Bell 407	1,000-3,000	400-700	200-1,000	250-325
Search and Rescue	S-76	4,000-10,000	400-800	1,000-2,500	250-300
Paramilitary	UH-60	1,000-10,000	300-750	1,000-2,500	250-325
Heavy Lift	CH-54A	6,000-25,000	500-2000	3,000-15,000	200-300
Utility Transport	Bell 412	4,000-7,000	500-700	1,000-3,000	225-300
VIP Transport	Mi-17	3,000-15,000	500-700	1,000-5,000	225-300
Police	MD 500	1,000-6,000	200 - 600	200- 4,000	200-300
Medical	S-76	2,000-7,000	400-800	1,000-2,500	250-300
News	EC 120	1,000-3,000	200-400	200-700	200-275



# Mission Summary

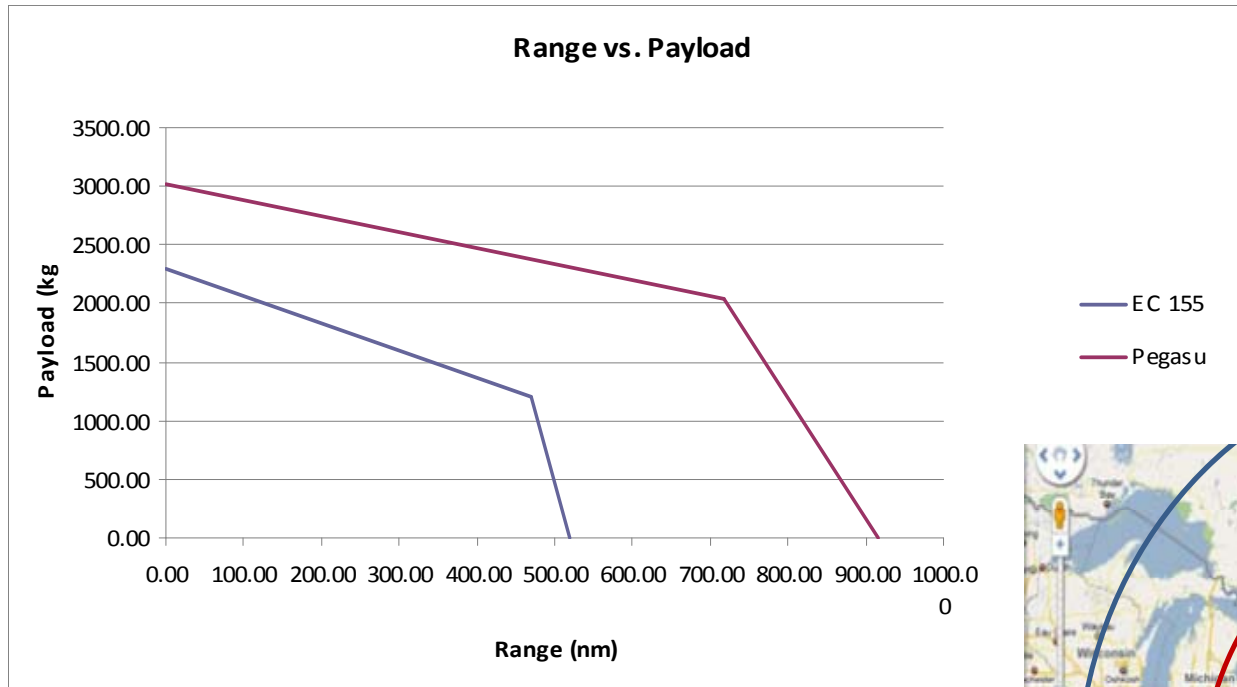

Example Point to Point Mission Centered on New York



## Flight Regime

Maneuver	Time	Fuel Weight (kg)
Takeoff and Hover	10 mins	80
Climb to altitude with Transition	10 mins	120
Cruise (717nm)	3H35min	680
Descent and Transition	10 mins	80
Land and Shutdown	10 mins	80
Reserve 10%		104
<b>Totals:</b>	<b>4H15min</b>	<b>1040</b>



---

# Missions Summary

- The Pegasus has clear advantages in range and speed over the conventional helicopter
- These advantages give the Pegasus the ability to greatly expand its role in current and future missions requiring vertical takeoff and landing combined with high speed flight



---

# Main Rotor Design

- Vehicle must:
  - maintain hover capabilities
  - have good high speed cruise performance
  
- Modifiable Parameters
  - Number of blade, chord, diameter
  - Airfoil Sections
  - Tip Sweep



# Main Rotor Design

Geometry Comparison		
Parameter	EC-155	Pegasus
Number of Blades	5	5
Blade Diameter (m)	12.6	15
Blade Chord (m)	.35	.4
Solidity	.088	.089
MTOW (N)	48040	57826

- Adding tip sweep helps decrease normal velocities at the tip therefore reducing compressibility effects and keeping rotor power minimal, but because the Pegasus uses a slowed rotor to maintain tip velocities, sweep is not required
- Advantages of blade twist
  - Increases Figure of Merit
  - Offloads tips and places lift distribution over the entire blade
- Disadvantages of blade twist
  - Performance losses in forward flight for twist angles above  $-12^\circ$

Airfoil Selection		
Airfoil	Range Used (r/R)	Thickness
Boeing VR-12	0-.4	10.6%
Boeing VR-13	.4-.8	9.6%
Boeing VR-15	.8-1	8%

- Rotor demands:
  - High lift coefficients for inboard sections
  - Thin airfoil for outboard section
  - Avoidance of compressibility effects at the tip
  - Low pitching moments
- Multiple airfoil sections must be used to meet these demands

# Rotor Control – Lift Sharing

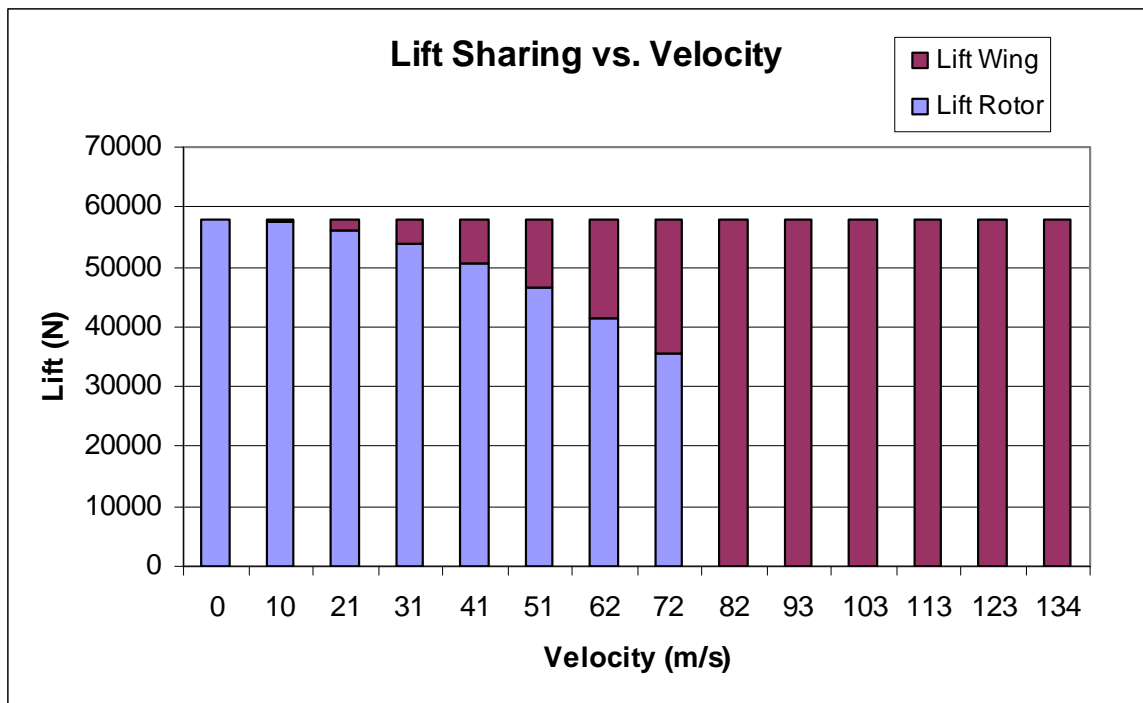

-Wing Loads Slowly

-Rotor Tip Path Plane Level

-Rotor Omega Changes

-Wing Takes over 100% Lift at 80 m/s

-Rotor Slowed, feathered to zero lift



# Rotor Control - Offloading

Induced Power for rotor or wing to carry the same load (lift efficiency)

Does not include retreating blade stall or drag from reverse flow over retreating blade at large incidence angles

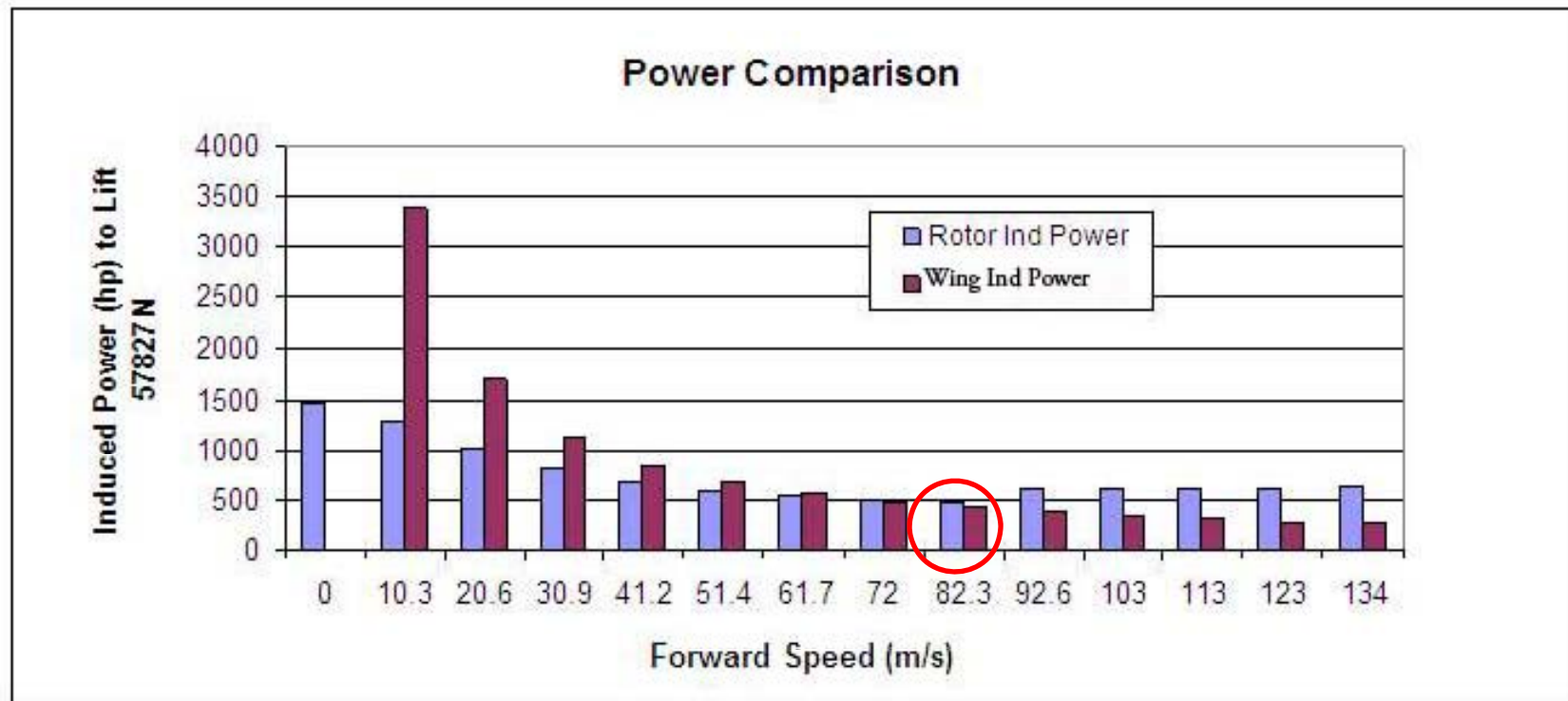

# Rotor Drive System

- Variable Speed Rotor
  - Born out of necessity
  - Forward Flight Parameters
    - Advancing Tip Mach #
    - Retreating Blade Stall
  - Rotor is unloaded at high speeds
  - Drop in rotor speed
    - 343 RPM
    - 171 RPM

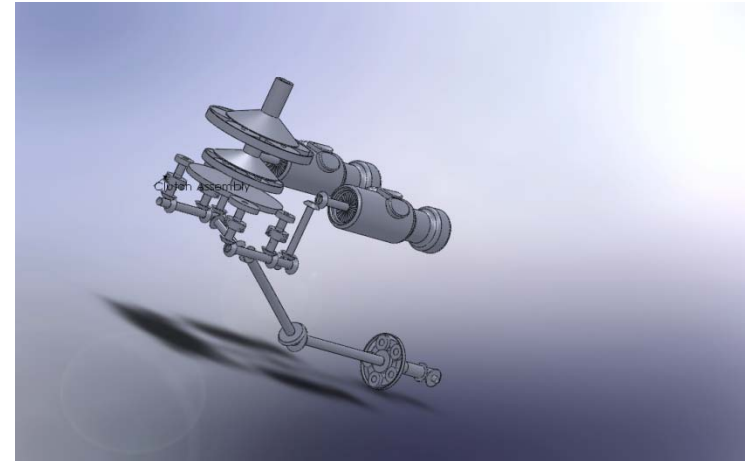

# Rotor Drive System

- Four clutch system
  - 2 high speed gears
  - 2 low speed gears
  - Hover and Cruise
- High Stresses on clutch
- Designed around flight transition point

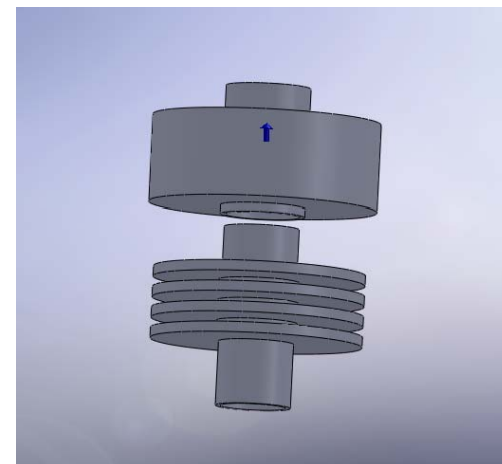
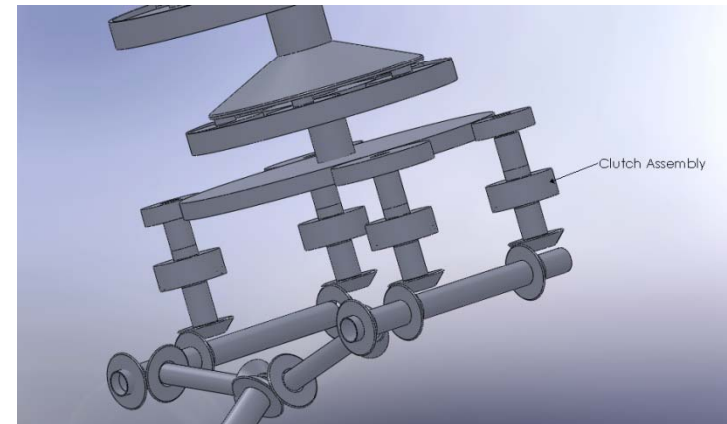



# Propeller Optimization

- Propeller Must:
  - Fit within the current vehicle geometry
  - Produce enough thrust to overcome drag at cruise altitude
- Modifiable Parameters
  - Number of blade, chord, diameter
  - Twist rate
  - Radius
  - Rotational Speed
  - Tip Mach Effects



# Propeller Design

Parameters	
Airfoil	NACA 64 <sub>3</sub> -618
Cruise Efficiency	93%
Cruise Drag Coefficient	.007
Radius (m)	1.5
Spinner Radius (m)	.125
Twist Rate (deg)	-20
Rotational Speed (rad/s)	150
Root Chord (m)	.3
Tip Chord (m)	.3

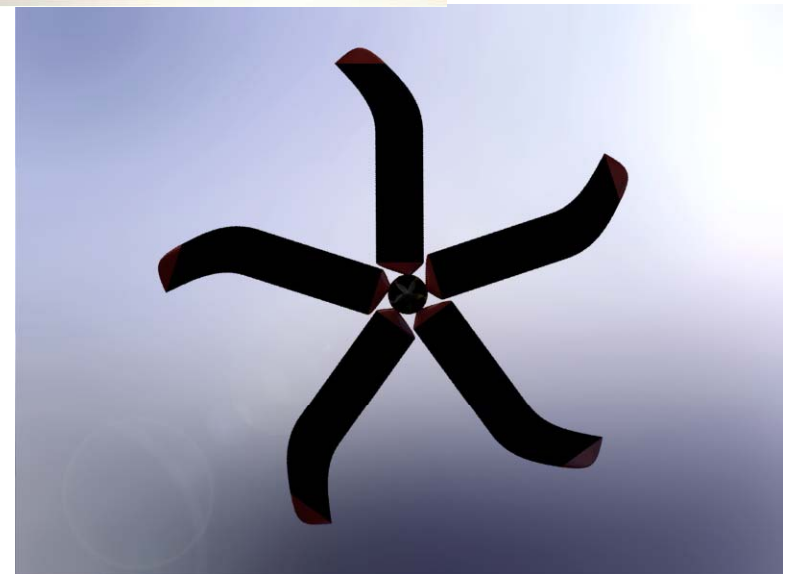



# Drag Buildup

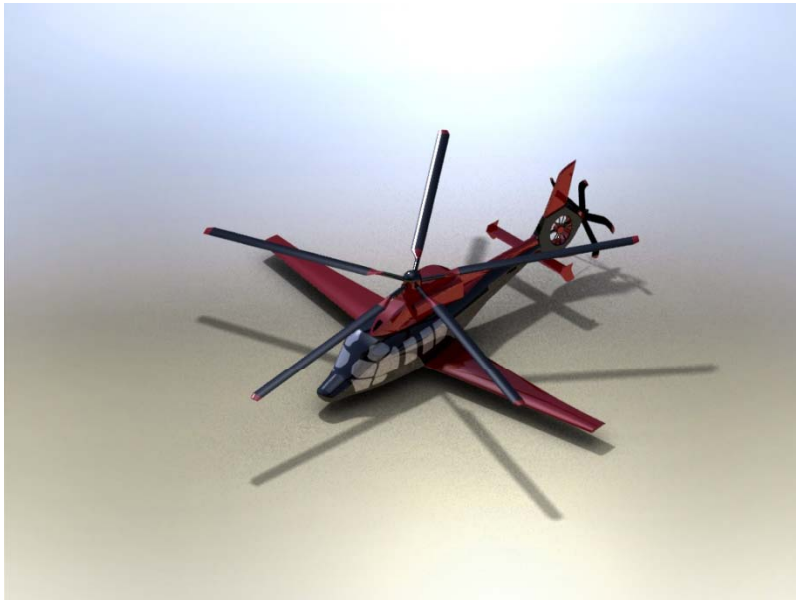

- Drag Components
  - Fuselage
  - Nacelle
  - Main Rotor
  - Horizontal Stabilizer
  - Vertical Stabilizer
  - Rotor-Fuselage Interference
  - Wing



# Comparison Between EC-155 and Pegasus

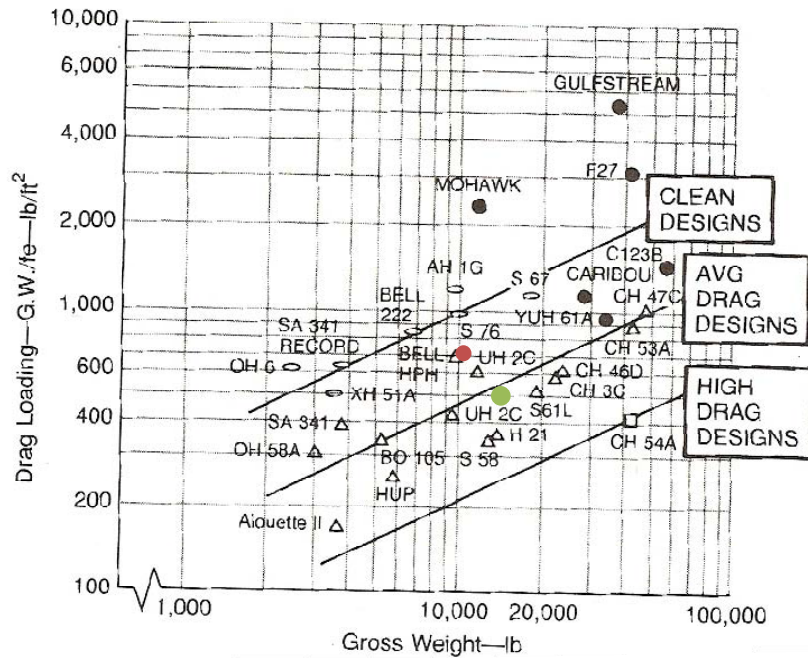

Component	EC 155	Pegasus
Fuselage	0.26	0.26
Nacelle	0.009	0.009
Main Rotor	0.998	1.326
Horizontal Stabilizer	0.030	0.049
Vertical Stabilizer	0.028	0.028
Rotor Fuselage Interference	0.072	0.072
Wing	0.00	0.671
<b>Total(m<sup>2</sup>)</b>	<b>1.397</b>	<b>2.414</b>
Gross Weight(lbs)	10824	13000
<u>Drag Loading(lb/ft<sup>2</sup>)</u>	719.806	505.637



# Weight Breakdown

Part	Advanced Technology Factor	Weight(kgf)	Percentage of Empty Weight
Airframe	0.92	562.454	19.0784
Drive System	0.9	302.455	10.259
Main Rotor Blades	0.96	286.806	9.728
Wing		258.21	8.758
Landing Gear	1	201.440	6.832
Electrical	1	189.646	6.432
Main Rotor Hub and Hinge	0.8	168.328	5.709
Furnishing	1	165.471	5.612
Anti-Torque Device	1	160	5.427
Auxiliary Propulsor		125	4.240
Propulsion Systems	0.9	82.010	2.781
Systems Controls	1	78.970	2.678
Auxiliary Power Plant	1	68.038	2.307
Avionics	1	68.038	2.307
Air Conditioning and Anti-Ice	1	47.173	1.601
Instruments	1	44.497	1.509
Hydraulics	1	42.592	1.444
Manufacturing Variation	1	23.586	0.800
Fuel System	1	23.0424	0.781
Nacelles	1	16.374	0.555
Cockpit Controls	1	14.560	0.493
Horizontal Stabilizer	0.7	11.611	0.393
Vertical Stabilizer	0.75	7.801	0.264
	<b>Total Pegasus Empty Weight</b>	<b>2948.111</b>	
	<b>Total EC-155 Empty Weight</b>	<b>2618</b>	



# Weight Breakdown

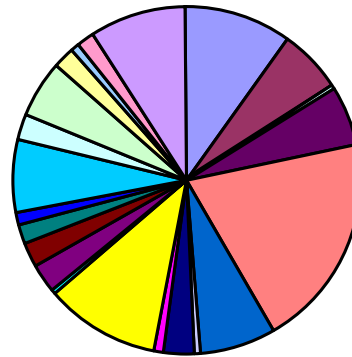

- |                         |                          |                       |                               |
|-------------------------|--------------------------|-----------------------|-------------------------------|
| Main Rotor Blades       | Main Rotor Hub and Hinge | Horizontal Stabilizer | Vertical Stabilizer           |
| Anti-Torque Device      | Airframe                 | Landing Gear          | Nacelles                      |
| Propulsion Systems      | Fuel System              | Drive System          | Cockpit Controls              |
| Systems Controls        | Auxiliary Power Plant    | Instruments           | Hydraulics                    |
| Electrical              | Avionics                 | Furnishing            | Air Conditioning and Anti-Ice |
| Manufacturing Variation | Auxiliary Propulsor      | Wing                  |                               |



# Center of Gravity Location

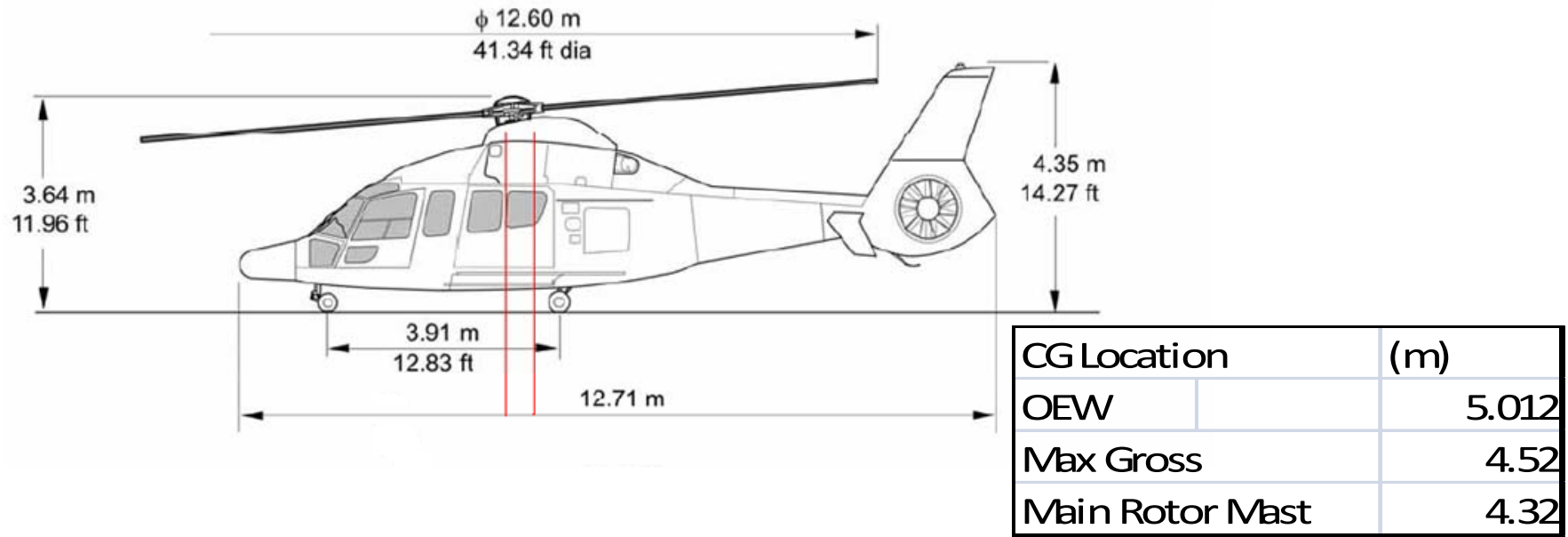

- Points measured relative to front of aircraft
- Space between lines is CG range from MTOW and OEW



# Pegasus vs. EC-155

