

# SOTERIA

36<sup>th</sup> Annual VFS Student Design Competition  
Extreme Altitude Mountain Rescue Vehicle  
Sponsored by **AIRBUS**



## EXECUTIVE SUMMARY

Center for Mobility with Vertical Lift (MOVE)  
Rensselaer Polytechnic Institute  
Troy, NY



# MOVE

Center for Mobility  
with Vertical Lift  
at Rensselaer

# *SOTERIA* Goddess of Safety

**Soteria**, a daughter of Zeus in Greek mythology, is considered the goddess of safety and salvation, deliverance, and preservation from harm. She represents sanctuary, a rescuer in the face of danger.



Following in this image, the Graduate Team from the Center for Mobility with Vertical Lift (MOVE) at Rensselaer, designed **Soteria**, a synchropter rescue helicopter, in response to the 36<sup>th</sup> Annual VFS Student Design Competition Request for Proposal sponsored by Airbus.

**Soteria** features two large intermeshing rotors, powered by dual turboshaft engines that enable the aircraft to climb and perform rescue missions at the Earth's highest point. The rear doors and winch mount allow for easy loading of victims from the mountain, while the state-of-the-art IFR avionics suite enables single pilot operation in the mountainous environment, freeing up the co-pilot to perform medical services



## MOVE

Center for Mobility  
with Vertical Lift  
at Rensselaer

# Extreme Altitude Mountain Rescue

High altitude flight has long been a challenge for VTOL aircraft, with extreme low density degrading rotor performance and reducing mass flow into the air-breathing engines, restricting operations at high altitude to only necessary rescue operations.

Climbing Mount Everest, the highest peak on Earth, has become more and more dangerous as the number of permits issued to attempt the summit has increased, crowding the mountain peak and stranding people in one of the harshest environments on the planet.

Typical rescue vehicles are unable to perform rescue operations at the peak (29,035 ft), but *Soteria* can hover and maneuver at this extreme condition (up to 32,000 ft), which gives hope to those who fall victim to the mountain environment.



## MOVE

Center for Mobility  
with Vertical Lift  
at Rensselaer

# Vehicle Configuration

- Capable of controlled hover at 8,870 m (29,100 ft)
- Minimum cruise speed of 259 km/h (140 kts)
- Capable of carrying 575 kg (1,268 lb)
- Requires excellent directional authority

## Possible Configurations: Existing Platforms



### *Soteria*

Lower disk loading for the same footprint

Excellent hover performance

No exposed tail rotor

Large power margin



# MOVE

Center for Mobility  
with Vertical Lift  
at Rensselaer

# SOTERIA

## Full Model - Skin Removed

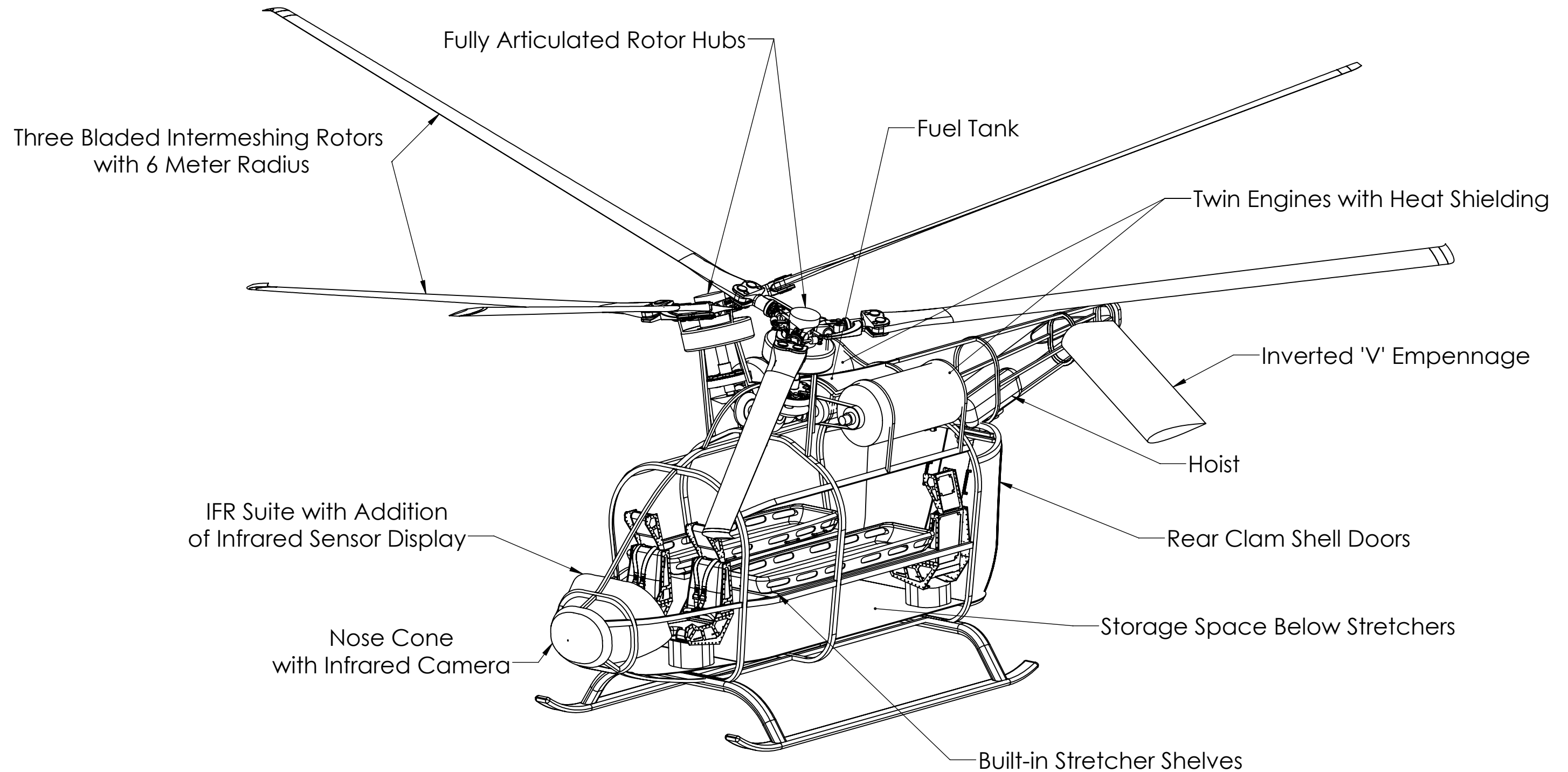

# Soteria

## Four View Drawing

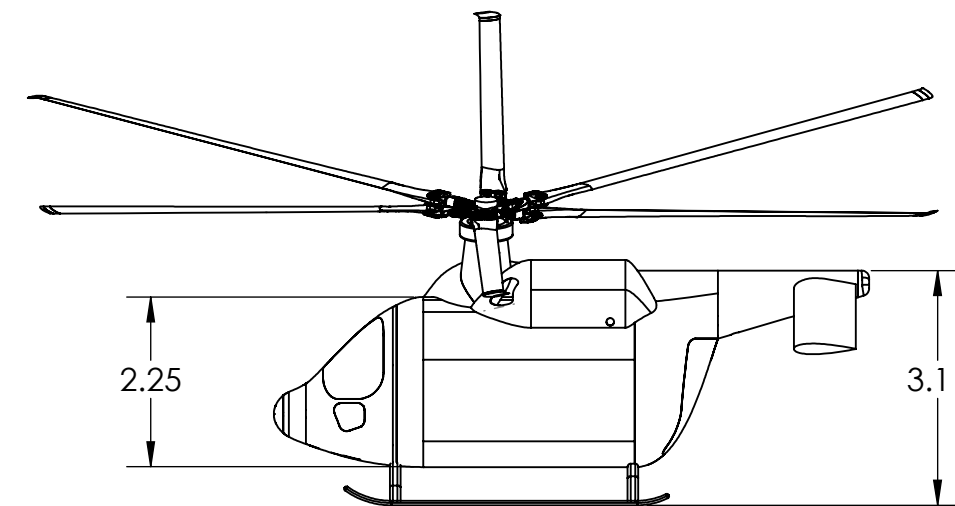
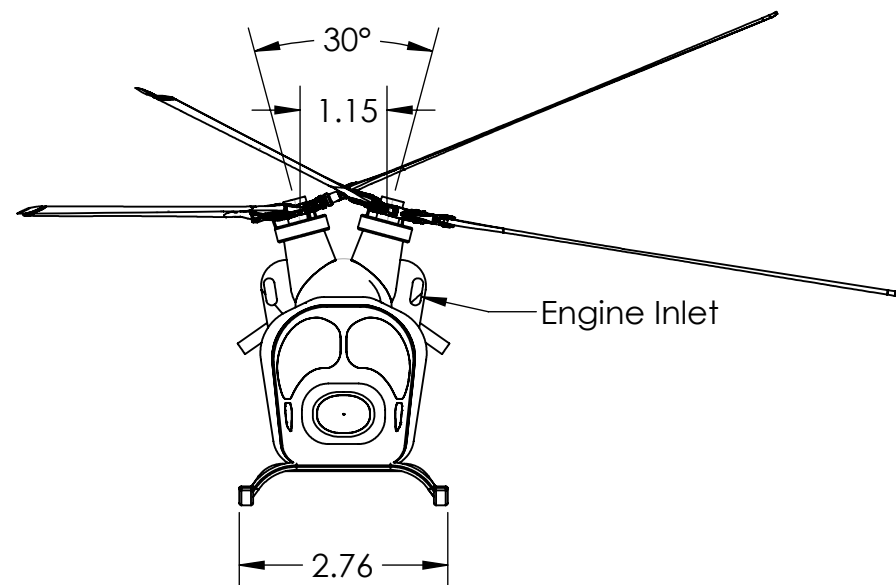
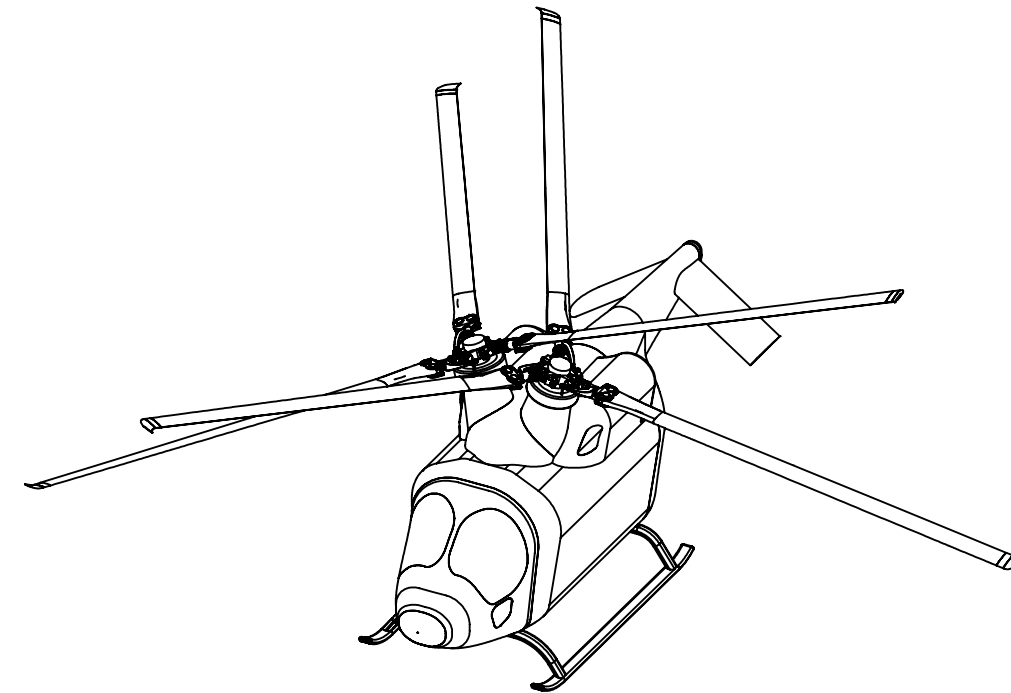
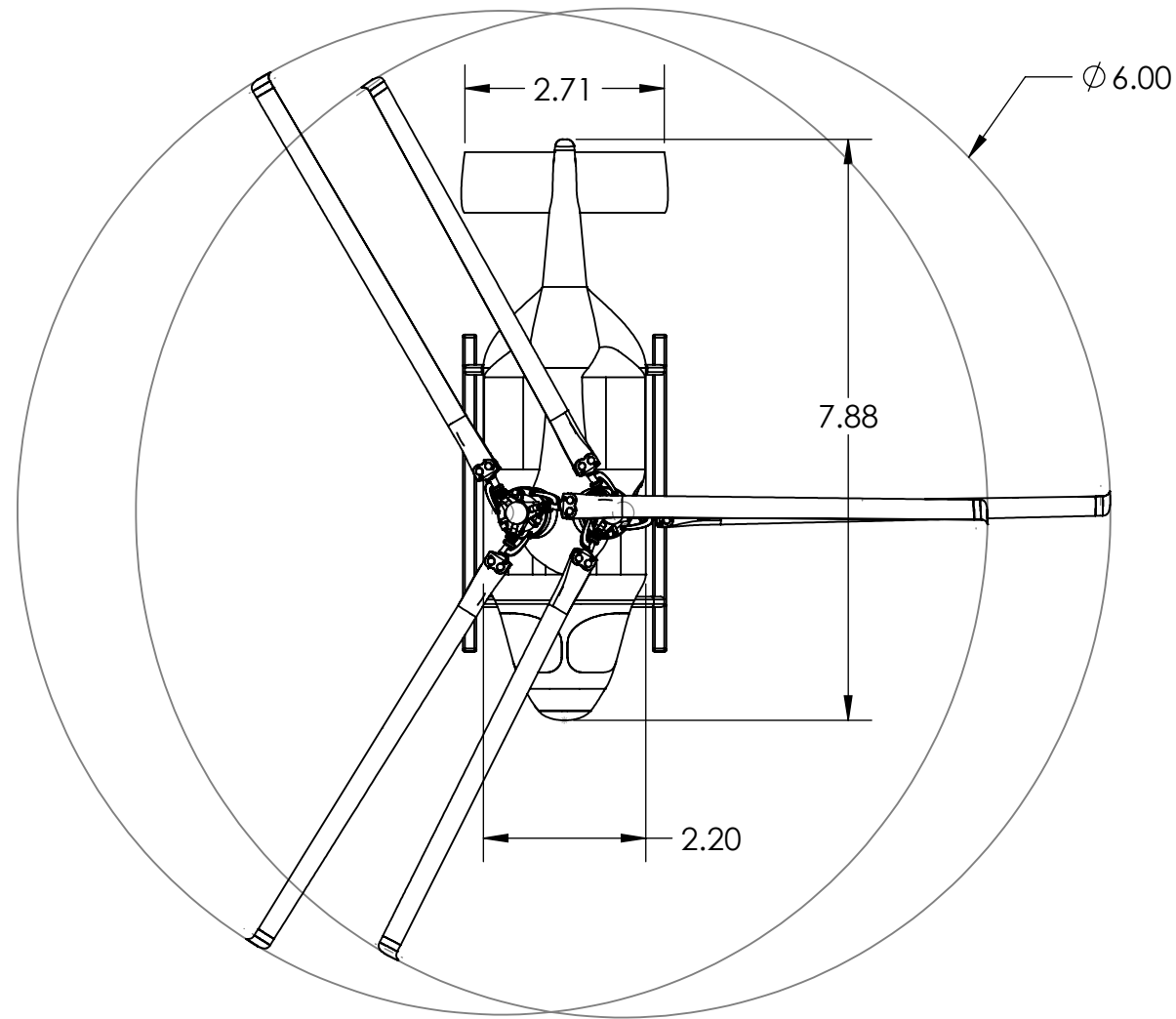

All Dimensions in Meters

# Rotor Design

Configuration identification identified single main rotor and synchropter as the two most viable candidates for design

Trade study comparing power consumption of the single vs dual rotor system performed to select final configuration

## Single vs Dual Rotor Design

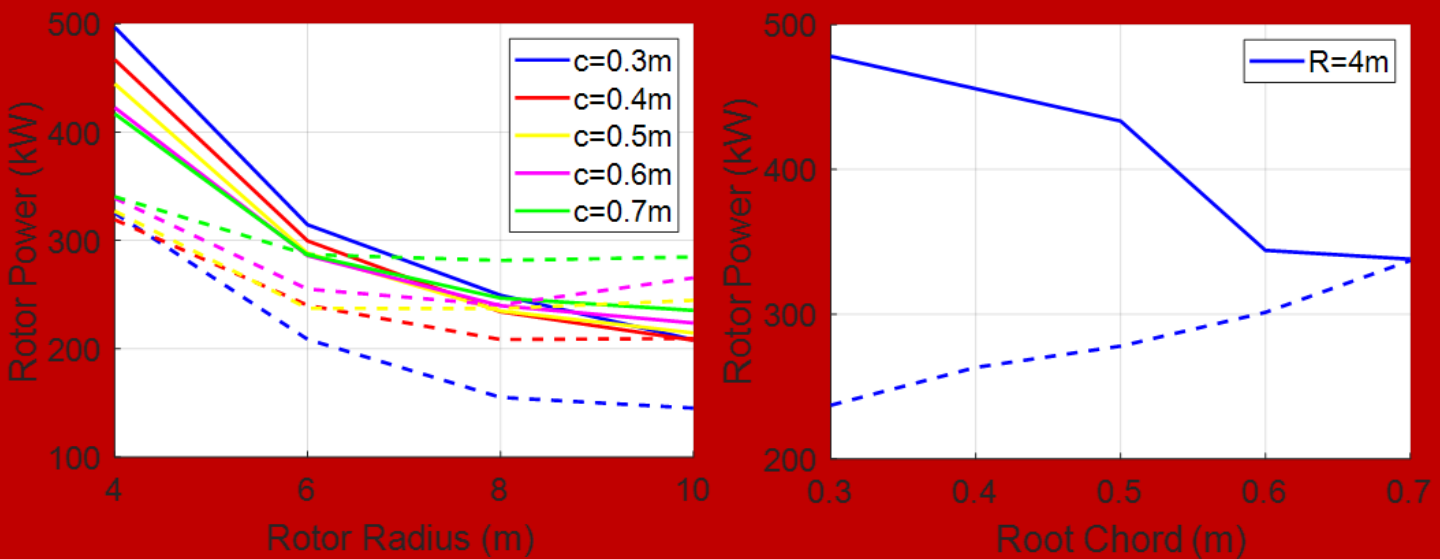

Dual Rotor system requires less power over most of the considered design space

Larger disk area reduces the disk loading at a nearly identical footprint to the single main rotor, reducing induced power and downwash (improves whiteout)

Dual rotor system is naturally torque balanced, obviating the need for a dedicated antitorque system, reducing power consumption and mechanical complexity



**MOVE**

Center for Mobility  
with Vertical Lift  
at Rensselaer

# Blade Aerodynamic Design

Hover at high altitude (low density) requires unique design choices for the rotor blades

$$dL = \frac{1}{2} \rho V^2 C_L(\alpha, M) c$$

To increase rotor thrust, increase dynamic pressure (increase  $\Omega$ ), increase sectional lift coefficient (increase  $\alpha$ , change airfoil), or increase chord length

Parametric study of rotor chord, twist, and airfoils conducted to determine best rotor design

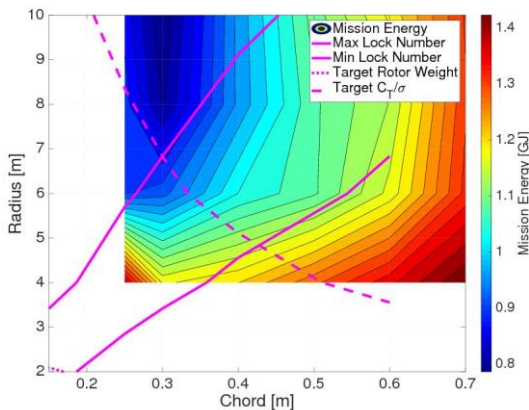
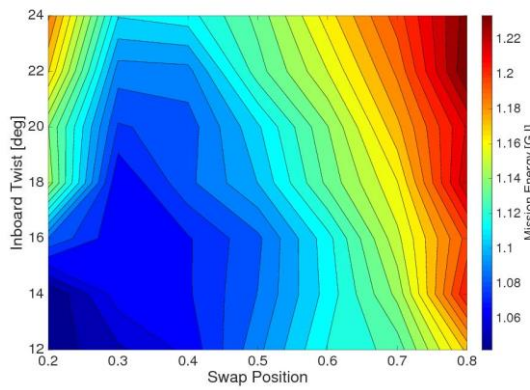
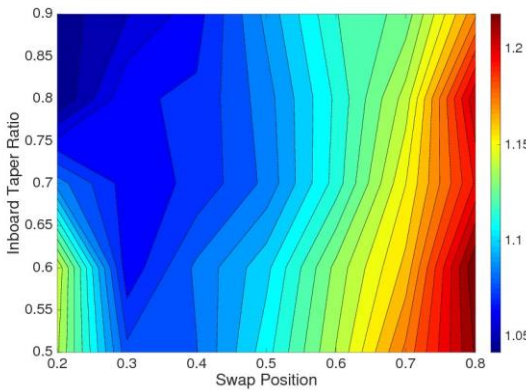

Radius	6 m
Root Chord	0.3 m
$N_b$	3
Twist Rate	$-20^\circ$ $r = 0.125 - 0.2$ $-12^\circ$ $r = 0.2 - 1$
Taper Ratio	0.9
Solidity ( $\sigma$ )	0.045

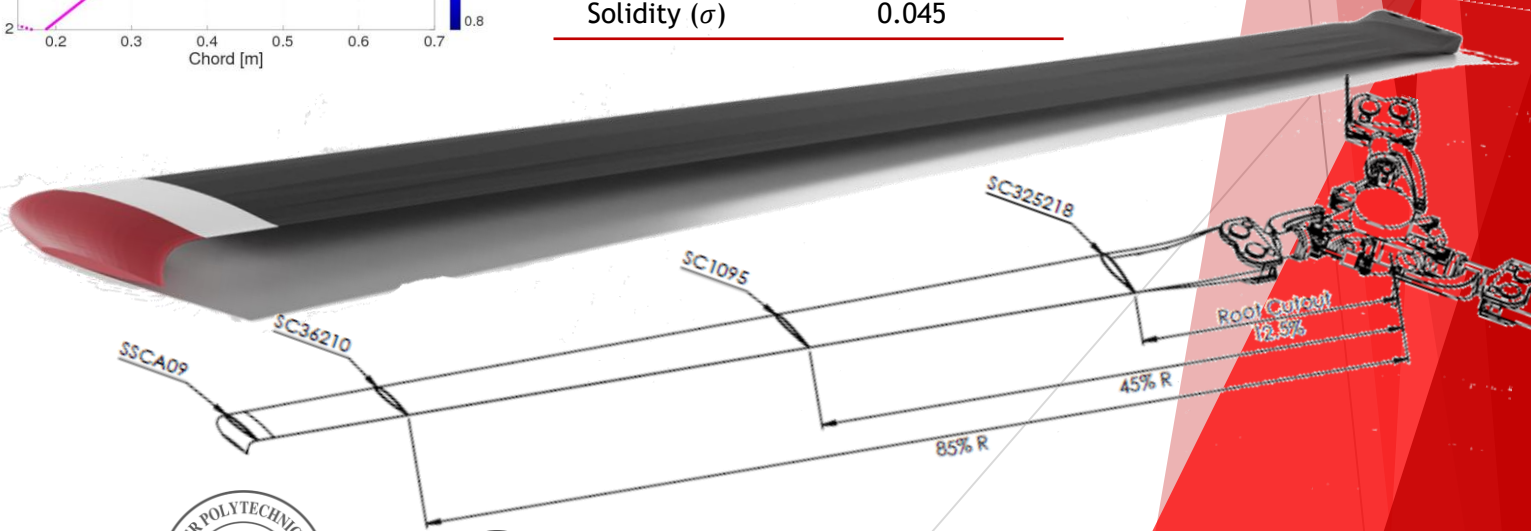

**MOVE**

Center for Mobility with Vertical Lift at Rensselaer

# Blade Structure Design

Blade constructed with a titanium alloy D-spar and an isotropic foam core covered by composite skin

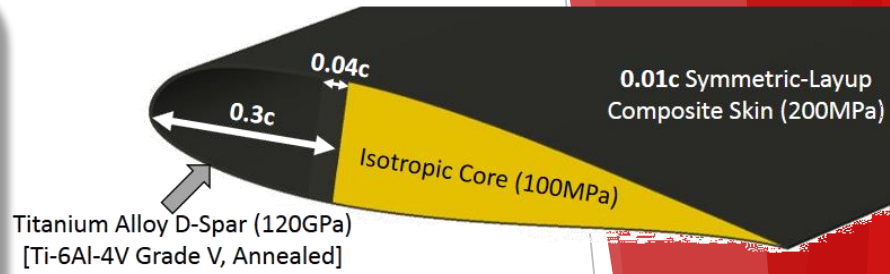

Peak RCAS predicted aerodynamic loading distributed along the blade model for finite element analysis

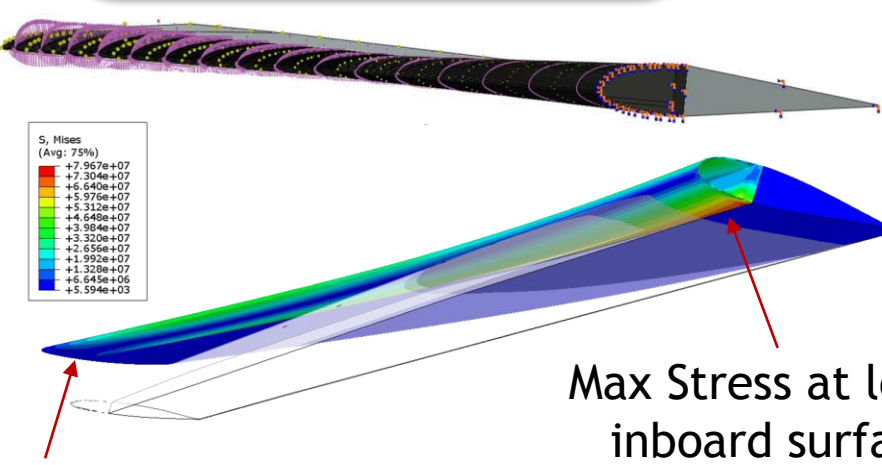

8.5 cm Elastic Tip Deflection

Per ABAQUS nonlinear finite element analysis, Ti-6Al-4V Grade V Annealed D-spar withstands peak hover aerodynamic and centrifugal loading with significant factor of safety, while matching the NDARC blade mass estimate

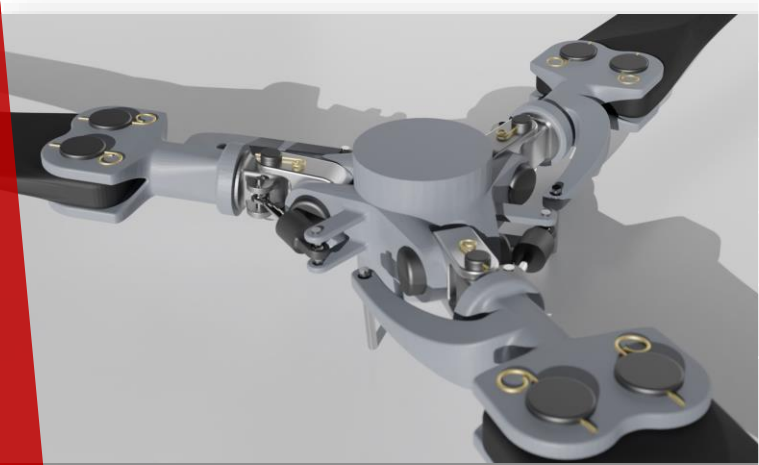

Rotor Parameters	
Blade Mass	33.6 kg (2.3 slug)
Hub Type	Fully Articulated
Blade Controls	Collective/Cyclic Pitch
Hub Separation	19% R
Post Separation Angle	30°



**MOVE**

Center for Mobility with Vertical Lift at Rensselaer

# Powerplant

Gas Turbine limitations at high altitude:

- **Decrease in operating pressure** requires more compressor work
- **Decrease in mass flow** reduces turbine work output

## Safran Arriel 2D

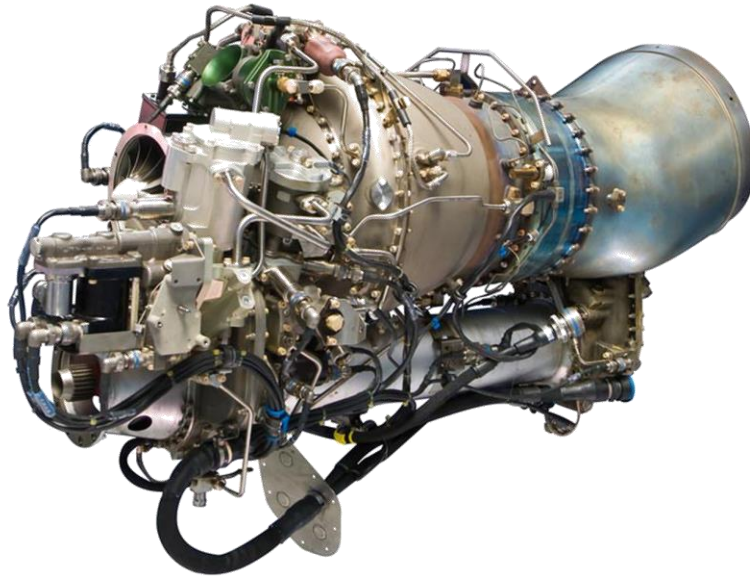

Specification	Sea Level	9000 m
Take Off Power	710 kW	300 kW
MCP	638 kW	216 kW
SFC	0.348 kg/kW-hr	0.331 kg/kW-hr

Dual turboshaft engines enable **redundancy** in the case of failure or flameout during operation. Power rating for each engine is sufficient to allow for **one engine inoperable** conditions while at the summit.



# MOVE

Center for Mobility  
with Vertical Lift  
at Rensselaer

# Transmission Design

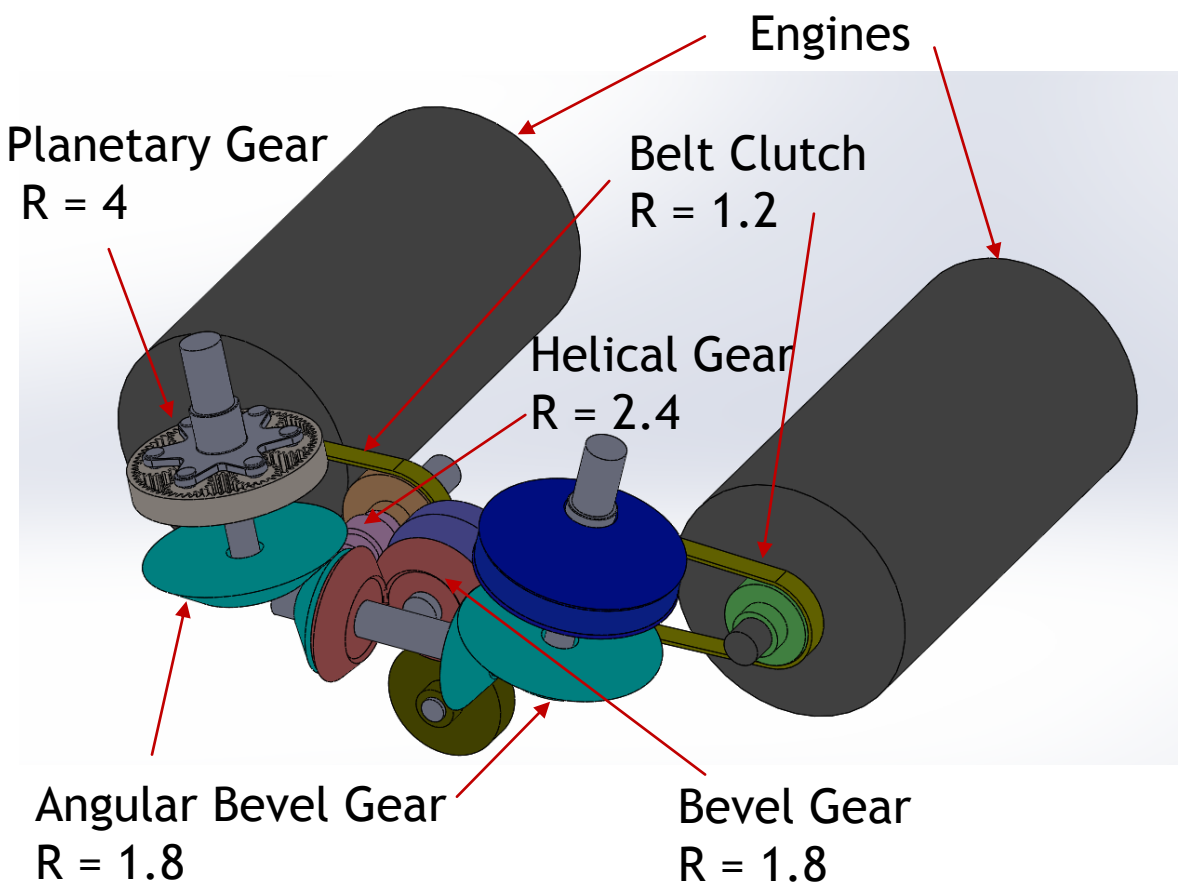

Transmission is geared to reduce the shaft speed of the engines (6000 RPM) to the main rotor speed (290 RPM)

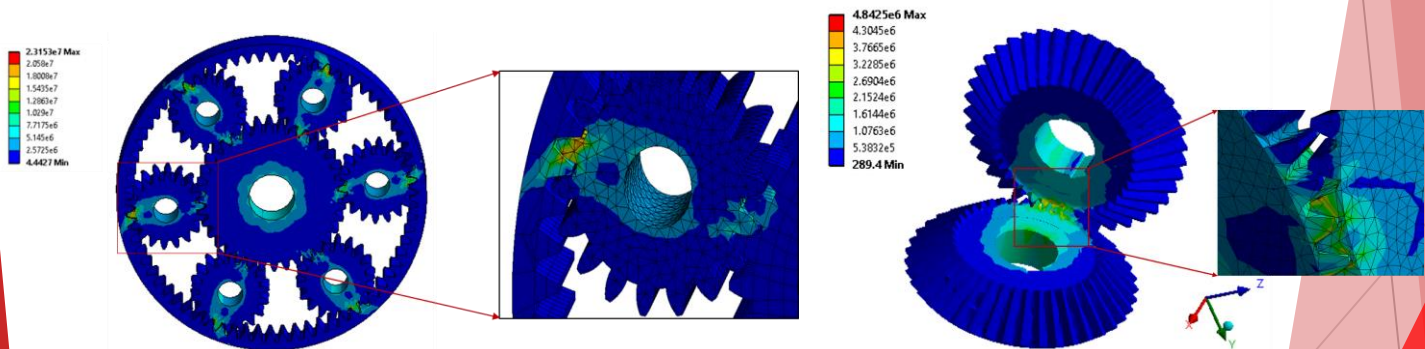

Finite element analysis performed in Abaqus to ensure drive train components never encounter yield stresses



**MOVE**

Center for Mobility  
with Vertical Lift  
at Rensselaer

# Soteria

## Structural Frame

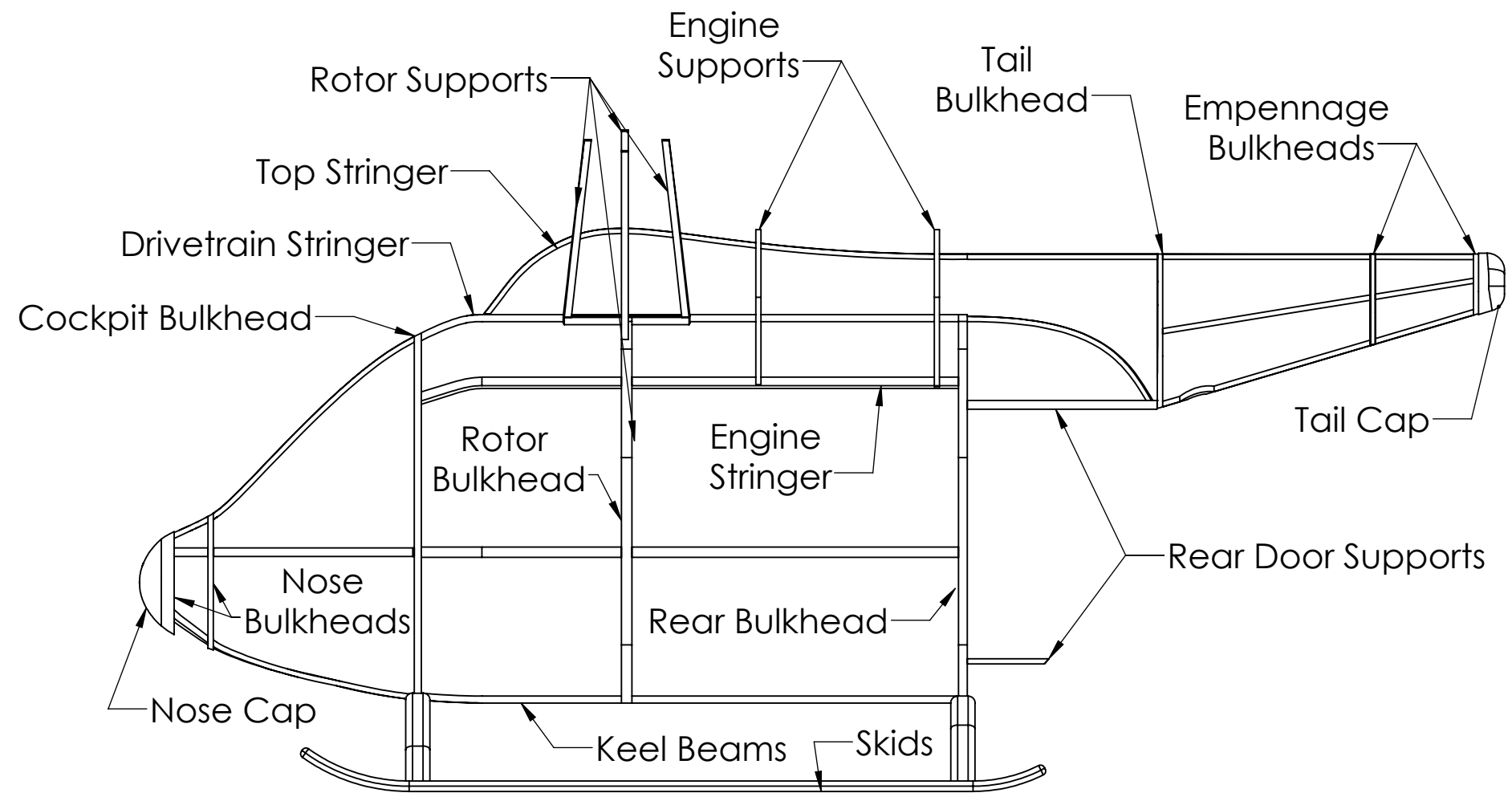
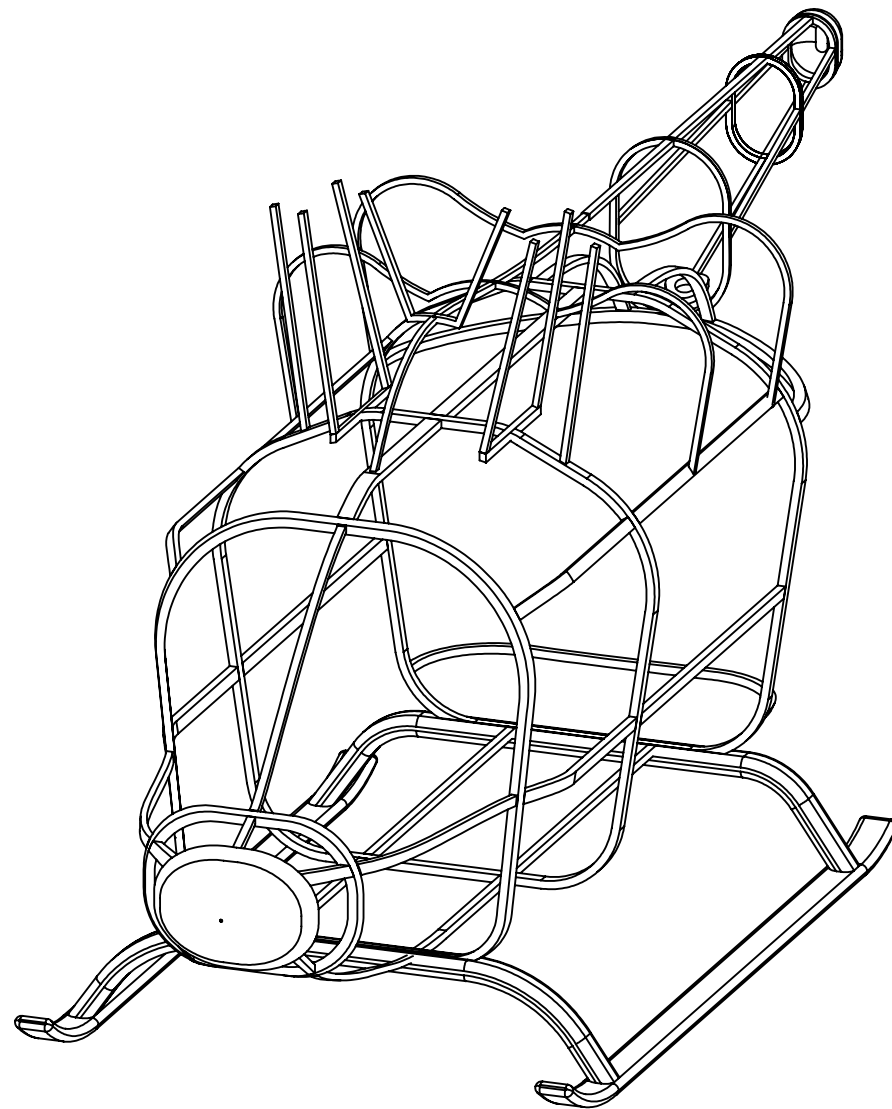

# Cabin Design

RFP: Soteria must carry 2 passengers, one dedicated medic, along with two crew members

The cabin is designed such that there is easy passage between the two patients laying on dedicated stretcher shelves, as well as between the cabin and cockpit for the copilot to assist with medical services

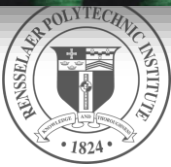
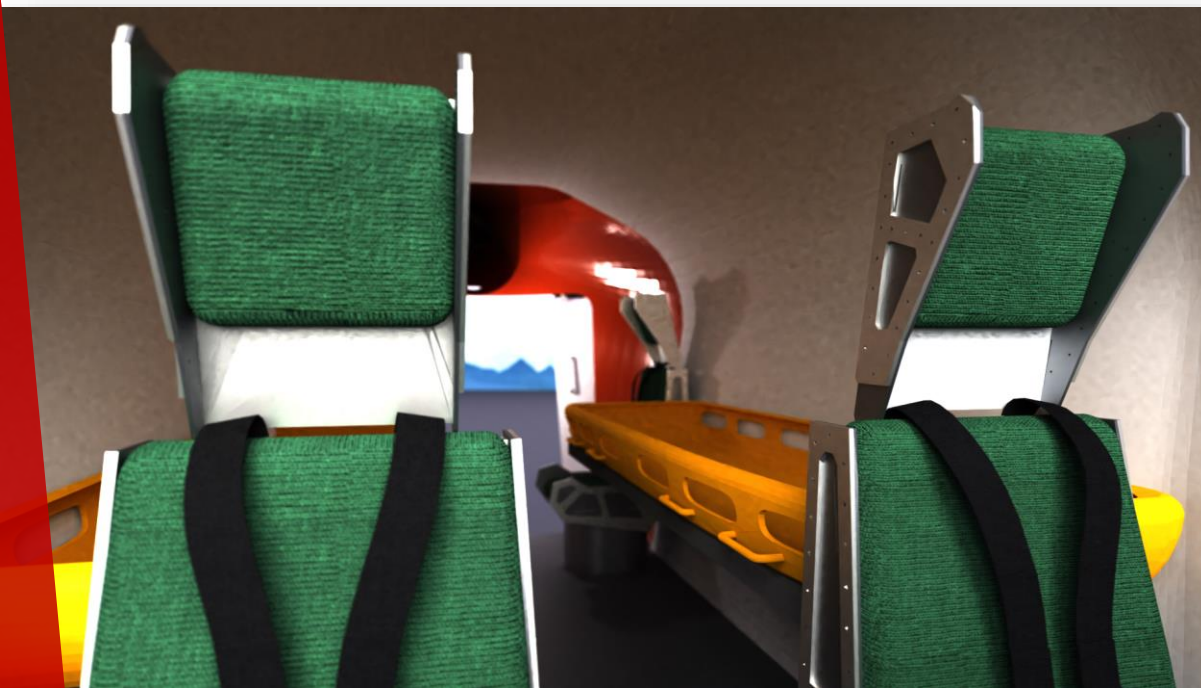
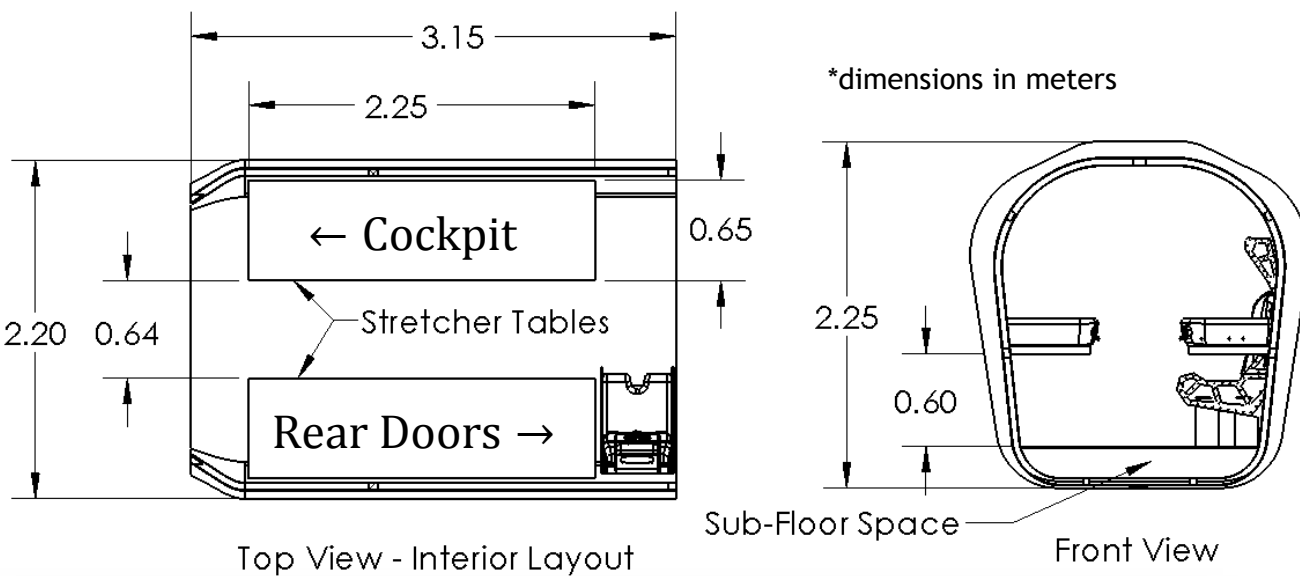

# MOVE

Center for Mobility  
with Vertical Lift  
at Rensselaer

# Passenger Loading



*Soteria*'s lack of a tail rotor allows for the loading of passengers at the rear of the vehicle. The tail boom structure provides shielding from the rotor downwash and a place to anchor the winch to allow victims to be raised all the way to cabin level from the ground, which expedites the loading and the entirety of the rescue operation. Mounting the hoist on the tail boom allows the load to be carried along the centerline of the aircraft, reducing the moment induced by the stretcher load.

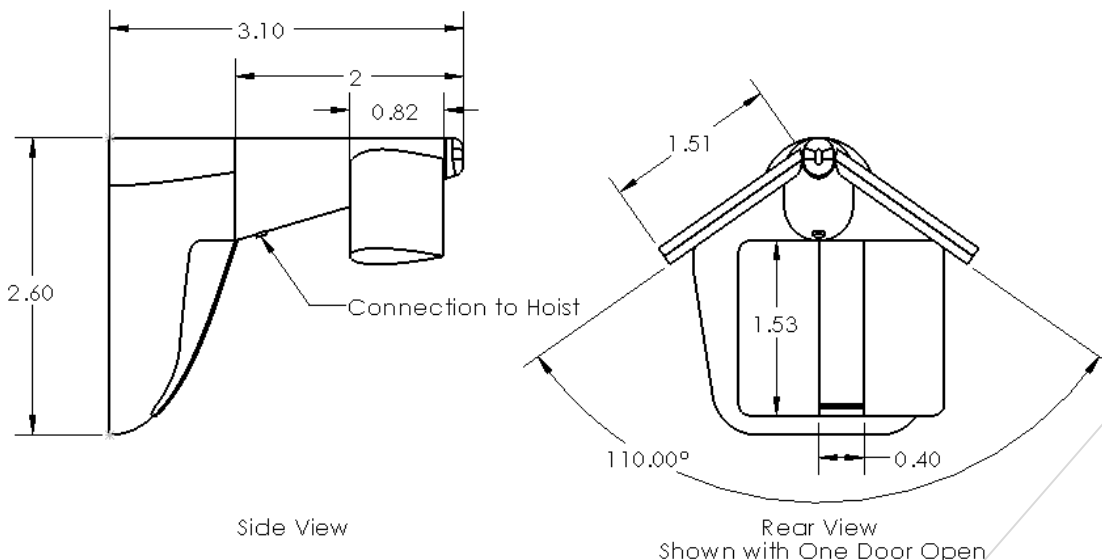

# MOVE

Center for Mobility  
with Vertical Lift  
at Rensselaer

# Flight Dynamics

Dynamic model of *Soteria* linearized in hover yields bare airframe dynamics:

Typical rigid body modes for a rotary wing vehicle indicates that standard control design will work well

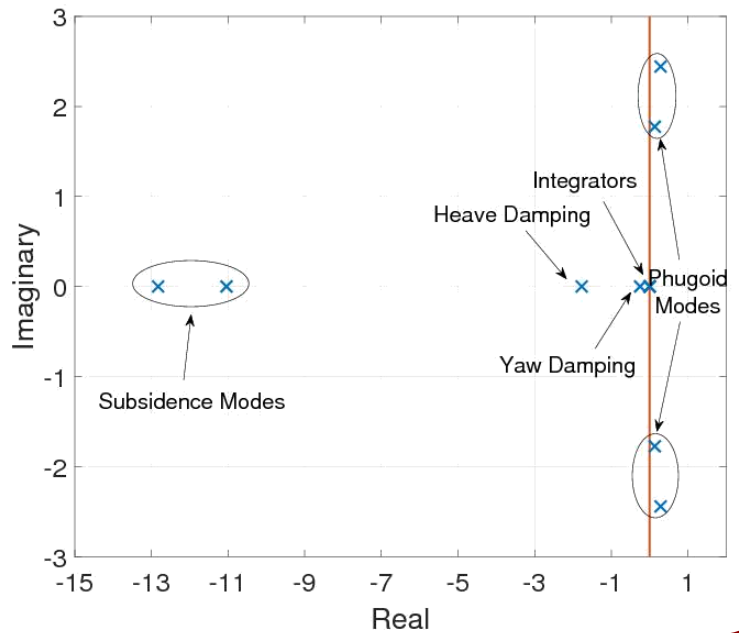

## Control System

### Model following Linear Dynamic Inversion

- ACAH Response type for inner loop control of  $\phi$  and  $\theta$
- RCAH Response type for inner loop heave control
- RCDH Response type for inner loop directional control
- TRCPH Response type for outer loop velocity control

LDI schedules the model with flight condition and reduces the aircraft dynamics, allowing for response characteristics to be tuned, this enables *Soteria* to satisfy handling qualities ratings through the flight envelope

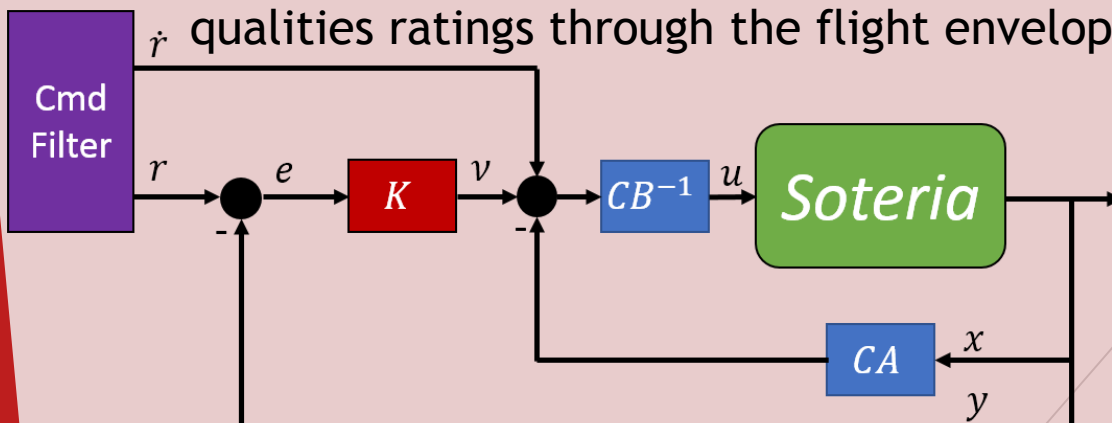

**MOVE**

Center for Mobility  
with Vertical Lift  
at Rensselaer

# Control Methodology

Dual rotor system on *Soteria* introduces 6 independent controls for the aircraft, allowing for flexibility in control mixer design for best performance

4 pilot stick inputs:  $\delta_0, \delta_{long}, \delta_{lat}, \delta_{ped}$  → 6 rotor controls:  $\theta_0, \Delta\theta_0, \theta_{1c}, \Delta\theta_{1c}, \theta_{1s}, \Delta\theta_{1s}$

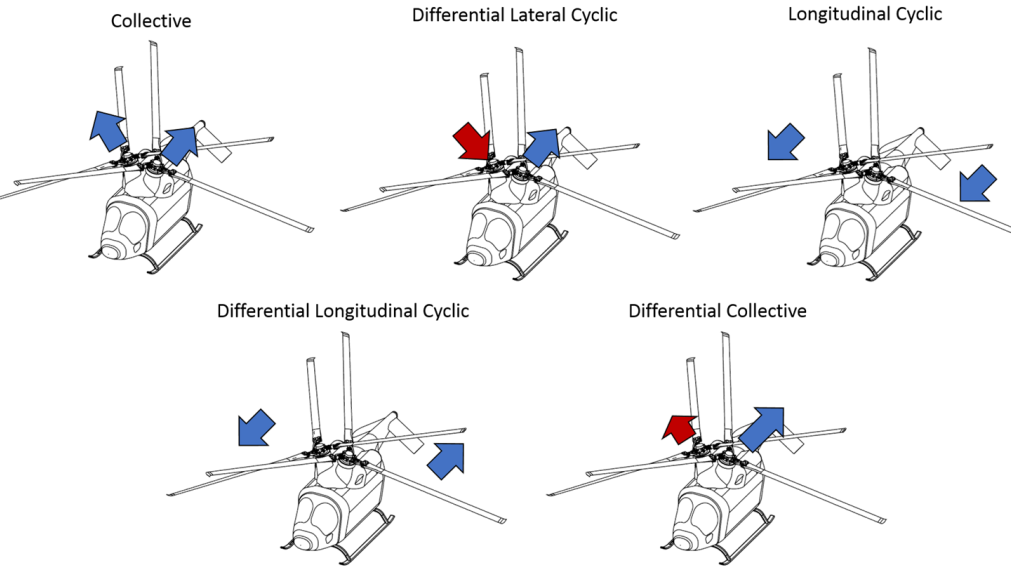

Stick Input	Rotor Control
$\delta_0$	$\theta_0$
$\delta_{long}$	$\theta_{1s}$
$\delta_{lat}$	$\Delta\theta_{1c}$
$\delta_{ped}$ (Low $\theta_0$ )	$\Delta\theta_{1s}$
$\delta_{ped}$ (High $\theta_0$ )	$\Delta\theta_0$

## Flight Deck Instrumentation

1/2	Pilot/Co-Pilot PFD
3/4	Pilot/Co-Pilot Navigation
5/6	Pilot/Co-Pilot GPS/NAV/COM
7	Transponder
8	Instrument Control
9/10	Pilot/Co-Pilot Audio Comm Control
11	Autopilot Control
12	IR Camera Display



# MOVE

Center for Mobility  
with Vertical Lift  
at Rensselaer

# Safety in Rescue

*Soteria* is designed with the safety of the passengers and crew in mind

Lack of an exposed tail rotor reduces risk of harm to ground operators as well as loss of directional control from blade strike or power loss



Large rear loading doors and tail mounted winch allows easy onboarding of victims, ample working space, and shielding from the rotor downwash



Full IFR avionics suite enables single pilot operation in instrument meteorological conditions, freeing up the copilot to provide medical assistance



Large dual rotor system reduces aircraft disk loading, which reduces the rotor induced velocity and mitigates white out conditions during operations



Dual gas turbines provide sufficient power margin for hover in one engine inoperable conditions at the peak, as well as maneuvering power for gusts and turbulence

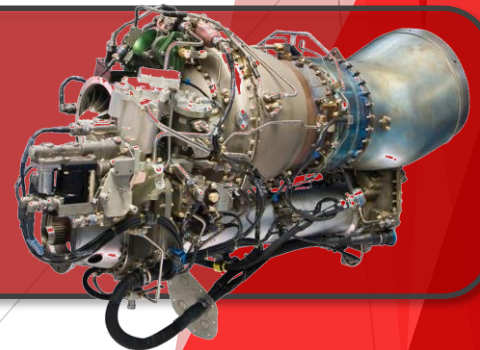

## MOVE

Center for Mobility  
with Vertical Lift  
at Rensselaer

# Soteria Performance

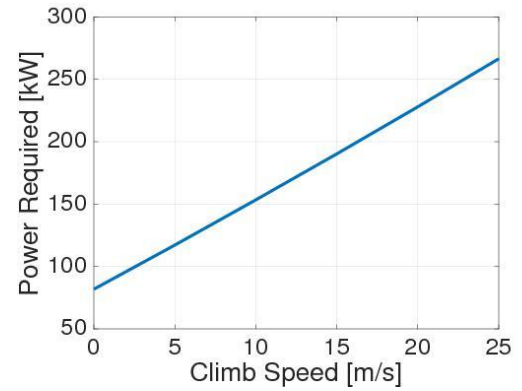
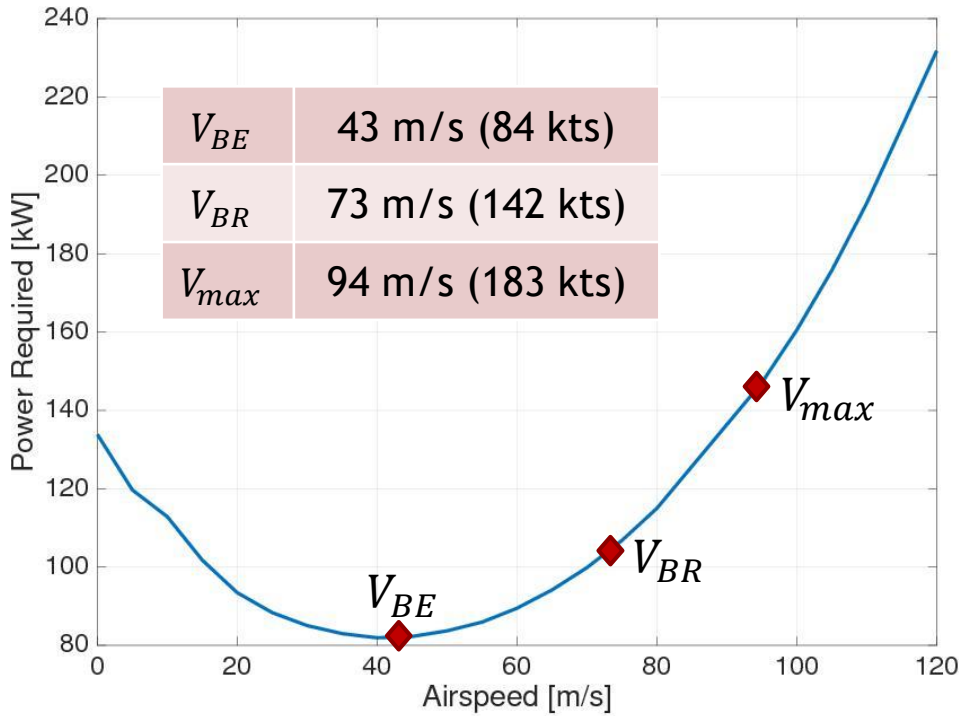

Climb and Descent power at 3,780 m (12,400 ft) at 43 m/s (84kts)

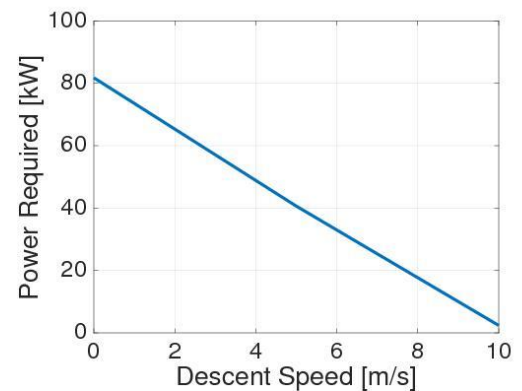

Cruise speed trim sweep at 3,780 m (12,400 ft)

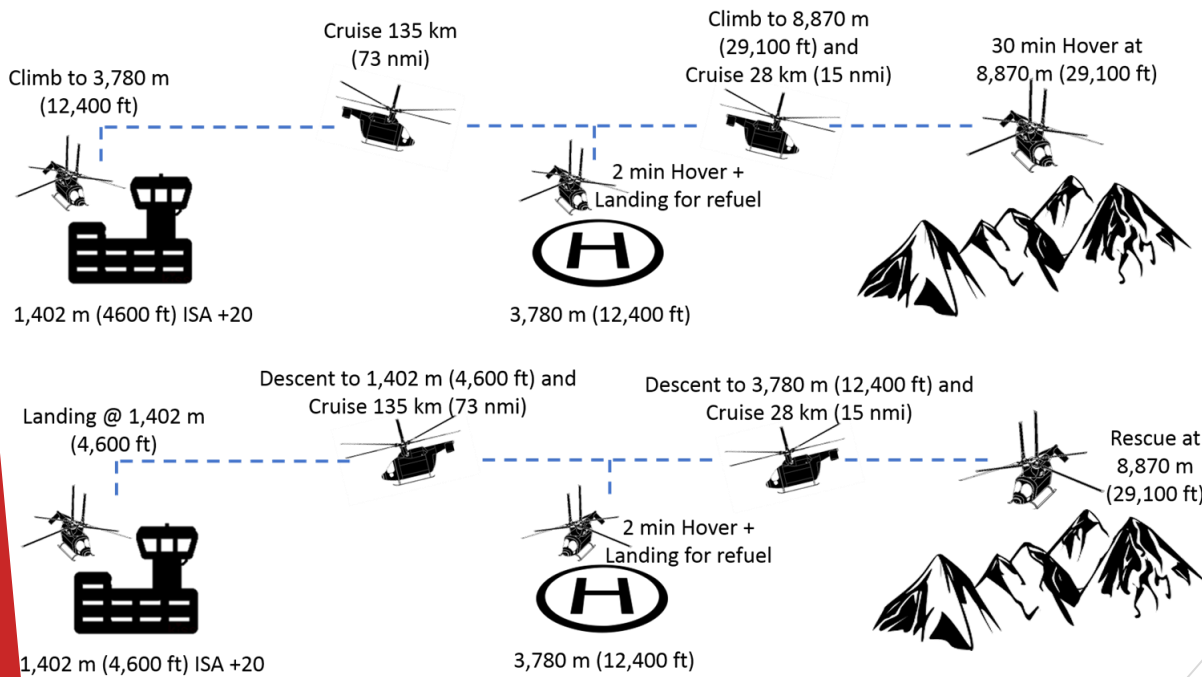

## Mission Performance

Maximum Power:  
Hover at Summit  
(160 kW, 215 HP)

Total Mission  
Energy: 0.8 GJ

Total Fuel Weight:  
82 kg



# MOVE

Center for Mobility  
with Vertical Lift  
at Rensselaer

# Summary

**Soteria** is a synchropter platform designed specifically for extreme altitude mountain rescue enabled by specific design choices

Large intermeshing rotor system improves disk loading for the same footprint and improves power consumption in hover relative to a single main rotor vehicle

Dual turboshaft engines provide sufficient power for hover up to 9,800 m (32,000 ft) and OEI capability at the summit

Rear loading door, tail mounted winch, and large interior cabin enable easy loading and treatment of victims onboard

Full IFR avionics suite sufficient for single pilot operation in IMC allows for copilot to administer medical attention if required

Acquisition Cost	\$3.13 M
Annual Operation	\$581K
Annual Flight Hours	210 hr



# MOVE

Center for Mobility  
with Vertical Lift  
at Rensselaer